

twin cylinder engine

# SERVICE MANUAL

# MAGNUM

MODELS MV16, MV18, MV20

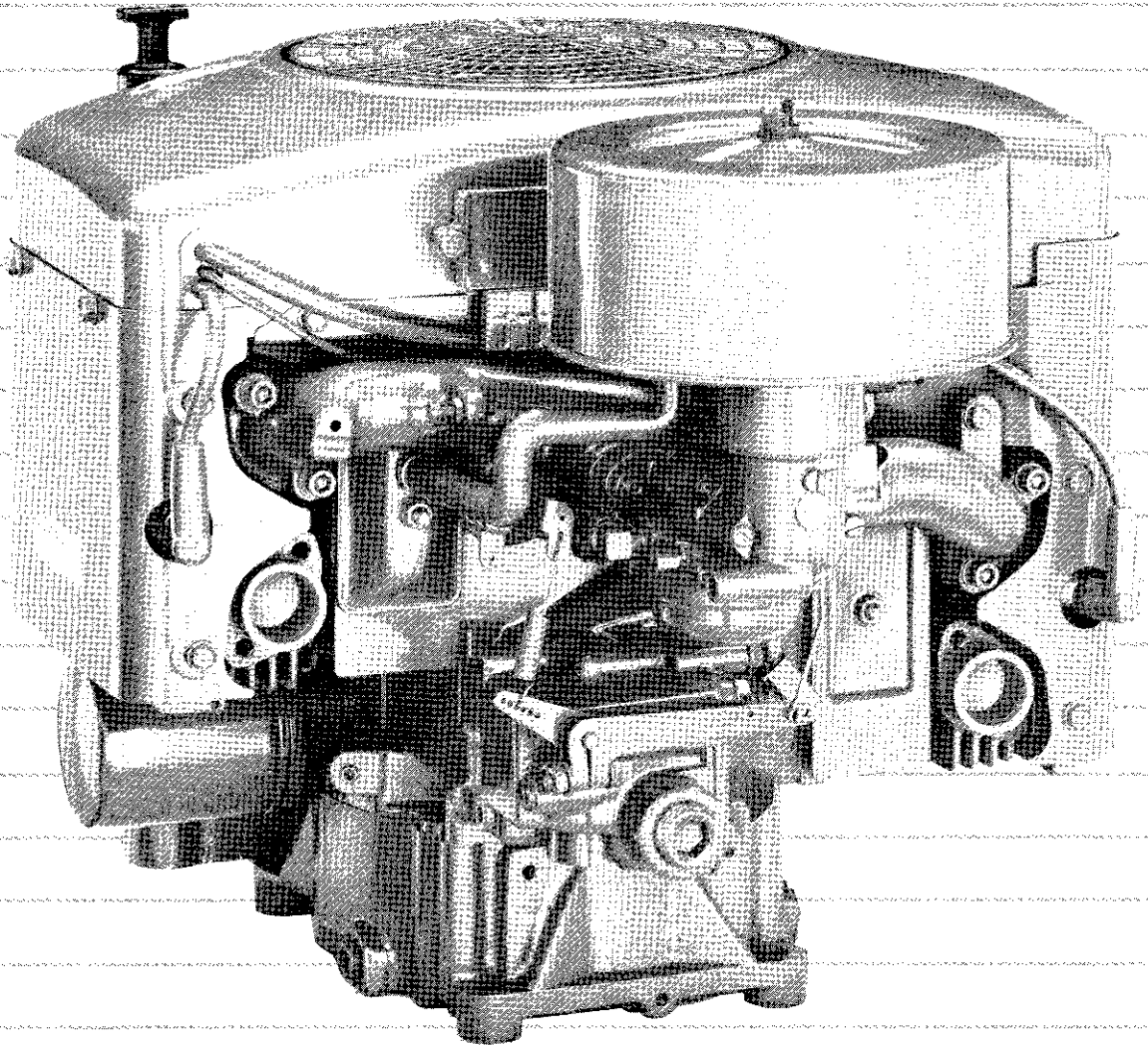

**KOHLER**  
engines

# CONTENTS

---

<b>SECTION 1. General Information .....</b>	<b>1</b>
<b>SECTION 2. Special Tools .....</b>	<b>2</b>
<b>SECTION 3. Periodic Maintenance .....</b>	<b>3</b>
<b>SECTION 4. Troubleshooting .....</b>	<b>4</b>
<b>SECTION 5. Air Cleaner .....</b>	<b>5</b>
<b>SECTION 6 Fuel System And Governor .....</b>	<b>6</b>
<b>SECTION 7. Lubrication System .....</b>	<b>7</b>
<b>SECTION 8. Electrical System And Components .....</b>	<b>8</b>
<b>SECTION 9. Disassembly .....</b>	<b>9</b>
<b>SECTION 10. Inspection And Repair/Reconditioning .....</b>	<b>10</b>
<b>SECTION 11. Reassembly .....</b>	<b>11</b>

---

# SECTION 1 GENERAL INFORMATION

## ENGINE IDENTIFICATION NUMBERS

When ordering parts, or in any communication involving an engine, always give the Model, Specification, and Serial numbers of the engine.

The engine identification numbers appear on a decal (or decals) affixed to the engine shrouding. Refer to Figure 1-1. The significance of these numbers is shown below:

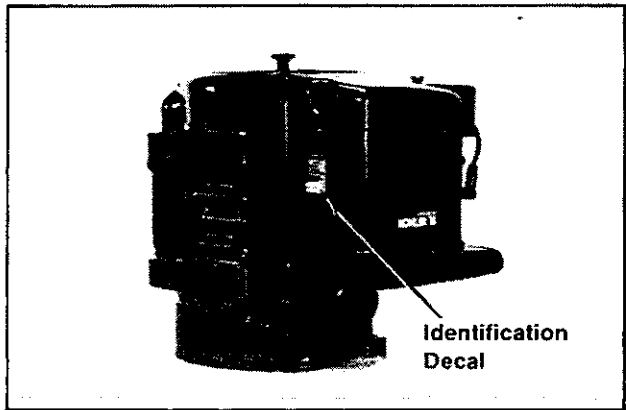

Figure 1-1. Location Of Engine Identification Decal.

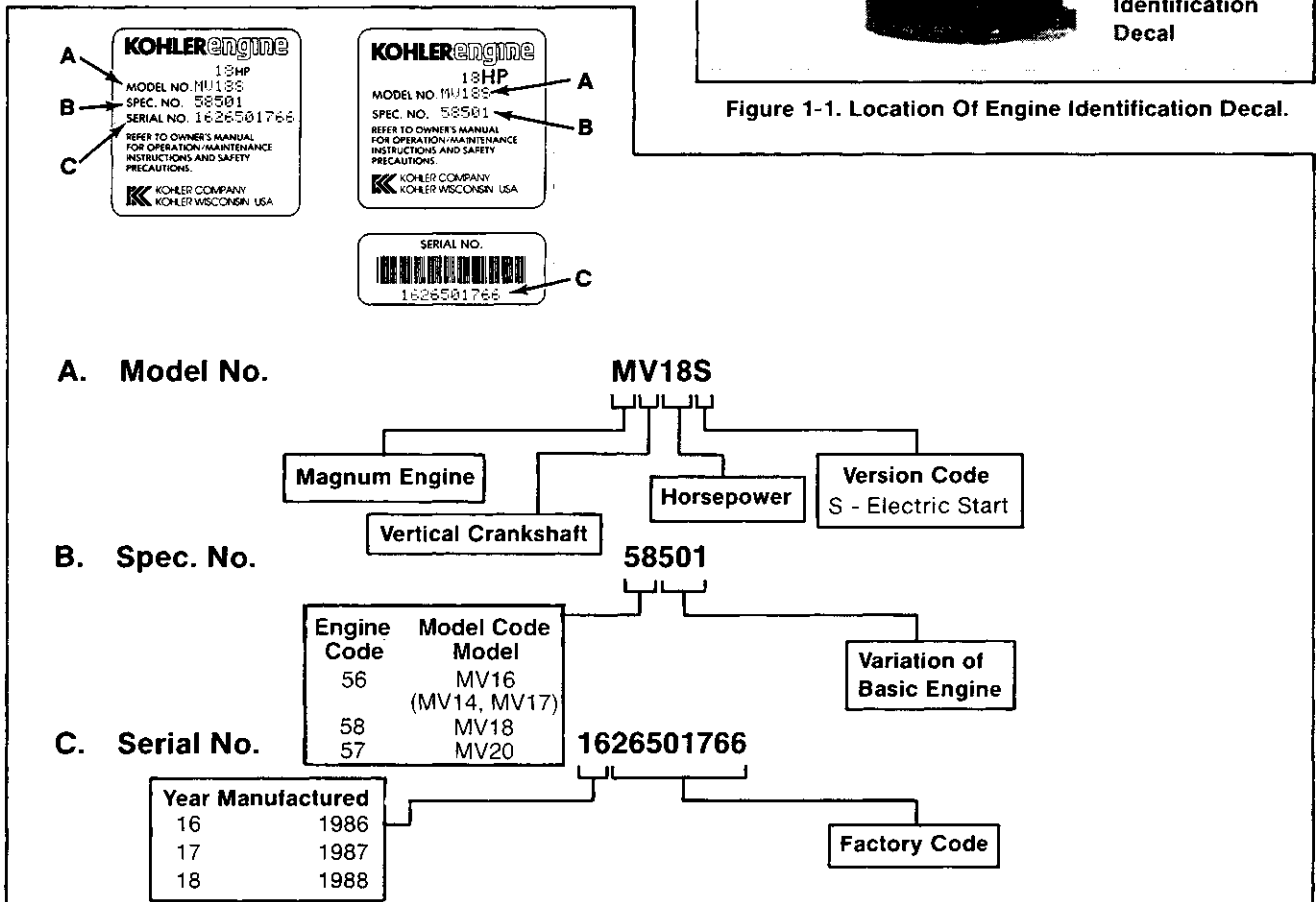

Figure 1-2. Engine Identification Decals.

---

## FOR YOUR SAFETY

### WARNING: For Your Safety!



*This symbol points out important safety Warnings and Cautions throughout this manual. These Warnings and Cautions should be followed at all times. Failure to follow Warnings and Cautions could result in injury to yourself and others nearby.*

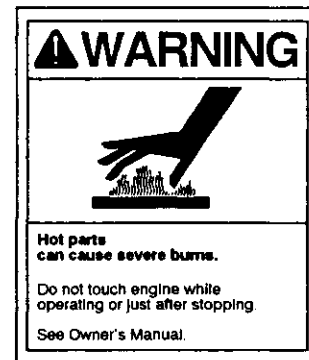
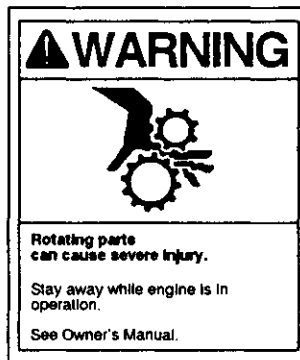
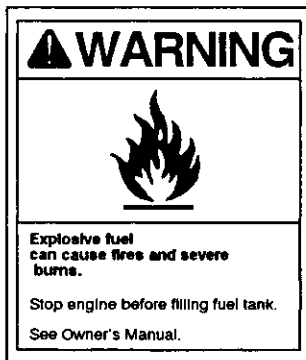

### WARNING: Explosive Fuel!



*Gasoline is extremely flammable and its vapors can explode if ignited. Store gasoline only in approved containers, in well-ventilated, unoccupied buildings, away from sparks or flames. Do not fill the fuel tank while the engine is hot or running, since spilled fuel could ignite if it comes in contact with hot parts or sparks from ignition. Do not start the engine near spilled fuel. Never use gasoline as a cleaning agent.*

### WARNING: Rotating Parts!



*Keep hands, feet, hair, and clothing away from all moving parts to prevent injury. Never operate the engine with covers, shrouds, or guards removed.*

### WARNING: Hot Parts!



*Engine components can get extremely hot from operation. To prevent severe burns, do not touch these areas while the engine is running—or immediately after it is turned off. Never operate the engine with heat shields or guards removed.*

**WARNING: Accidental Starts!**



*Before servicing the engine or equipment, always disconnect the spark plug lead to prevent the engine from starting accidentally. Ground the lead to prevent sparks that could cause fires. Make sure the equipment is in neutral.*

**WARNING: Dangerous Acid, Explosive Gases!**



*Batteries contain sulfuric acid. To prevent acid burns, avoid contact with skin, eyes, and clothing. Batteries produce explosive hydrogen gas while being charged. To prevent a fire or explosion, charge batteries only in well ventilated areas. Keep sparks, open flames, and other sources of ignition away from the battery at all times. Keep batteries out of the reach of children. Remove all jewelry when servicing batteries.*

**WARNING: Flammable Solvents!**



*Carburetor cleaners and solvents are extremely flammable. Keep sparks, flames, and other sources of ignition away from the area. Follow the cleaner manufacturer's warnings and instructions on its proper and safe use. Never use gasoline as a cleaning agent.*

**CAUTION: Electrical Shock!**



*Never touch electrical wires or components while the engine is running. They can be sources of electrical shock.*

**WARNING: Spring Under Tension!**



*Retractable starters contain a powerful, flat wire recoil spring that is under tension. Do not remove the center screw from the starter until the spring tension is released. Removing the center screw before releasing spring tension, or improper starter disassembly, can cause the sudden and potentially dangerous release of the spring.*

**WARNING: Lethal Exhaust Gases!**



*Engine exhaust gases contain poisonous carbon monoxide. Carbon monoxide is odorless, colorless, and can cause death if inhaled. Avoid inhaling exhaust fumes, and never run the engine in a closed building or confined area.*

*Before disconnecting the negative (-) ground cable, make sure all switches are OFF. If ON, a spark will occur at the ground cable terminal which could cause an explosion if hydrogen gas or gasoline vapors are present.*

*Always wear safety goggles when servicing retractable starters—full face protection is recommended.*

**WARNING: Overspeed Is Hazardous!**



*Do not tamper with the governor setting. Overspeed is hazardous and could cause personal injury.*

*To ensure personal safety and proper starter disassembly and reassembly, follow the procedures in this section carefully.*

## OIL RECOMMENDATIONS

Using the proper type and weight of oil in the engine crankcase and in the gear reduction unit is extremely important, as is checking oil daily and changing oil regularly. Failure to use the correct oil or using dirty oil causes premature engine wear and failure.

### Oil Type

Use high-quality detergent oil of API (American Petroleum Institute) Service Class SF or SG. Select the viscosity based on the air temperature at the time of operation as shown in the table.

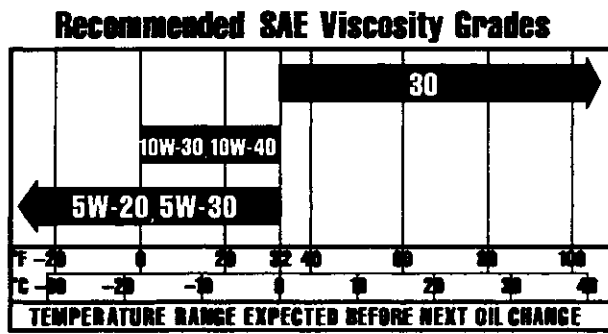

Straight 30-weight oil is preferred. SAE 10W-30 and 10W-40 are not recommended above 32°F (0°C). Using these oils substantially increases oil consumption and combustion chamber deposits.

**NOTE:** Using other than Service Class SF or SG oil or extending oil change intervals longer than recommended could cause engine damage which is not covered by the engine warranty.

A logo or symbol on oil containers identifies the API service class and SAE viscosity grade. Refer to Figure 1-3.



Figure 1-3. Oil Container Logo.

### Check Oil Level

Check oil level BEFORE EACH USE.

**CAUTION:** Do not operate the engine with the oil level below the "L" mark or over the "F" mark on dipstick. Refer to Figure 1-4.

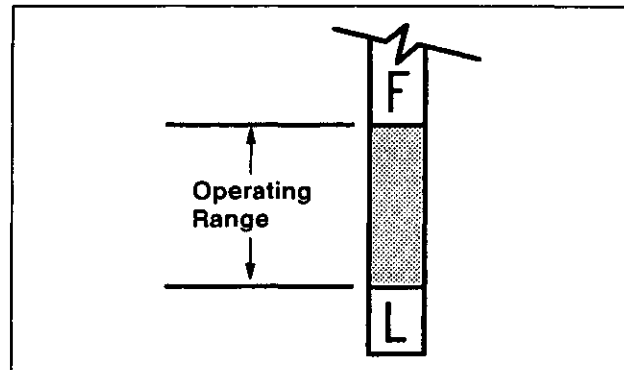

Figure 1-4. Oil Level Operating Range.

### Change Oil

**For a new engine,** change oil after the first 5 hours of operation. Thereafter, change the oil as specified in the following "Oil Change Intervals" table.

For an overhauled engine or those rebuilt with a new shortblock, use straight 30-weight Service Class SF or SG for the first 5 hours of operation. Change the oil after this initial run-in period. Refill with Service Class SF or SG as specified in the table.

#### OIL CHANGE INTERVALS

Temperature	Oil Type	Engine Type	Interval
<b>ABOVE 32°F (0°C)</b>	SAE 30	With Filter	50 Hours*
		Without Filter	25 Hours
	Multiviscosity	With Filter	25 Hours
		Without Filter	25 Hours
<b>BELOW 32°F (0°C)</b>	Multiviscosity	With Filter	50 Hours
		Without Filter	25 Hours

\*25 hours for continuous and/or heavy duty operation.

### Oil Filter

Some engines are equipped with an oil filter. Replace the oil filter every other oil change, in accordance with the "Oil Change Intervals" table. Always use a genuine Kohler replacement oil filter.

Refer to the "Periodic Maintenance" section for detailed oil checking and changing procedures.

Do not use gasoline left over from the previous season, to minimize gum deposits in your fuel system and to insure easy starting.

Do not add oil to the gasoline.

Do not overfill the fuel tank. Leave room for the fuel to expand.

### FUEL RECOMMENDATIONS

**WARNING: Explosive Fuel!**



*Gasoline is extremely flammable and its vapors can explode if ignited. Store gasoline only in approved containers, in well-ventilated, unoccupied buildings, away from sparks or flames. Do not fill the fuel tank while the engine is hot or running, since spilled fuel could ignite if it comes in contact with hot parts or sparks from ignition. Do not start the engine near spilled fuel. Never use gasoline as a cleaning agent.*

### Fuel Type

For best results, use only clean, fresh, unleaded gasoline with a pump sticker octane rating of 87 or higher. In countries using the Research method, it should be 90 octane minimum.

Unleaded gasoline is recommended, as it leaves less combustion chamber deposits. Leaded gasoline may be used in areas where unleaded is not available and exhaust emissions are not regulated. Be aware however, that the cylinder head will require more frequent service.

### Gasoline/Alcohol blends

Gasohol (up to 10% ethyl alcohol, 90% unleaded gasoline by volume) is approved as a fuel for Kohler engines. Other gasoline/alcohol blends are not approved.

### Gasoline/Ether blends

Methyl Tertiary Butyl Ether (MTBE) and unleaded gasoline blends (up to a maximum of 15% MTBE by volume) are approved as a fuel for Kohler engines. Other gasoline/ether blends are not approved.

### General Recommendations

Purchase gasoline in small quantities and store in clean, approved containers. A container with a capacity of 2 gallons or less with a pouring spout is recommended. Such a container is easier to handle and helps eliminate spillage during refueling.

### OVERALL DIMENSIONS

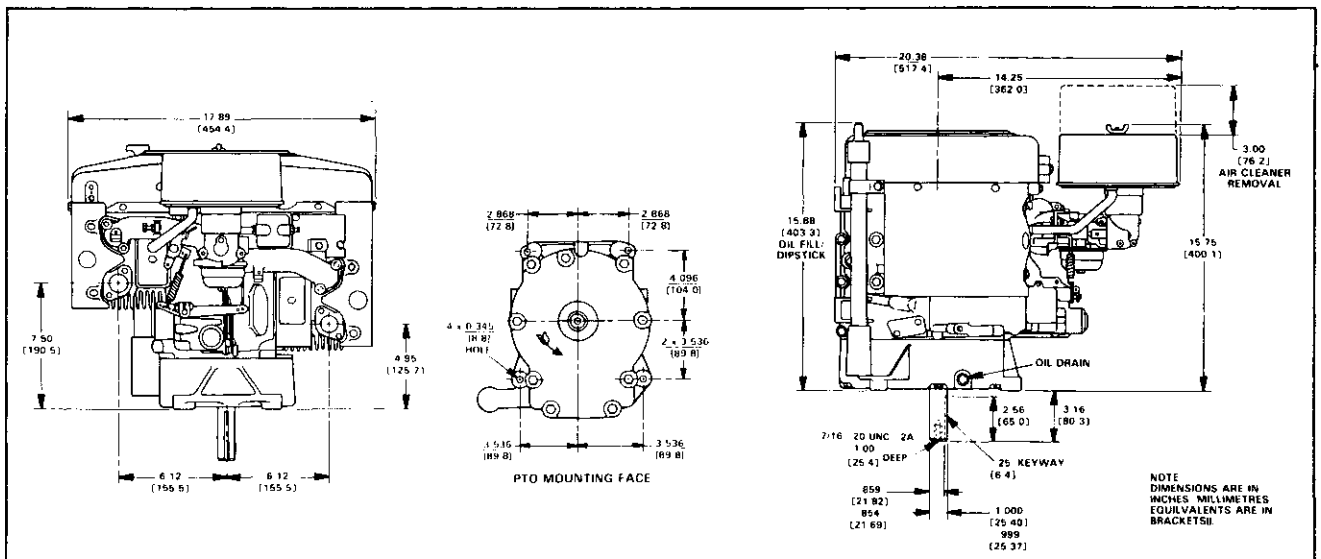

Figure 1-5. Overall Dimensions - Models MV16, MV18 and MV20.

## STANDARD TORQUE VALUES<sup>1</sup>

### Bolts, Screws, Nuts, and Fasteners Assembled Into Cast Iron or Steel



Size	Grade 2	Grade 5 <sup>3</sup>	Grade 8
#8-32	20 in. lb.	25 in. lb.	—
#10-24	32 in. lb.	40 in. lb.	—
#10-32	32 in. lb.	40 in. lb.	—
1/4-20	70 in. lb.	115 in. lb.	165 in. lb.
1/4-28	85 in. lb.	140 in. lb.	200 in. lb.
5/16-18	150 in. lb.	250 in. lb.	350 in. lb.
5/16-24	165 in. lb.	270 in. lb.	30 ft. lb.
3/8-16	260 in. lb.	35 ft. lb.	50 ft. lb.
3/8-24	300 in. lb.	40 ft. lb.	60 ft. lb.
7/16-14	35 ft. lb.	55 ft. lb.	80 ft. lb.
7/16-20	45 ft. lb.	75 ft. lb.	105 ft. lb.
1/2-13	50 ft. lb.	80 ft. lb.	115 ft. lb.
1/2-20	70 ft. lb.	105 ft. lb.	165 ft. lb.
9/16-12	75 ft. lb.	125 ft. lb.	175 ft. lb.
9/16-18	100 ft. lb.	165 ft. lb.	230 ft. lb.
5/8-11	110 ft. lb.	180 ft. lb.	260 ft. lb.
5/8-18	140 ft. lb.	230 ft. lb.	330 ft. lb.
3/4-10	150 ft. lb.	245 ft. lb.	350 ft. lb.
3/4-16	200 ft. lb.	325 ft. lb.	470 ft. lb.

### Bolts, Screws, Nuts, and Fasteners Assembled Into Aluminum



Size	Grade 2	Grade 5	Grade 8
#8-32	20 in. lb.	20 in. lb.	20 in. lb.
#10-24	32 in. lb.	32 in. lb.	32 in. lb.
1/4-20	70 in. lb.	70 in. lb.	70 in. lb.
5/16-18	150 in. lb.	150 in. lb.	150 in. lb.

### Oil Drain Plugs<sup>4</sup>

Size	Into Cast Iron Pans	Into Aluminum Pans
1/4"	150 in. lb.	100 in. lb.
3/8"	180 in. lb.	120 in. lb.
1/2"	20 ft. lb.	13 ft. lb.
3/4"	25 ft. lb.	16 ft. lb.
X-708-1 <sup>5</sup>	20/25 ft. lb.	20/25 ft. lb.

### Conversions

ft. lb. = in. lb. x 12  
in. lb. = ft. lb. ÷ 12  
kgm = ft. lb. x 0.1383  
Nm. = ft. lb. x 1.3558

## SPECIFICATIONS, TOLERANCES, AND SPECIAL TORQUE VALUES<sup>2</sup>

General	Model MV16	Model MV18	Model MV20
Horsepower (@ 3,600 rpm) .....	16	18	20
Displacement (cu. in.) .....	42.18	42.18	46.98
Bore .....	3.12	3.12	3.12
Stroke .....	2.75	2.75	3.06
Compression Ratio .....	5.8:1	6.0:1	6.0:1
Approx. Weight (lb.) .....	130	130	130
Approx. Oil Capacity* Engines Without Filter(U.S. Quarts) .....	1.75	1.75	1.75

\*For best results, fill to "F" mark on dipstick as opposed to adding a given quantity of oil. Always check level on dipstick before adding more oil. On engines equipped with oil filter, an additional 1/2 U.S. pint of oil is required when oil filter is replaced.



	Model MV16	Model MV18	Model MV20
<b>Angle of Operation - Maximum (At Full Oil Level; Intermittent Operation)</b>			
Carb. Side Up .....	30°	30°	30°
Carb. Side Down .....	30°	30°	30°
#1 Cylinder Up .....	25°	25°	25°
#1 Cylinder Down .....	25°	25°	25°
<b>Camshaft</b>			
End Play .....	.003/.013	.003/.013	.003/.013
Camshaft to Camshaft Bearing Running Clearance .....	.0010/.0025	.0010/.0025	.0010/.0025
<b>Carburetor</b>			
Preliminary Idle Fuel Screw Setting (Turns) .....	1¼	1¼	1¼*
Float Level .....	.690/.720	.690/.720	.690/.720
Throttle Plate/Choke Plate Retaining Screw Torque (in. lb.) .....	8/12	8/12	8/12
Main Fuel Jet Torque (in. lb.) .....	12/16	12/16	12/16
Bowl Retaining Scw Torque (in. lb.) .....	45/55	45/55	45/55
<b>Connecting Rod (Posi-Lock)</b>			
New Service Rod Nut Torque (in. lb.) <sup>4, 6</sup> .....	140	140	140
Used Rod Nut Torque (in. lb.) <sup>4, 6</sup> .....	100	100	100
Rod to Crankpin Running Clearance - New .....	.0012/.0024	.0012/.0024	.0012/.0024
Rod to Crankpin Max. Wear Limit .....	.0029	.0029	.0029
Rod to Piston Pin Running Clearance - New .....	.0006/.0011	.0006/.0011	.0006/.0011
Rod Side Play on Crankpin .....	.005/.016	.005/.016	.005/.016
<b>Crankcase/Cylinder Barrel</b>			
Intake and Exhaust Manifold Fastener Torque (in. lb.) .....	150	150	150
Oil Pan Fastener Torque (in. lb.) <sup>7</sup> .....	150	150	150
Cylinder Barrel Nut Torque (in. lb.) <sup>7</sup> .....	200	200	200
Crankcase Nut Torque (in. lb.) <sup>7</sup> .....	260	260	260
5/16" Crankcase Screw Torque (in. lb.) <sup>7</sup> .....	200	200	200
3/8" Crankcase Screw Torque (in. lb.) <sup>7</sup> .....	260	260	260
<b>Crankshaft</b>			
Crankshaft End Play .....	.002/.014	.002/.014	.002/.014
Main Bearing Surface Max. Wear Limit .....	1.7407	1.7407	1.7407
Sleeve Bearing Max. Out of Round .....	.0005	.0005	.0005
Sleeve Bearing Max. Taper .....	.001	.001	.001
New Sleeve Bearing Max. Running Clearance .....	.0049	.0049	.0049
Sleeve Bearing Running Clearance Max. Wear Limit .....	.0059	.0059	.0059
New Sleeve Bearing I.D. (installed) .....	1.7439/1.7461	1.7439/1.7461	1.7439/1.7461
Crankpin O.D. - New .....	1.3733/1.3738	1.3733/1.3738	1.4993/1.4998
Crankpin O.D. Max. Wear Limit .....	1.3728	1.3728	1.4988
Crankpin O.D. Max. Out of Round .....	.0005	.0005	.0005
Crankpin O.D. Max. Taper .....	.001	.001	.001
<b>Cylinder Bore</b>			
I.D. - New .....	3.1245/3.1255	3.1245/3.1255	3.1245/3.1255
I.D. Max. Wear Limit .....	3.128	3.128	3.128
I.D. Max. Out of Round .....	.002	.002	.002
I.D. Max. Taper .....	.0015	.0015	.0015

\*1 turn for High Idle on Walbro Adjustable Jet Carburetor.

	Model MV16	Model MV18	Model MV20
<b>Cylinder Head</b>			
Cap Screw Torque (ft. lb.) <sup>7</sup> .....	15/20	15/20	15/20
Max. Out of Flatness .....	.003	.003	.003
<b>Fan/Flywheel</b>			
Fan Fastener Torque (in. lb.) .....	115	115	115
Flywheel Fastener Torque (ft. lb.) <sup>4</sup> .....	40	40	40
<b>Fuel Pump</b>			
Mounting Screw Torque (in. lb.) .....	40/45	40/45	40/45
<b>Ignition</b>			
Ignition Module to Magnet Air Gap .....	.008/.012	.008/.012	.008/.012
Spark Plug Type (Champion® or Equiv.) .....	RV15YC	RV15YC	RV15YC
Spark Plug Gap .....	0.025	0.025	0.025
Spark Plug Torque (ft. lb.) .....	10/15	10/15	10/15
<b>Oil Fill/Oil Filter<sup>10</sup></b>			
Engine Mtd. Filter Adapter Fastener Torque (in. lb.) .....	125	125	125
Remote Oil Filter Cover Fastener Torque (in. lb.) .....	125	125	125
Remote Oil Line Fitting Nut Torque (in. lb.) .....	65/80	65/80	65/80
Remote Oil Line Reducing Connector Torque (in. lb.) .....	65/80	65/80	65/80
Remote Oil Line Flare Nut Torque (in. lb.) .....	100/120	100/120	100/120
Remote Oil Filter Adapter Fitting Torque (in. lb.) .....	90/130	90/130	90/130
Oil Filter Installation Torque (in. lb.) .....	50/80	50/80	50/80
Oil Filter Bypass Cover Fastener Torque (in. lb.) .....	125	125	125
<b>Oil Pump</b>			
Pump Shaft to Crankcase Running Clearance .....	.0010/.0026	.0010/.0026	.0010/.0026
Pump Drive Gear End Play .....	.010/.029	.010/.029	.010/.029
<b>Piston and Piston Rings (Style "D" Pistons)</b>			
Thrust Face O.D. @ D1 - New <sup>9</sup> .....	3.1203/3.1210	3.1203/3.1210	3.1203/3.1210
Thrust Face O.D. @ D1 - Max. Wear Limit <sup>9</sup> .....	3.1181	3.1181	3.1181
Thrust Face to Bore Clearance @ D1 - New <sup>9</sup> .....	.0035/.0052	.0035/.0052	.0035/.0052
Piston Ring End Gap - New <sup>9</sup> .....	.010/.023	.010/.023	.010/.023
Piston Ring End Gap - Used (Max.) <sup>8</sup> .....	.032	.032	.032
Piston Ring Side Clearance - Max. ....	.006	.006	.006
Piston Pin O.D. - New .....	.6247/.6249	.6247/.6249	.7499/.7501
<b>Valves and Tappets</b>			
Intake Valve to Tappet Clearance - Cold .....	See Page 3.6		
Exhaust Valve to Tappet Clearance - Cold .....	See Page 3.6		
Intake Valve Minimum Lift - Zero Lash .....	.274	.274	.274
Exhaust Valve Minimum Lift - Zero Lash .....	.274	.274	.274
Intake Valve Minimum Stem O.D. ....	.3103	.3103	.3103
Exhaust Valve Minimum Stem O.D. ....	.3088	.3088	.3088
Nominal Valve Seat Angle (Intake & Exhaust) .....	45° & 30°	45° & 30°	45° & 30°
Valve Guide Reamer Size .....	.3125	.3125	.3125
Intake Valve Guide I.D. Max. Wear Limit .....	.005	.005	.005
Exhaust Valve Guide I.D. Max. Wear Limit .....	.007	.007	.007

**Notes:**

1. Use standard torque values when specific values are not given. Standard values have a tolerance of  $\pm 20\%$ .
2. All dimensions are in inches unless otherwise specified.
3. Also applies to self-tapping screws.
4. Lubricate with oil at assembly.
5. 3/8-16 thread with hex head nut and fiber gasket.

- 
6. Torque in increments to the value specified. Do not overtorque—loosen—and retorque hex nuts on Posi-Lock connecting rods.
  7. Refer to the "Reassembly" section for instructions and tightening sequence.
  8. Top and center compression rings.
  9. Measurements @ D1 on Style "D" pistons are made perpendicular to piston pin in the position shown.

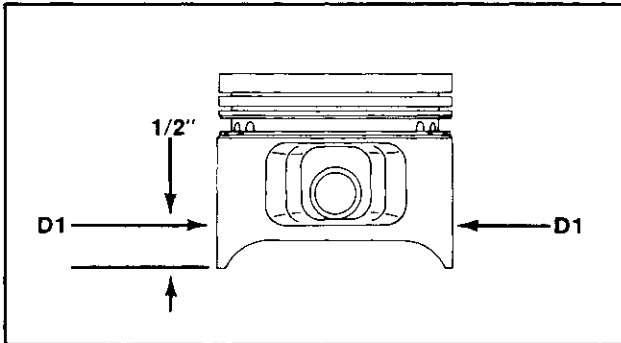

10. Refer to the "Lubrication System" section for additional information.

## SECTION 2 SPECIAL TOOLS

### SPECIAL SERVICE TOOL KIT NO. NU-3211-A

These quality tools are designed to help you perform specific disassembly, repair, and reassembly procedures. By using tools designed for the job, you can service engines easier, faster, and safer! In addition, you'll increase your service capabilities and customer satisfaction by decreasing engine down time.

The Special Service Tool Kit No. NU-3211-A can be ordered complete as shown (Refer to Figure 2-1), or the tools can be ordered individually. Contact your Kohler Distributor for price and availability.

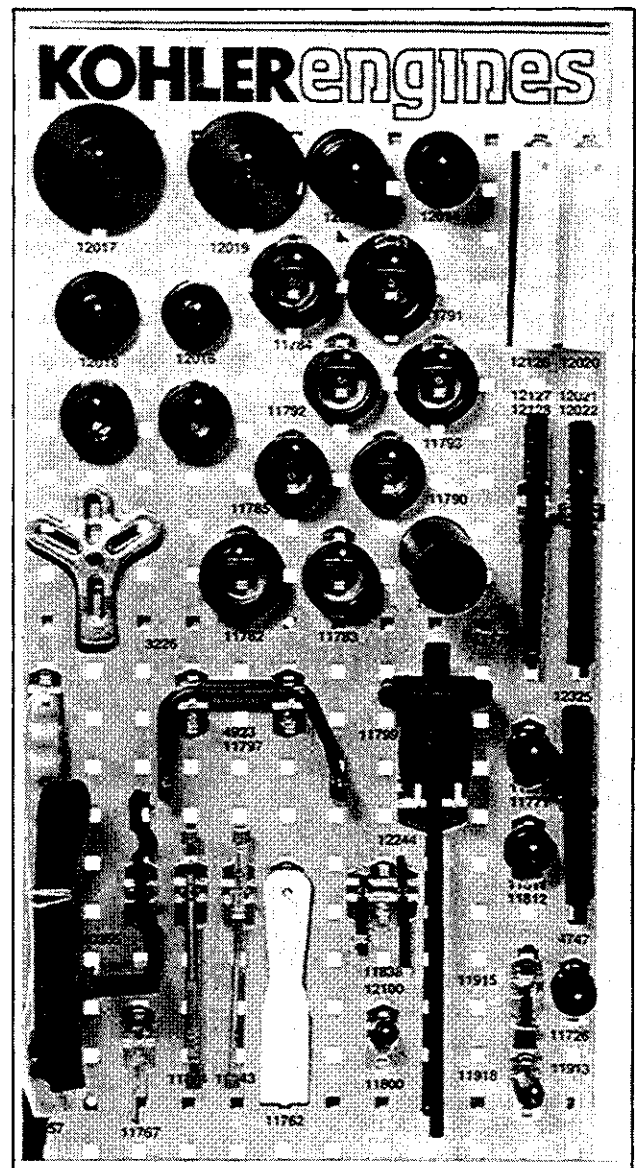

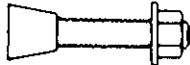

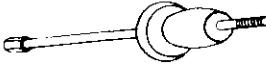
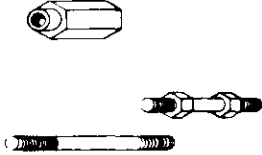
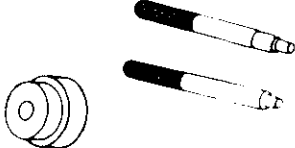
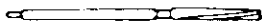
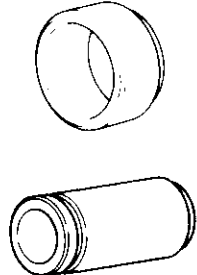



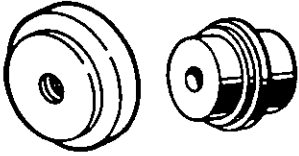
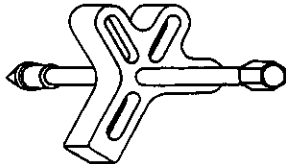

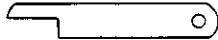
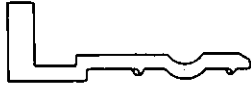

Figure 2-1. Special Service Tool Kit—No. NU-3211-A.

## VALVE SERVICE TOOLS

TOOL NO. & NAME	APPLICATION	ILLUSTRATION
<b>VALVE SEAT PULLERS</b> NU-11726 NU-11913	Removal of valve seats. Use NU-11918 adapter, NU-3222 slide hammer & NU-11915 forcing screw	
<b>FORCING SCREW</b> NU-11915	Used with valve seat pullers NU-11726 & NU-11913	
<b>ADAPTER</b> NU-11918	Used to connect valve seat pullers to slide hammer	
<b>VALVE SEAT INSTALLER</b> NU-11811 NU-11812	Used to install intake and exhaust seats. Use with NU-4747 handle	
<b>NU-3222 SLIDE HAMMER</b> NU-11799 Weight NU-12244 Slide Bolt	Provides pulling force for valve seat and guide removal. Use NU-4747 handle	
<b>NU-3268 VALVE GUIDE REMOVAL KIT</b> NU-11838 Stud 3 1/2" NU-12100 Stud 2 1/2" NU-11800 Adapter NU-0917 Nut NU-12008 Nut	Used to pull valve guides with NU-3222 slide hammer	
<b>NU-3224 VALVE GUIDE INSTALLER KIT</b> NU-12325 Driver NU-11763 Driver NU-11770 Gage NU-11771 Gage	Used to install valve guides to proper depth. Use NU-11763 driver with NU-11770 & NU-11771 depth gages	
<b>REAMERS (Valve Guide)</b> NU-11843 5/16" NU-11844 1/4"	To ream valve guides	

## SEAL AND BEARING INSTALLERS

<b>NU-3223 SEAL INSTALLER KIT</b> NU-11782 Seal Installer NU-11783 Seal Installer NU-11784 Seal Installer NU-11785 Seal Installer NU-11786 Seal Installer NU-11787 Seal Installer NU-11790 Seal Installer NU-11791 Seal Installer NU-11792 Seal Installer NU-11793 Seal Installer NU-11795 Handle	Used to install seals without damage and to proper depth. Use NU-11795 handle with installers	
--	---	---

<b>SEAL AND BEARING INSTALLERS</b>		
<b>TOOL NO. &amp; NAME</b>	<b>APPLICATION</b>	<b>ILLUSTRATION</b>
<b>NU-3242 SEAL PROTECTOR SLEEVE KIT</b> NU-12020 .75" NU-12021 1.00 NU-12022 1.25 NU-12126 1.12 NU-12127 1.50 NU-12128 1.44	Used on crankshaft when installing seals to prevent damage	
<b>NU-3241 BEARING INSTALLING KIT</b> NU-12014 Ins. (Crank Bushing) NU-12015 Ins. (Cam Bushing) NU-12016, NU-12017, NU-12018 & NU-12109 Brg. Installers	Used to install & remove engine bearings and bushings	
<b>OTHER APPLICATIONS</b>		
<b>NU-3226 FLYWHEEL PULLER KIT</b> NU-12485 Puller w/forcing screw NU-5108 Bolt - 1/4" w/washer (3) NU-12505 Bolt - 10-24 w/washer (2) NU-12504 Bolt - 3/8" w/washer (2) NU-12506 Storage Bag	Used to remove flywheels and bearing plates from engine	
<b>FLYWHEEL STRAP WRENCH</b> NU-10357	Used to hold flywheel for nut removal	
<b>OFFSET WRENCH</b> NU-11797 Wrench 1/2" NU-4923 Wrench 9/16"	Used to remove & install cylinder barrel retaining nuts	
<b>FEELER GAGE</b> NU-11767	Used to set oil pump drive gear backlash on twin cylinder engine	
<b>TIMING GAGE</b> NU-10355 Timing Gage	Used to hold balance gears in timed position when assembling engine	
<b>SCRAPER</b> NU-11762	Used to scrape machined surfaces without damage	
<b>HANDLE</b> NU-4747 Handle	Used with bearing installers, slide hammer, and valve seat installers	
<b>TOOL BOARD AND HOOK SET</b> NU-12033	Used to store and identify tools	<b>SEE FRONT PAGE</b>

## KIT NO. NU-3211-A TOOL USAGE CHART

PART NO. & NAME	MODEL ("K" SERIES)											MODELS ("M" SERIES)										
	K-91	K-161	K-181	K-241	K-301	K-321	K-341	KT-17	KT-19	K-532	K-582	M-8	M-10	M-12	M-14	M-16	M-18	M-20	M-16	M-18	All MV	
<b>VALVE TOOLS</b>																						
NU-11726 Valve Seat Puller	•	•	•	•	•	•	•	•	•	•	•	•	•	•	•	•	•	•	•	•	•	•
NU-11913 Valve Seat Puller	•	•	•	•	•	•	•	•	•	•	•	•	•	•	•	•	•	•	•	•	•	•
NU-11915 Forcing Screw	•	•	•	•	•	•	•	•	•	•	•	•	•	•	•	•	•	•	•	•	•	•
NU-11918 Adapter	•	•	•	•	•	•	•	•	•	•	•	•	•	•	•	•	•	•	•	•	•	•
NU-11811 Valve Seat Installer	•	•	•	•	•	•	•	•	•	•	•	•	•	•	•	•	•	•	•	•	•	•
NU-11812 Valve Seat Installer	•																					
NU-3222 Slide Hammer	•	•	•	•	•	•	•	•	•	•	•	•	•	•	•	•	•	•	•	•	•	•
NU-3268 Valve Guide Removal Kit	•	•	•	•	•	•	•	•	•	•	•	•	•	•	•	•	•	•	•	•	•	•
NU-12325 Valve Guide Driver	•	•	•	•	•	•	•					•	•	•	•	•	•	•	•	•	•	•
NU-11763 Valve Guide Driver (depth)								•	•													
NU-11770 Valve Guide Depth Gage								•	*													
NU-11771 Valve Guide Depth Gage								•														
NU-11843 Valve Guide Reamer 3/16"	•	•	•	•	•	•	•	•	•	•	•	•	•	•	•	•	•	•	•	•	•	•
NU-11844 Valve Guide Reamer 1/4"	•																					

\*KT19 Prior to Series II

### BEARING AND SEAL INSTALLERS

NU-12014 Installer — Crank Bushing										•	•											
NU-12015 Installer — Cam Bushing										•	•											
NU-12016 Installer — Bearing	•																					
NU-12017 Installer — Bearing (PTO)										•	•											
NU-12018 Installer — Bearing	•	•										•										
NU-12019 Installer — Bearing			•	•	•	•	•					•	•	•	•	•						
NU-11782 Installer — Seal (PTO)								•	•								•	•				
NU-11783 Installer — Seal (Flywheel)								•	•								•	•	•	•	•	•
NU-11784 Installer — Seal (PTO)			•	•	•	•	•					•	•	•	•	•						
NU-11785 Installer — Seal (PTO)	•	•										•										
NU-11786 Installer — Seal (Flywheel)	•											•										
NU-11787 Installer — Seal (PTO)	•											•										
NU-11790 Installer — Seal (Flywheel)	•	•										•										
NU-11791 Installer — Seal (PTO)										•	•											
NU-11792 Installer — Seal (Flywheel)			•	•	•	•	•					•	•	•	•	•						
NU-11793 Installer — Seal (Flywheel)										•	•											
NU-11795 Handle — Installer Seal	•	•	•	•	•	•	•	•	•	•	•	•	•	•	•	•	•	•	•	•	•	•
NU-12020 Seal Sleeve																						
NU-12021 Seal Sleeve																						
NU-12022 Seal Sleeve																						
NU-12126 Seal Sleeve																						
NU-12127 Seal Sleeve																						
NU-12128 Seal Sleeve																						

### MISCELLANEOUS TOOLS

NU-10357 Flywheel Strap Wrench 1/2"	•	•	•	•	•	•	•	•	•	•	•	•	•	•	•	•	•	•	•	•	•	•
NU-11797 Offset Wrench 1/2"									•	•							•	•	•	•	•	•
NU-4923 Offset Wrench 3/16"									•	•												
NU-11767 Feeler Gauge-Crank (Oil Pump)											•	•										
NU-10355 Timing Tool (Balance Gear)				•	•	•	•							•	•	•	•					
NU-11762 Scraper	•	•	•	•	•	•	•	•	•	•	•	•	•	•	•	•	•	•	•	•	•	•
NU-4747 Drive Handle	•	•	•	•	•	•	•	•	•	•	•	•	•	•	•	•	•	•	•	•	•	•
NU-3226 Flywheel Puller Kit	•	•	•	•	•	•	•	•	•	•	•	•	•	•	•	•	•	•	•	•	•	•

## ENGINE ANALYSIS KIT NO. 25 800 01

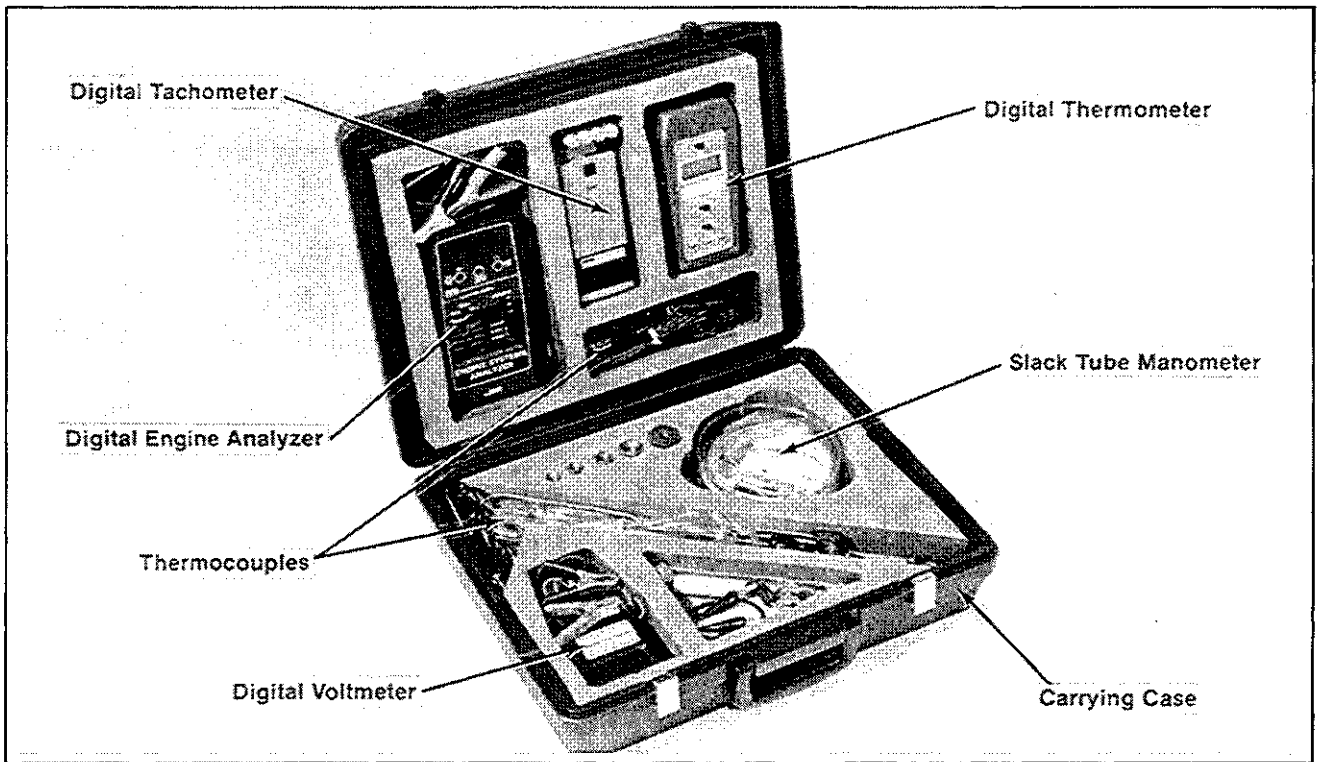

Figure 2-2. Engine Analysis Kit—No. 25 800 01.

The Kohler Engine Analysis Kit contains a selection of instruments which will enable you to measure critical items that relate to engine performance. You will find many uses for these instruments—from basic crankcase vacuum checks to sophisticated application tests.

The kit includes the following:

Qty.	Description	Part No.
1	Digital Voltmeter	25 800 02
1	Digital Tachometer	25 800 03
1	Digital Thermometer	24 800 04
1	Digital Engine Analyzer	25 800 05
1	Slack Tube Manometer	25 800 06
1	8 Ft. Lead With Plug	25 800 07
3	14 mm Spark Plug	
	Thermocouple	25 800 08
2	Head Bolt Thermocouple	25 800 09
1	Oil Sump Thermocouple	25 800 10
1	1/4" x 1/8" Bushing	25 800 11
1	3/8" x 1/8" Bushing	25 800 12
1	1/2" x 1/8" Bushing	25 800 13
1	3/4" x 1/8" Bushing	25 800 14
1	Tube With Fittings	25 800 15
1	Carrying Case	25 800 16
3	Plain Thermocouple	25 800 17

The voltmeter, tachometer, thermometer, and engine analyzer feature state of the art electronic circuitry and digital readouts. Guidelines for using the instruments and testing are included.

Using the instruments in the kit you will be able to:

- Measure temperatures of -
  - spark plug base gasket/cylinder head bolt.
  - oil sump.
  - air into flywheel and carburetor.
- Measure engine speed (RPM).
- Measure crankcase vacuum and exhaust system back pressure.
- Measure voltage.
- Measure charging system current.
- Measure electric starter current (Amp) draw.

The Engine Analysis kit can be ordered complete as shown, or the instruments can be ordered individually. Contact your Kohler Distributor for price and availability.



## IGNITION SYSTEM TESTER

Magnum engines use a state of the art electronic ignition module. A simple tester can be used to determine if the ignition module is functioning properly.

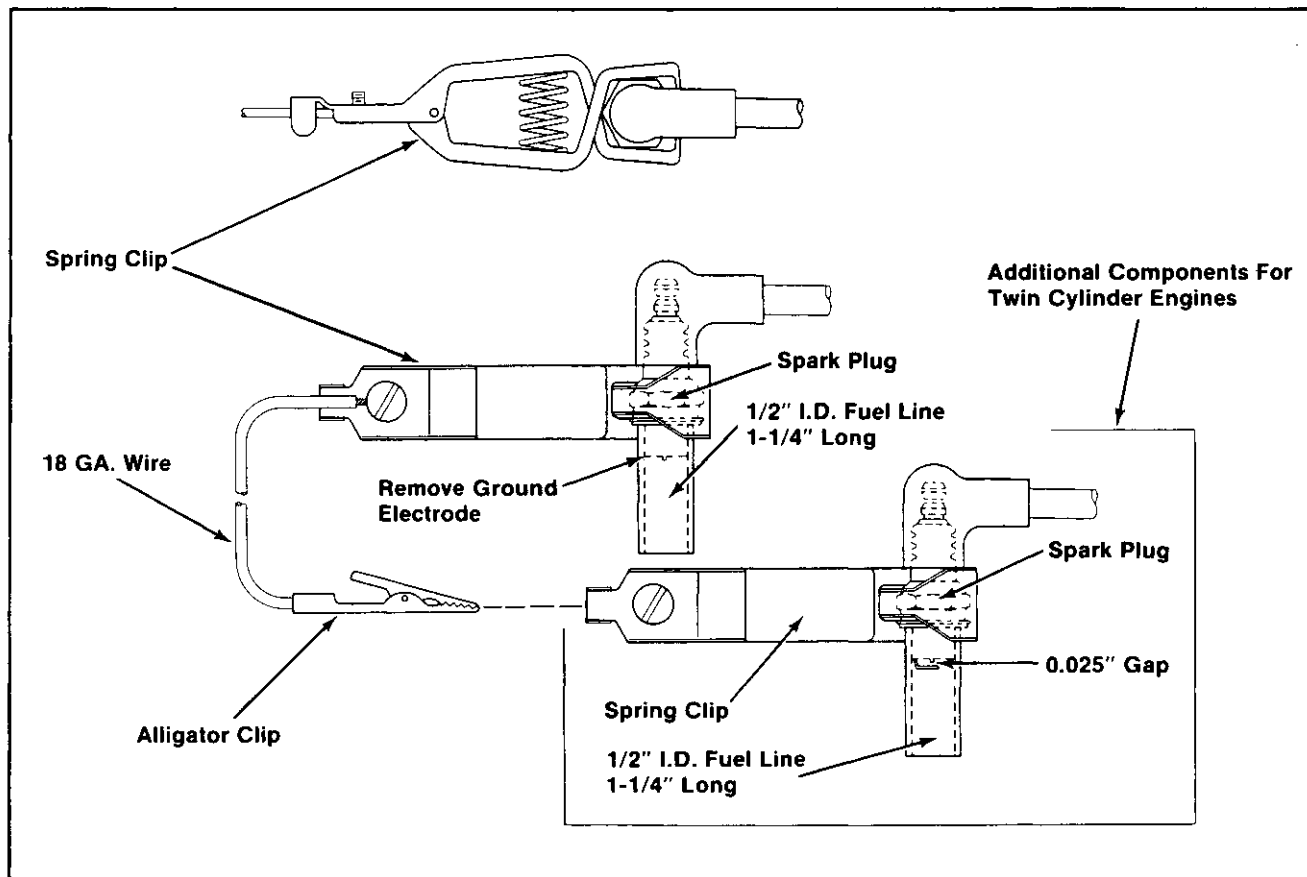

Figure 2-3. Electronic Ignition System Tester.

### For Twin Cylinder Engines

(Models M18, M20, MV16, MV18 and MV20)

1. Use the same tester made for testing single cylinder modules.
2. Obtain another new RJ-8 or RCJ-8 spark plug. Set the gap to **0.025"**.
3. Obtain another large spring clip. Attach the spring clip to the new spark plug. Connect the alligator clip from the single cylinder tester to the screw terminal end of the spring clip.
4. Install a 1-1/4" length of 1/2" I.D. fuel line onto the threads of the new spark plug.

### Using The Tester

Follow the instructions given in the "Electrical System And Components" section.

# SECTION 3 PERIODIC MAINTENANCE

## REQUIRED MAINTENANCE

These required maintenance procedures should be performed at the frequency stated in the table:

Required Maintenance	Frequency
Check Oil Level .....	Daily
Clean Grass Screen .....	Daily*
Check/Replace Fuel Filter .....	As Required
Change Oil and Filter .....	As Specified in "Oil Change Interval" Table
Clean Foam Precleaner .....	25 Hours*
Clean Cooling Fins and External Surfaces .....	50 Hours*
Clean Paper Air Cleaner Element .....	100 Hours*
Check Spark Plugs .....	100 Hours
Check Valve-To-Tappet Clearance .....	500 Hours
Clean Cylinder Heads and Combustion Chambers .....	500 Hours**
Service Starter Motor Drive .....	Annually or 500 Hours

\*Perform these maintenance procedures more frequently when engine is operated under extremely dusty and dirty conditions.

\*\*250 Hours when leaded gasoline is used.

### **WARNING: Accidental Starts!**



*Before servicing the engine or equipment, always remove the spark plug leads to prevent the engine from starting accidentally. Ground the leads to prevent sparks that could cause fires.*

### **CHECK OIL LEVEL**

The importance of checking and maintaining the proper oil level in crankcase cannot be overemphasized. Check oil **BEFORE EACH USE** as follows:

1. Make sure the engine is stopped, level, and is cool so the oil has had time to drain into the sump.
2. Clean the area around dipstick/oil fill tube before removing to keep dirt, grass clippings, etc., out of the engine.

- Remove the oil fill cap/dipstick and wipe oil off. Reinsert the dipstick and push it all the way down into tube. Remove the dipstick and check the level.

The oil level should be up to, but not over, the "F" mark on the dipstick. Refer to Figure 3-1.

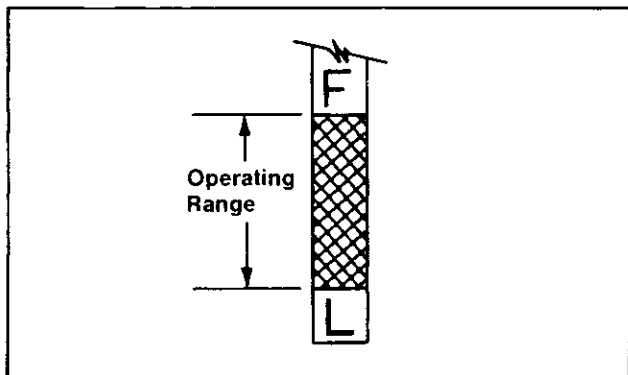

Figure 3-1. Oil Level Operating Range.

- Add the proper type of oil if the level is low. Always check the level with dipstick before adding more oil.

**CAUTION:** Never operate the engine with the oil level below "L" mark or over "F" mark on dipstick.

### Oil Sentry™



Some engines are equipped with optional Oil Sentry oil pressure monitor. Oil Sentry will either stop the engine or activate a "low oil" warning

light, if the oil pressure gets low. Actual Oil Sentry use will vary depending on the engine application.

**CAUTION:** Oil Sentry is not a substitute for checking oil level **BEFORE EACH USE**. Make sure the oil level is maintained up to the "F" mark on dipstick.

### CHANGE OIL

**For a new engine**, change the oil after the first 5 hours of operation. Thereafter, change oil as specified in the "Oil Change Intervals" table.

**For an overhauled engine or those rebuilt with a new Short Block**, use straight 30-weight Service Class SF or SG oil for the first 5 hours of operation. Change the oil after this initial run-in period. Thereafter, change the oil as specified in the "Oil Change Intervals" table.

Drain the oil while the engine is still warm from operation. The oil will flow more freely and carry away more impurities. Change oil as follows:

- Remove the oil drain plug and oil fill cap/dipstick. Refer to Figure 3-2. Tilt the engine slightly towards the drain hole to obtain better drainage.

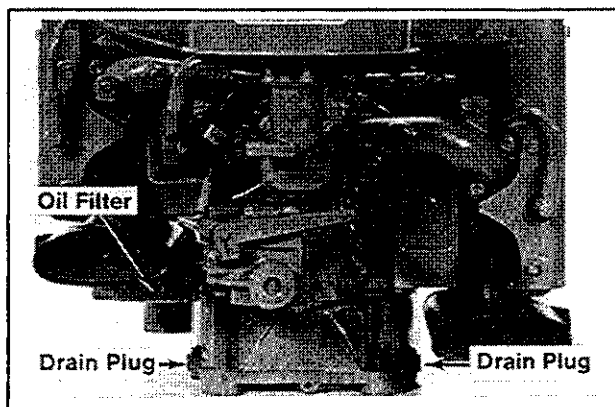

Figure 3-2. Oil Filter And Oil Drain Plug Locations.

### OIL CHANGE INTERVALS

Temperature	Oil Type	Engine Type	Interval
<b>ABOVE 32°F (0°C)</b>	SAE 30	With Filter	50 Hours*
		Without Filter	25 Hours
	Multiviscosity	With Filter	25 Hours
		Without Filter	25 Hours
<b>BELOW 32°F (0°C)</b>	Multiviscosity	With Filter	50 Hours
		Without Filter	25 Hours

\*25 hours for continuous and/or heavy duty operation.

2. Reinstall the drain plug. Make sure it is tightened securely.
3. Fill with new oil of the proper type to the "F" mark on the dipstick. Always check the level on dipstick before adding more oil. Make sure the engine is level when filling and checking oil.

## CHANGE OIL FILTER

Change the oil filter every other oil change, in accordance with the "Oil Change Intervals" table. Always use a genuine Kohler oil filter and change as follows:

1. Drain the crankcase oil, then remove old filter.
2. Before installing the replacement filter, apply a thin coating of oil on surface of the rubber seal.
3. Turn the filter clockwise until the rubber seal contacts the filter adapter, then tighten the filter an additional 1/2 turn.
4. Add an additional 1/2 pint of oil for the filter capacity.
5. Start the engine and check for and correct any oil leaks.

## SERVICE AIR CLEANER

These engines are equipped with a high-density paper air cleaner element. Some specifications are also equipped with an oiled foam precleaner which surrounds the paper element. Refer to Figure 3-3.

Also refer to the "Air Cleaner" section for illustrated disassembly and reassembly procedures.

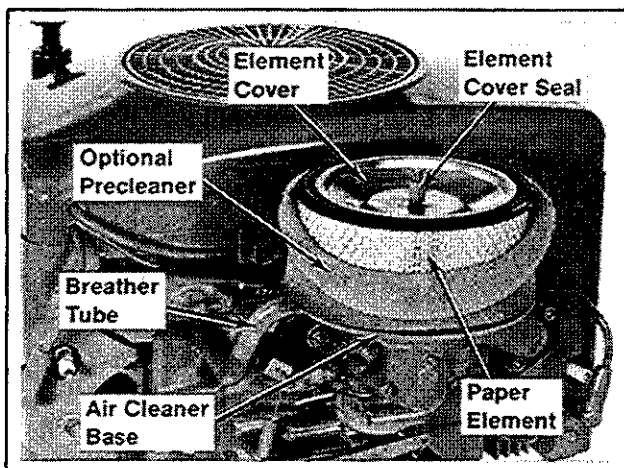

Figure 3-3. Air Cleaner Components.

## Precleaner

If so equipped, wash and reoil the precleaner every 25 operating hours (more often under extremely dusty, dirty conditions).

1. Remove the precleaner from paper element. Wash the precleaner in warm water with detergent.
2. Rinse the precleaner thoroughly until all traces of detergent are eliminated. Squeeze out excess water (do not wring). Allow the precleaner to air dry.
3. Saturate the precleaner in clean, fresh engine oil. Squeeze out excess oil.
4. Reinstall the precleaner over the paper element.

## Paper Element

Every 100 operating hours (more often under extremely dusty or dirty conditions) check the paper element. Replace the element as follows:

1. Remove the precleaner (if so equipped), element cover seal, element cover, and paper element.
2. Replace a dirty, bent or damaged element with a new genuine Kohler element. Handle new elements carefully; do not use if surfaces are bent or damaged.

**CAUTION:** Do not wash the paper element or use compressed air as this will damage element.

3. Reinstall the paper element, element cover, and element cover seal.
4. Install the precleaner (cleaned and oiled) over paper element.
5. Install the air cleaner cover and wing nut. Tighten the wing nut 1/2 to 1 full turn after it contacts the cover—do not overtighten.

## Inspect Air Cleaner Components

Whenever the air cleaner cover is removed, or the element or precleaner are serviced, check the following components:

- **Air Cleaner Base** - Make sure it seals tightly against intake elbow, and is not bent or damaged.

- **Element Cover and Element Cover Seal** - Make sure element cover is not bent or damaged. Make sure element cover seal is in place to ensure the element is sealed tightly between the element cover and air cleaner base.

- **Breather Tube** - Make sure it is sealed tightly in air cleaner base and breather cover.

**CAUTION:** Damaged, worn, or loose air cleaner components could allow unfiltered air into the engine causing premature wear and failure. Replace all damaged or worn components.

### CLEAN AIR INTAKE/COOLING AREAS

To ensure proper cooling, make sure the grass screen, cooling fins, and other external surfaces of engine are kept clean at all times. Refer to Figure 3-4.

Every 50 operating hours (more often under extremely dusty, dirty conditions), remove the blower housing and other cooling shrouds. Clean the cooling fins and external surfaces as necessary. Make sure the cooling shrouds are reinstalled.

Refer to the "Disassembly" and "Reassembly" sections for cooling shroud removal and installation procedures.

**CAUTION:** Operating the engine with a blocked grass screen, dirty or plugged cooling fins, and/or cooling shrouds removed will cause engine damage due to overheating.

### CHECK SPARK PLUGS

Every 100 operating hours, remove the spark plugs, check condition and reset gaps, or replace with new plugs as necessary. Refer to Figure 3-5.

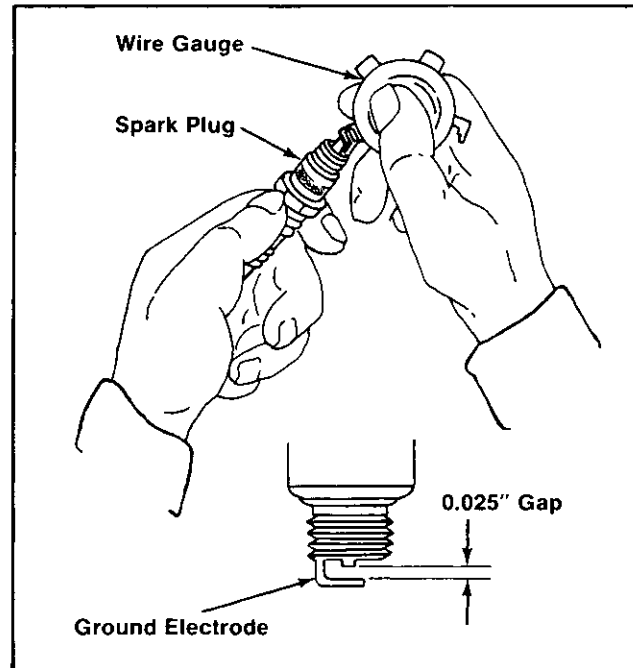

Figure 3-5. Servicing Spark Plugs.

1. Before removing spark plugs, clean the area around the base of plugs to keep dirt and debris out of the engine.

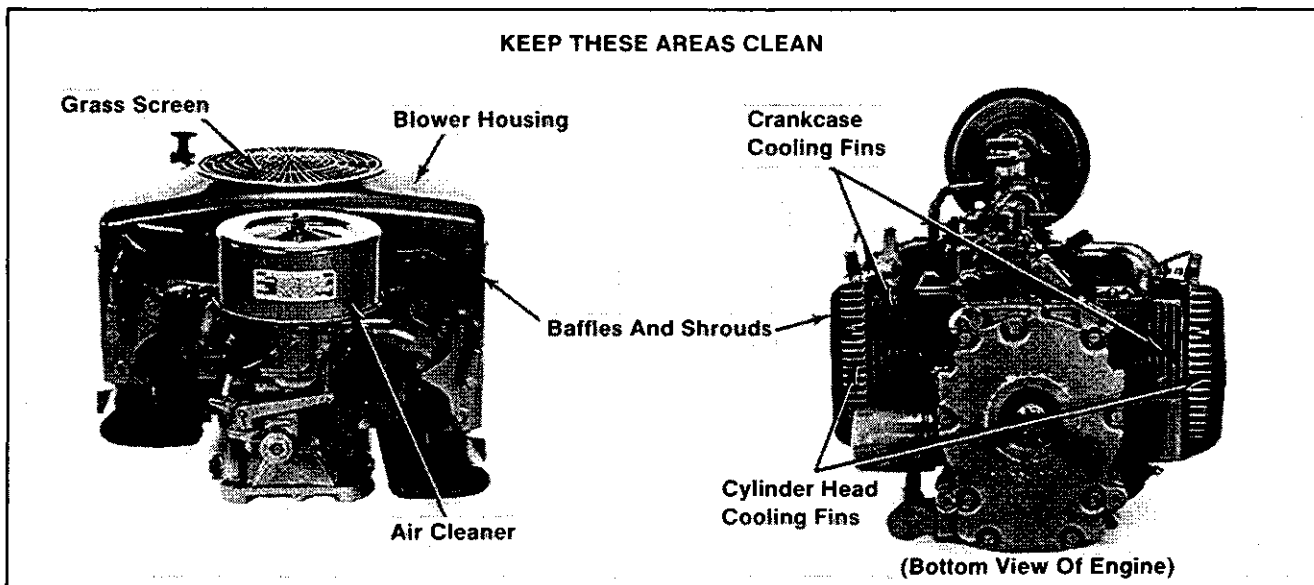

Figure 3-4. Air Intake And Cooling Areas.

2. Remove the plugs and check condition. Replace the plugs if worn or if reuse is questionable.

Use Champion® Type RV15YC or equivalent spark plugs.

**CAUTION:** Do not clean the spark plugs in a machine using abrasive grit. Some grit could remain in spark plugs and enter the engine causing extensive wear and damage.

3. Check gaps using a wire feeler gauge. Adjust gaps to **0.025"** by carefully bending the ground electrode.
4. Reinstall the spark plugs into cylinder heads. Torque plugs to **10/15 ft. lb.**

## IGNITION SYSTEM SERVICE

Magnum engines are equipped with a dependable electronic magneto ignition system. Other than periodically checking/replacing the spark plugs, no maintenance, timing, or adjustments are required with this system.

## CHECK FUEL FILTER (Refer to Figure 3-6.)

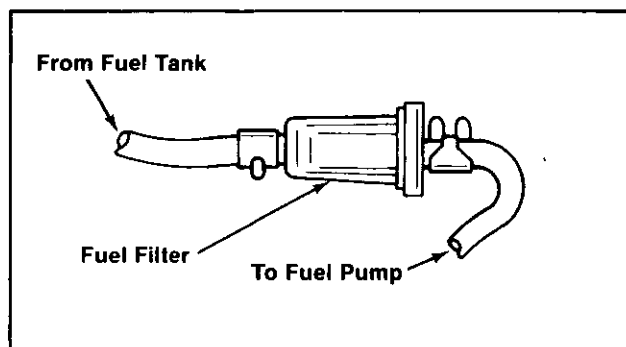

Figure 3-6. In-line Fuel Filter.

Some engines are equipped with an in-line fuel filter. Visually inspect the filter periodically. Replace when dirty with a genuine Kohler filter.

## SERVICE STARTER MOTOR DRIVE

Every 500\* operating hours, or annually (whichever occurs first), clean and lubricate the drive splines of the Bendix-drive electric starter motor. Refer to Figure 3-7.

\*Perform more frequently when operating under dusty and dirty conditions.

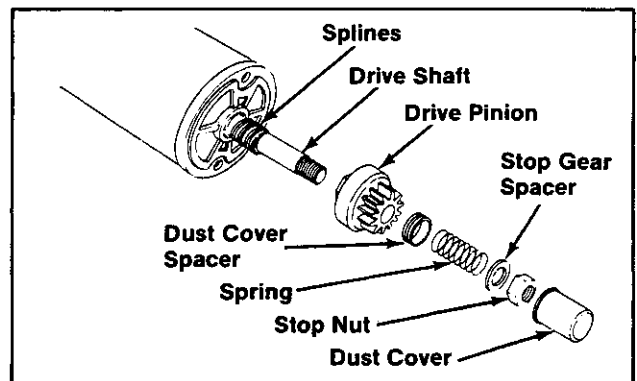

Figure 3-7. Starter Drive Components.

1. Remove the starter from crankcase. (Refer to the "Disassembly" section.)
  2. Remove the dust cover, stop nut, stop gear spacer, spring, dust cover spacer, and drive pinion.
  3. Clean the drive shaft splines with solvent. Dry splines thoroughly.
  4. Apply a small amount of Kohler electric starter drive lubricant (Part No. 52 357 01) to splines.
- CAUTION:** Kohler starter drive lubricant (Part No. 52 357 01) must be used on all Kohler electric starter drives. The use of other lubricants can cause the drive to stick or bind.
5. Apply a small amount of Loctite® No. 271 to stop nut threads. Assemble the drive parts in reverse order of removal. Torque the stop nut to **160 in. lb.**
  6. Reinstall the starter to crankcase.

## CLEAN CYLINDER HEADS AND COMBUSTION CHAMBERS

Every 500 operating hours (250 hours when leaded gasoline is used), remove the cylinder heads and clean the combustion chambers. Refer to Figure 3-8.

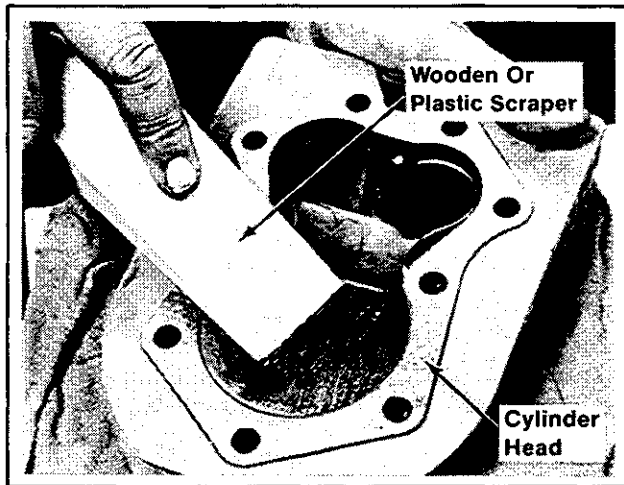

Figure 3-8. Cleaning Cylinder Heads And Combustion Chambers.

1. Remove the cylinder head baffles and cylinder heads.
2. Clean away the combustion deposits using a wooden or plastic scraper.
3. Reinstall the cylinder heads using new gaskets. Torque the cylinder head fasteners to **15/20 ft. lb.** in the sequence specified in Figure 3-9.

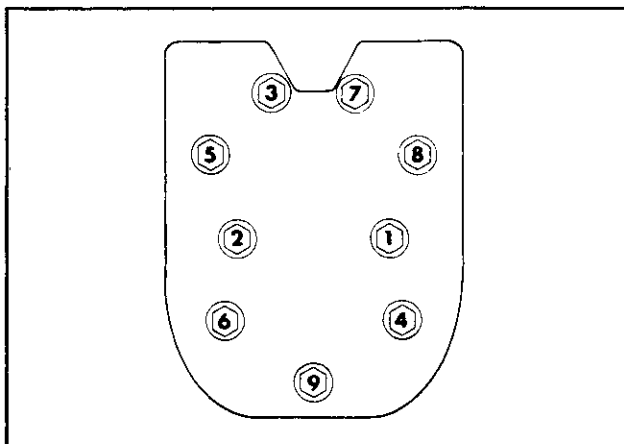

Figure 3-9. Cylinder Head Fastener Tightening Sequence.

## CHECK VALVE-TO-TAPPET CLEARANCE

Every 500 operating hours, remove the breather/valve covers and check valve-to-tappet clearance with a flat feeler gauge. Refer to Figure 3-10. The engine must be cold when checking this clearance.

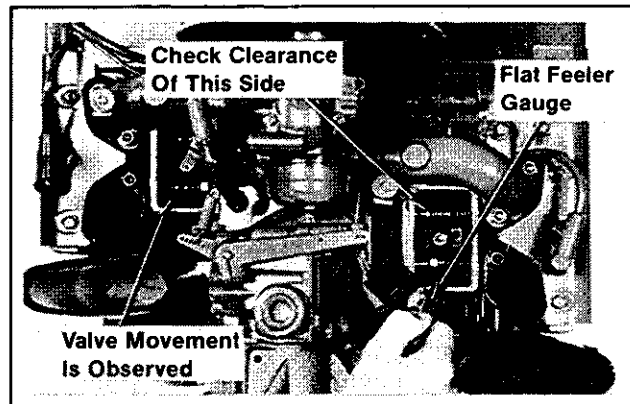

Figure 3-10. Measuring Valve-To-Tappet Clearance.

## Remove Air Cleaner, Valve Covers, Breather, And Spark Plugs

1. Disassemble the air cleaner. Disconnect the breather tube from air cleaner base. Remove the air cleaner base from air intake elbow.
2. Remove the valve cover and breather components from the #1 cylinder barrel. Remove the valve cover from the #2 cylinder barrel.
3. Remove the spark plugs.

## Measure Valve-To-Tappet Clearance

### IMPORTANT:

The piston must be at top dead center (TDC) of the compression stroke to measure valve-to-tappet clearance. By rotating the flywheel and observing the valves and tappets for movement, it can be determined if a cylinder is at TDC.

If, for example, the flywheel is rotated and movement is noticed in the #2 side valve box—the opposite cylinder (#1 side) will be at TDC and valve-to-tappet clearance can be measured.

Rotating the flywheel one complete revolution (360°) will then cause movement in the #1 side valve box—the #2 side cylinder will be at TDC, enabling measurement of valve-to-tappet clearance for that side.

### Clearance Specifications --

	Intake	Exhaust
Before serial no.		
1816500656	.003/.006	.016/.019
After serial no.		
1816500646 but before serial no.1917809296	.003/.006	.011/.014
After serial no.		
1917809286	.003/.006	.013/.016

1. Rotate the flywheel and look into the valve boxes. The valves and tappets will move in only one of the boxes. Measure the valve-to-tappet clearance for the cylinder in which **no movement** was observed—use a flat feeler gauge. Refer to Figure 3-10.
2. Rotate the flywheel 360° and measure the valve-to-tappet clearance for the remaining cylinder.
3. *If clearance is too small*, remove the valves and grind the valve stems until the correct clearance is obtained. Make sure the valve stems are ground perfectly flat and smooth.

*If clearance is too large*, replace the valves and recheck clearance.

NOTE: Large clearances can also be reduced by grinding the valves and/or valve seats. Refer to the "Inspection And Repair/Reconditioning" section for valve specifications.

### **Reinstall Spark Plugs, Breather, Valve Covers, And Air Cleaner**

1. Reinstall the spark plugs and torque to **10/15 ft. lb**
2. Reinstall valve cover to #2 cylinder barrel. Reinstall breather components and breather cover to the #1 cylinder barrel. Make sure the breather is assembled correctly using new gaskets.
3. Reinstall the air cleaner base to intake the air intake elbow using new gasket.
4. Insert the ends of breather tube into holes in air cleaner base and breather cover.

**CAUTION:** Make sure the breather tube seals tightly in breather cover and in air cleaner base to prevent unfiltered air from entering the engine.

5. Reassemble the remaining air cleaner components and tighten wing nut 1/2 to 1 full turn after nut contacts cover. Do not overtighten.

6. Reconnect the spark plug leads.

### **STORAGE**

If the engine will be out of service for approximately two months or more, use the following storage procedure:

1. Change the oil and filter when engine is still warm from operation. Refer to "Change Oil." Run the engine for a few minutes to distribute the clean oil.
2. The fuel system must be completely emptied, or the gasoline must be treated with a stabilizer to prevent deterioration. If you choose to use a stabilizer, follow the manufacturers recommendations, and add the correct amount for the capacity of the fuel system. Fill the fuel tank with clean, fresh gasoline. Run the engine for 2–3 minutes to get stabilized fuel into the carburetor.  
  
To empty the system, drain the fuel tank and carburetor, or run the engine until the tank and system are empty.
3. Remove the spark plugs. Add one tablespoon of engine oil into each spark plug hole. Install plugs, but do not connect plug leads. Crank the engine two or three revolutions.
4. Clean the exterior surfaces of engine. Spread a light film of oil over any exposed metal surfaces of engine to prevent rust.
5. Store the engine in a clean, dry place.



# SECTION 4

## TROUBLESHOOTING

### TROUBLESHOOTING GUIDE

When troubles occur, be sure to check the simple causes which, at first, may seem too obvious to be considered. For example, a starting problem could be caused by an empty fuel tank.

Some common causes of engine troubles are listed below—use this as a guide to locate causing factors.

#### Engine Cranks But Will Not Start

1. Empty fuel tank.
2. Fuel shutoff valve closed.
3. Clogged fuel line.
4. Spark plug leads disconnected.
5. Keyswitch or kill switch in "off" position.
6. Faulty spark plugs.
7. Faulty ignition module.
8. Dirt or water in fuel system.

#### Engine Starts But Does Not Keep Running

1. Restricted fuel tank vent.
2. Dirt or water in fuel system.
3. Faulty choke or throttle controls/cables.
4. Loose wires or connections which short kill terminal of ignition module to ground.
5. Carburetor improperly adjusted.
6. Faulty cylinder head gaskets.
7. Faulty fuel pump.

#### Engine Starts Hard

1. Hydrostatic transmission is not in neutral/PTO drive is engaged.
2. Loose wires or connections.
3. Dirt or water in fuel system.
4. Clogged or restricted fuel lines.
5. Faulty choke or throttle controls/cables.
6. Faulty spark plugs.
7. Carburetor improperly adjusted.
8. Incorrect valve-to-tappet clearance.
9. Low compression.

#### Engine Will Not Crank

1. Hydrostatic transmission is not in neutral/PTO drive is engaged.
2. Battery is discharged.
3. Safety interlock switch is "engaged".
4. Loose or faulty wires or connections.
5. Faulty keyswitch or ignition switch.
6. Faulty electric starter/starter solenoid.
7. Seized internal engine components.

#### Engine Runs But Misses

1. Dirt or water in fuel system.
2. Spark plug leads loose.
3. Loose wires or connections which intermittently short kill terminal of ignition module to ground.
4. Carburetor improperly adjusted.
5. Engine overheating.
6. Incorrect valve-to-tappet clearance.
7. Faulty ignition module.

#### Engine Will Not Idle

1. Idle speed adjusting screw improperly set.
2. Dirt or water in fuel system.
3. Idle fuel adjusting screw improperly set.
4. Restricted fuel tank vent.
5. Faulty spark plugs.
6. Incorrect valve-to-tappet clearance.
7. Low compression.

#### Engine Overheats

1. Grass screen, cooling fins, or shrouding clogged.
2. Excessive engine load.
3. Low crankcase oil level.
4. High crankcase oil level.
5. Carburetor improperly adjusted.

#### Engine Knocks

1. Low crankcase oil level.
2. Excessive engine load.

---

### Engine Loses Power

1. Low crankcase oil level.
2. High crankcase oil level.
3. Restricted air cleaner element.
4. Dirt or water in fuel system.
5. Excessive engine load.
6. Engine overheating.
7. Faulty spark plugs.
8. Carburetor improperly adjusted.
9. Low compression.

### Engine Uses Excessive Amount of Oil

1. Incorrect oil viscosity or type.
2. Clogged or improperly assembled breather system.
3. Worn or broken piston rings.
4. Worn cylinder bores.
5. Worn valve stems and/or valve guides.

## EXTERNAL ENGINE INSPECTION

Before cleaning or disassembling the engine, check its external appearance and condition. This inspection can give clues to what might be found inside the engine (and the cause) once it is disassembled.

- Check for buildup of dirt and debris on the crankcase, cooling fins, grass screen, and other external surfaces. Dirt or debris in these areas are causes of overheating.
- Check for obvious fuel and oil leaks, and damaged components. Excessive oil leakage can indicate a clogged or improperly assembled breather, worn or damaged seals and gaskets, or loose or improperly torqued fasteners.
- Check the air cleaner cover, element cover, and air cleaner base for damage or indications of improper fit and seal. Also check the seal on the air cleaner cover wing nut. A missing or damaged seals could allow dirt to enter the engine.
- Check the air cleaner element. Look for holes, tears, cracked or damaged sealing surfaces, or other damage that could allow dirt to enter the engine. Also note if the element is clogged or restricted. These could indicate that the air cleaner has been underserviced.
- Check the carburetor throat for dirt. Dirt in the throat is further indication that the air cleaner is not functioning properly.
- Check the oil level. Note if the oil level is within the operating range on the dipstick, or if it's low or overfilled.

- Check the condition of the oil. Drain the oil into a container—it should flow freely. Check for metal chips and other foreign particles.

NOTE: It is good practice to drain oil at a location away from the workbench. Be sure to allow ample time for complete drainage.

Sludge is a natural by-product of combustion; a small accumulation is normal. Excessive sludge formation could indicate that the oil has not been changed as recommended, an incorrect type or weight of oil was used, overrich carburetor settings, and weak ignition, to name a few.

## CLEANING THE ENGINE

After inspecting the external condition of the engine, clean it thoroughly before disassembling. Also clean individual components as the engine is disassembled. Only clean parts can be accurately inspected and gauged for wear or damage.

There are many commercially available cleaners that quickly remove grease, oil, and grime from engine parts. When such a cleaner is used, *follow the manufacturer's instructions carefully*. Make sure all traces of the cleaner are removed before the engine is reassembled and placed in operation. Even small amounts of these cleaners quickly break down the lubricating properties of engine oil.

## BASIC ENGINE TESTS

### Crankcase Vacuum

A partial vacuum should be present in the crankcase when the engine is operating at normal temperatures. Pressure in the crankcase (usually caused by a clogged or improperly assembled breather) can cause oil to be forced out at oil seals, gaskets, or other available spots.

Crankcase vacuum is best measured with a slack tube manometer. The manometer included in the Kohler Engine Analysis kit is recommended. Refer to the "Special Tools" section for more information.

## Crankcase Vacuum Test

To test crankcase vacuum with the manometer:

1. Insert the stopper/hose into the oil fill hole. Leave the other vent of manometer open to atmosphere. Make sure the shutoff clamp is closed.
2. Start the engine and run at high speed (3200 to 3750 RPM).
3. Open the clamp and note the water level in the tube. The level in the engine side should be **7 to 14 in.** above the level in the open side. If there is no vacuum (level in engine side is the same as open side) or a positive pressure (level in open side is higher than engine side) check for the conditions below.
4. Close the shutoff clamp **before** stopping the engine.

### NO CRANKCASE VACUUM/PRESSURE IN CRANKCASE

Possible Cause	Solution
1. Crankcase breather clogged or inoperative.	1. Disassemble breather, clean parts thoroughly, reassemble, and recheck pressure.
2. Seals and/or gaskets leaking. Loose or improperly torqued fasteners.	2. Replace all worn or damaged seals and gaskets. Make sure fasteners are tightened securely. Use appropriate torque values and sequences when necessary.
3. Piston blowby or leaky valves. (Confirm by testing compression.)	3. Recondition pistons, rings, cylinder bores, valves, and valve guides.
4. Restricted exhaust.	4. Replace restricted muffler/exhaust system.

## Compression Test

To test compression:

1. Remove the spark plugs. Install compression tester in each spark plug hole.
2. Set the throttle and choke controls to the wide open position. Make sure air cleaner and exhaust system are not restricted.
3. Crank the engine using the starting motor. Take several readings for both cylinders.  
  
If the difference in pressure between cylinders is 15% or greater, or pressure is less than 90 psig, check for the conditions below:

### LOW COMPRESSION

Possible Cause	Solution
1. Blown cylinder head gaskets.	1. Remove cylinder heads, inspect heads for flatness (replace heads if necessary), replace gaskets, reinstall heads, and recheck compression. Locate and correct the cause of initial failure.
2. Warped or loose cylinder heads.	2. Remove cylinder heads, check for flatness (replace heads if necessary). Make sure cylinder head fasteners are torqued in the proper sequence to the proper value.
3. Excessive combustion chamber deposits.	3. Remove cylinder heads and clean deposits from combustion chamber.
4. Worn piston rings - blowby occurring.	4. Recondition piston rings and cylinder bores.
5. Worn valves.	5. Recondition valves and valve seals.

# SECTION 5 AIR CLEANER

These engines are equipped with a high-density paper air cleaner element. Some specifications are also equipped with an oiled foam precleaner which surrounds the paper element. Refer to Figure 5-1, 5-2, and 5-3.

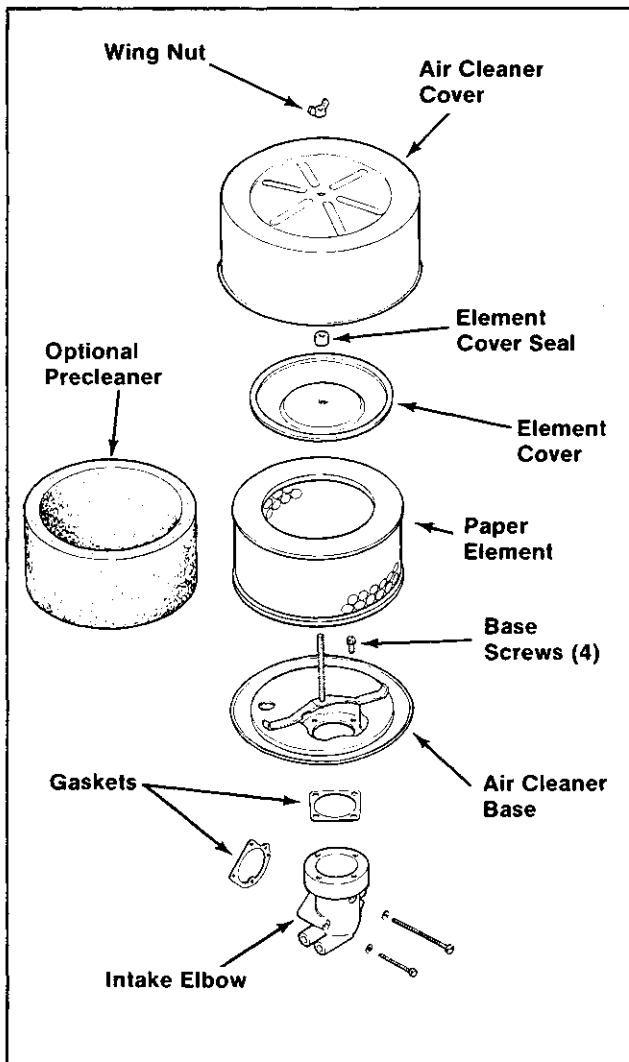

Figure 5-1. Air Cleaner Components—Exploded View.

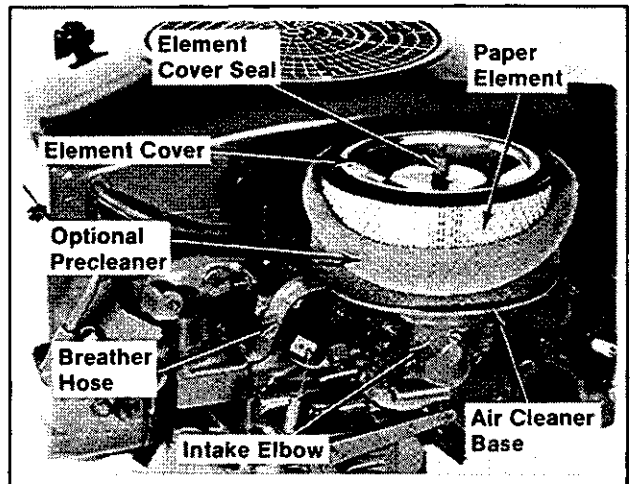

Figure 5-2. Air Cleaner Components.

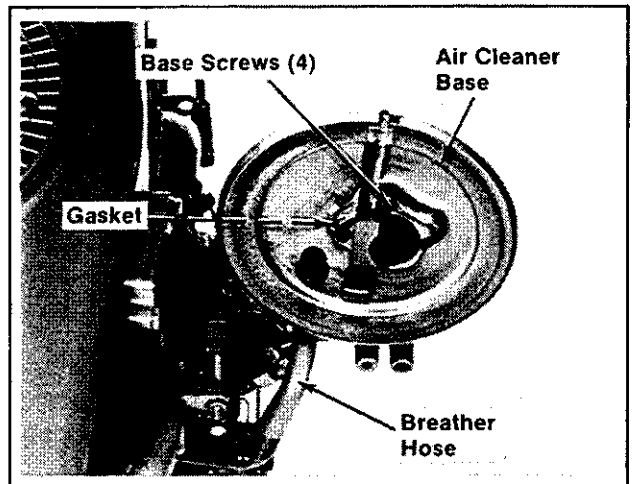

Figure 5-3. Air Cleaner Components.

---

## DISASSEMBLY

1. Remove the wing nut and air cleaner cover.
2. Remove the element cover seal, element cover, paper element, and precleaner (if so equipped).
3. Remove the breather hose, base screws, air cleaner base, and gasket.

## REASSEMBLY

1. Install the gasket, air cleaner base, base screws, and breather hose.

**CAUTION:** Make sure the breather hose seals tightly in the air cleaner base and breather cover to prevent unfiltered air from entering the engine.

2. Install the paper element, precleaner (cleaned and oiled), element cover, and element cover seal.
3. Install the air cleaner cover and wing nut. Tighten wing nut 1/2 to 1 full turn after nut contacts cover—do not overtighten.

## SERVICE

### Precleaner

If so equipped, wash and reoil the precleaner every 25 operating hours (more often under extremely dusty or dirty conditions).

1. Remove the precleaner from paper element. Wash the precleaner in warm water with detergent.
2. Rinse the precleaner thoroughly until all traces of detergent are eliminated. Squeeze out excess water (do not wring). Allow precleaner to air dry.
3. Saturate the precleaner in clean, fresh engine oil. Squeeze out excess oil.
4. Reinstall the precleaner over the paper element.

### Paper Element

Every 100 operating hours (more often under extremely dusty or dirty conditions) check the paper element. Replace the element as follows:

1. Remove the precleaner (if so equipped), element cover seal, element cover, and paper element.

2. Replace a dirty, bent or damaged element with a new genuine Kohler element. Handle new elements carefully; do not use if surfaces are bent or damaged.

**CAUTION:** Do not wash the paper element or use compressed air as this will damage the element.

3. Reinstall the precleaner (cleaned and oiled) over the paper element.
4. Reinstall the paper element, element cover, and element cover seal. Make sure the element is sealed tightly against the element cover and air cleaner base.
5. Install the air cleaner cover and wing nut. Tighten wing nut 1/2 to 1 full turn after nut contacts cover—do not overtighten.

## Inspect Air Cleaner Components

Whenever the air cleaner cover is removed, or servicing the element or precleaner, check the following components:

- **Air Cleaner Base** - Make sure it seals tightly against intake elbow, and is not bent or damaged.
- **Element Cover and Element Cover Seals** - Make sure element cover is not bent or damaged. Make sure element cover seals are in place to ensure element is sealed tightly between element cover and air cleaner base.
- **Breather Tube** - Make sure it is sealed tightly in air cleaner base and breather cover.

**CAUTION:** Damaged, worn, or loose air cleaner components could allow unfiltered air into the engine causing premature wear and failure. Replace all damaged or worn components.

# SECTION 6

## FUEL SYSTEM AND GOVERNOR

### FUEL SYSTEM

The typical fuel system and related components include the fuel tank with vented cap, in-line fuel filter, fuel pump, carburetor, and interconnecting fuel line. Refer to Figure 6-1.

### Operation

The fuel from the tank is moved through the in-line filter and fuel lines by the fuel pump. Fuel then enters the carburetor float bowl and is moved into the carburetor body where it is mixed with air. This fuel-air mixture is then burned in the engine combustion chambers.

### Troubleshooting

Use the following procedure to check if fuel is reaching the combustion chamber.

#### **WARNING: Explosive Fuel!**



*Gasoline is extremely flammable and its vapors can explode if ignited. Before troubleshooting the fuel system, make sure there are no sources of heat, flames, or sparks nearby as these can ignite gasoline vapors. Disconnect and ground the spark plug leads to eliminate the possibility of sparks from the ignition system.*

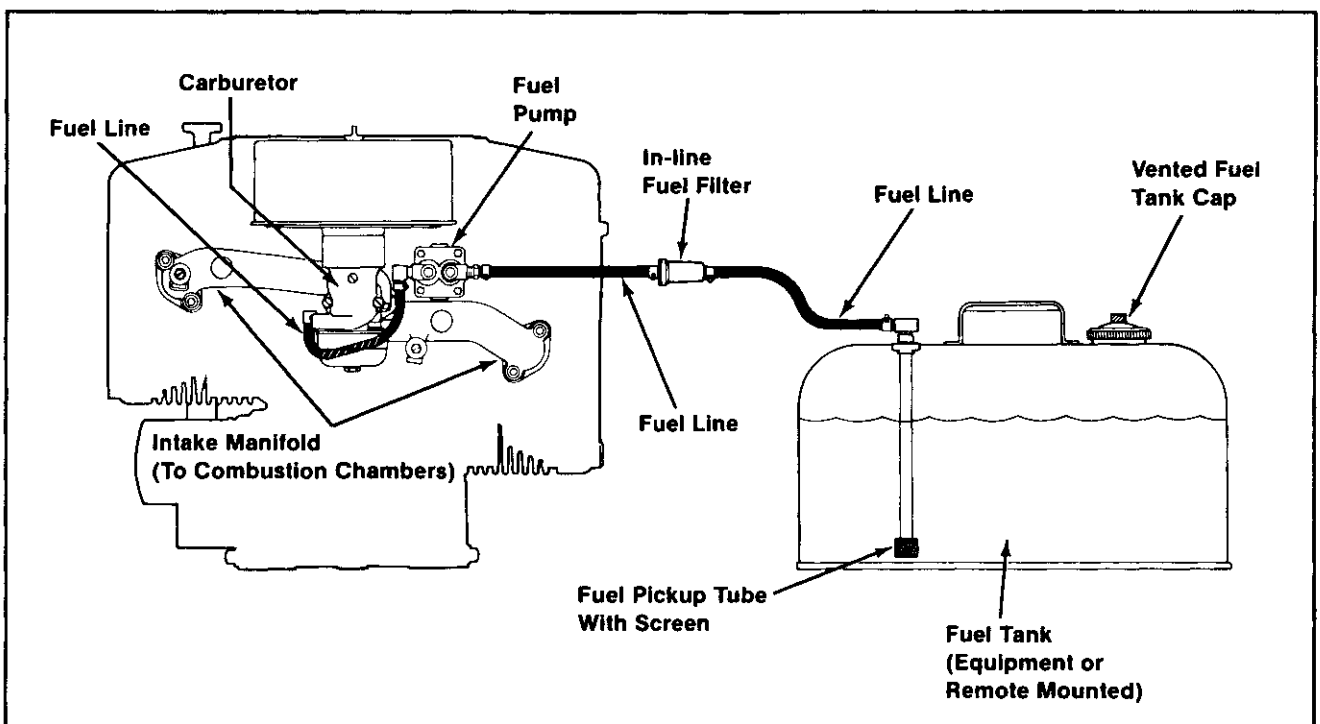

Figure 6-1. Typical Fuel System.

Test	Conclusion
<p><b>1. Check for the following:</b></p> <p>A. Make sure the fuel tank contains fuel.</p> <p>B. Make sure the vent in fuel tank cap is open.</p> <p>C. Make sure the fuel shutoff valve is open.</p>	
<p><b>2. Check for fuel in the combustion chamber.</b></p> <p>A. Disconnect the spark plug leads.</p> <p>B. Close the choke on carburetor.</p> <p>C. Crank the engine several times.</p> <p>D. Remove the spark plugs and check for fuel at tips.</p>	<p>2. If there <b>is</b> fuel at tips of spark plugs, fuel is reaching the combustion chambers.</p> <p>If there is <b>no</b> fuel at tips of spark plugs, check for fuel flow from the fuel tank. (Test 3)</p>
<p><b>3. Check for fuel flow from the fuel tank to fuel pump.</b></p> <p>A. Remove the fuel line from inlet fitting of fuel pump.</p> <p>B. Hold the line below the bottom of tank. Open the shutoff valve (if so equipped) and observe flow.</p>	<p>3. If fuel <b>does</b> flow from line, check for faulty fuel pump. (Test 4).</p> <p>If fuel <b>does not</b> flow from line, check for clogged fuel tank vent, clogged fuel tank vent, shutoff valve, screen, and fuel lines.</p>
<p><b>4. Check operation of fuel pump.</b></p> <p>A. Remove the fuel line from inlet fitting of carburetor.</p> <p>B. Crank the engine several times and observe flow.</p>	<p>4. If fuel <b>does not</b> flow from line, check for clogged fuel line. If line is unobstructed, fuel pump is faulty and must be replaced.</p> <p>If fuel <b>does</b> flow from fuel line, the carburetor is probably faulty. Refer to the "Fixed Jet Carburetor" portion of this section.</p>

## FUEL FILTER

Some engines are equipped with an in-line fuel filter. Visually inspect the filter periodically. Replace when dirty with a genuine Kohler filter. Refer to Figure 6-2.

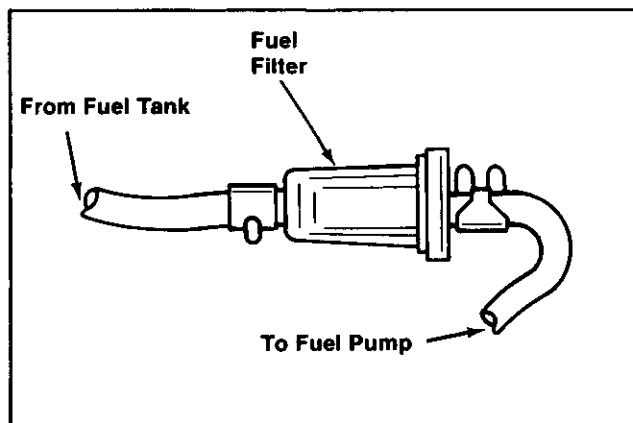

Figure 6-2. In-line Fuel Filter.

## FUEL PUMP

Most Magnum engines are equipped with a mechanically operated fuel pump. On applications using a gravity feed fuel system, the fuel pump is not used and the pump mounting pad on the crankcase is covered.

The fuel pump body is constructed of a nylon material. The nylon body insulates the fuel from the hot engine crankcase and prevents fuel from vaporizing inside the pump.

### Operation

The mechanical fuel pump is operated by a lever which rides on the engine camshaft. The lever transmits a pumping action to the diaphragm inside the pump body. This pumping action draws fuel in through the inlet check valve on the downward stroke of diaphragm. On the upward stroke of the diaphragm, the fuel is forced out through the outlet check valve. Refer to Figure 6-3.

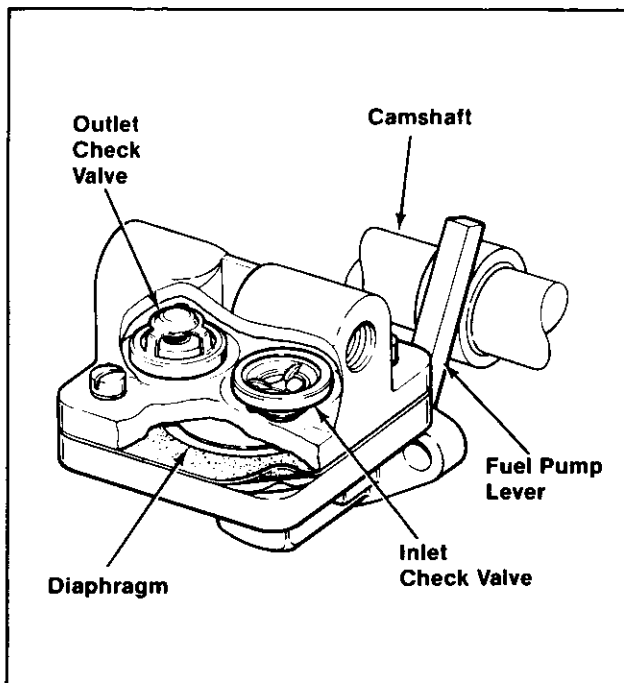

Figure 6-3. Mechanical Fuel Pump.

### Removal

1. Disconnect the fuel lines from the inlet and outlet fittings of pump.
2. Remove the truss head nylock screws, fuel pump, and gasket.
3. If necessary, remove the fittings from pump body.

### Repair

Nylon-bodied fuel pumps are not serviceable and must be replaced when faulty. Replacement pumps are available in kits which include the pump, mounting gasket, and plain washers.

### Installation

(Refer to Figure 6-4.)

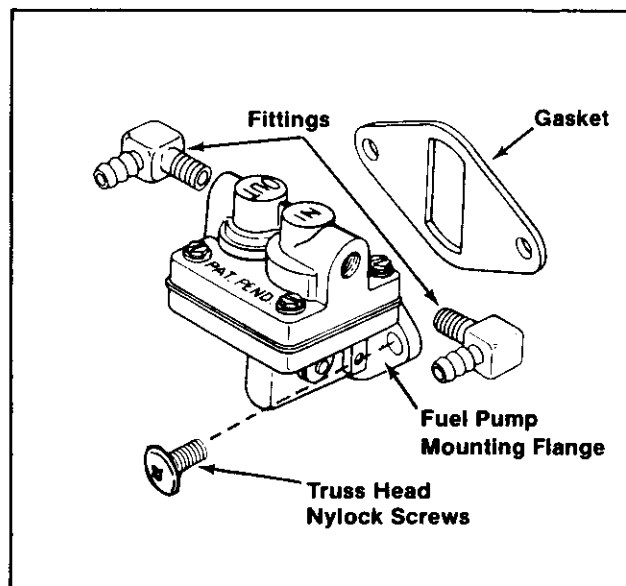

Figure 6-4. Installing Fuel Pump.

1. **Fittings** - Apply a small amount of Permatex® Aviation Perm-A-Gasket (or equivalent) gasoline resistant thread sealant to fittings. Turn the fittings into pump **6 full turns**; continue turning fittings in the same direction until the desired position is reached.
2. Install new gasket, fuel pump, and truss head nylock screws.

**CAUTION:** Make sure the fuel pump lever is positioned above the camshaft. Damage to the fuel pump, and subsequent severe engine damage could result if the lever is positioned below the camshaft.

Torque screws to **40/45 in. lb.**

3. Connect fuel lines to inlet and outlet fittings.



## FIXED JET CARBURETOR

Magnum MV engines are equipped with both fixed and adjustable main jet side draft carburetors. These carburetors are built to Kohler Co. specifications by Walbro Corp.

This sub-section covers the adjustment, dis-assembly, cleaning, inspection, repair and re-assembly of Walbro built side-draft carburetors.

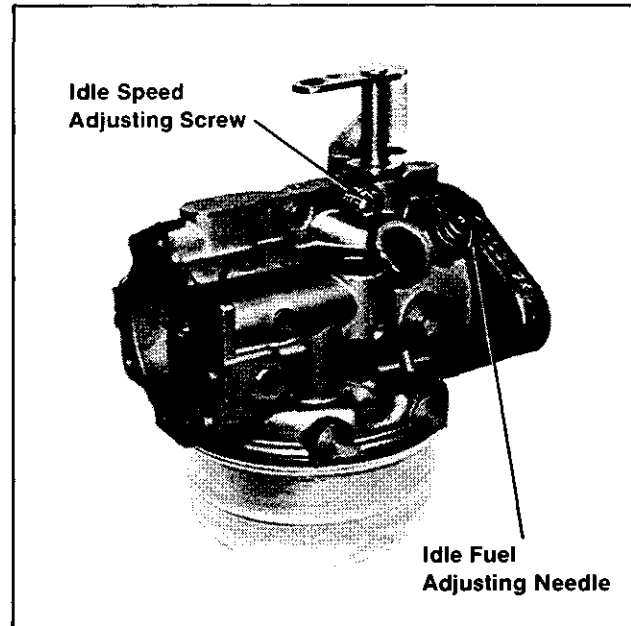

Figure 6-5. Fixed Main Jet Carburetor.

**WARNING: Explosive Fuel!**



*Gasoline may be present in the carburetor and fuel system. Gasoline is extremely flammable and its vapors can explode if ignited. Keep sparks, open flame, and other sources of ignition away from the area to prevent the possibility of fires or explosions.*

**WARNING: Prevent Eye Injury!**



*Suitable eye protection (safety glasses, goggles, or face shield) should be worn for any procedure involving the use of compressed air, punches, hammers, chisels, drills, or grinding tools.*

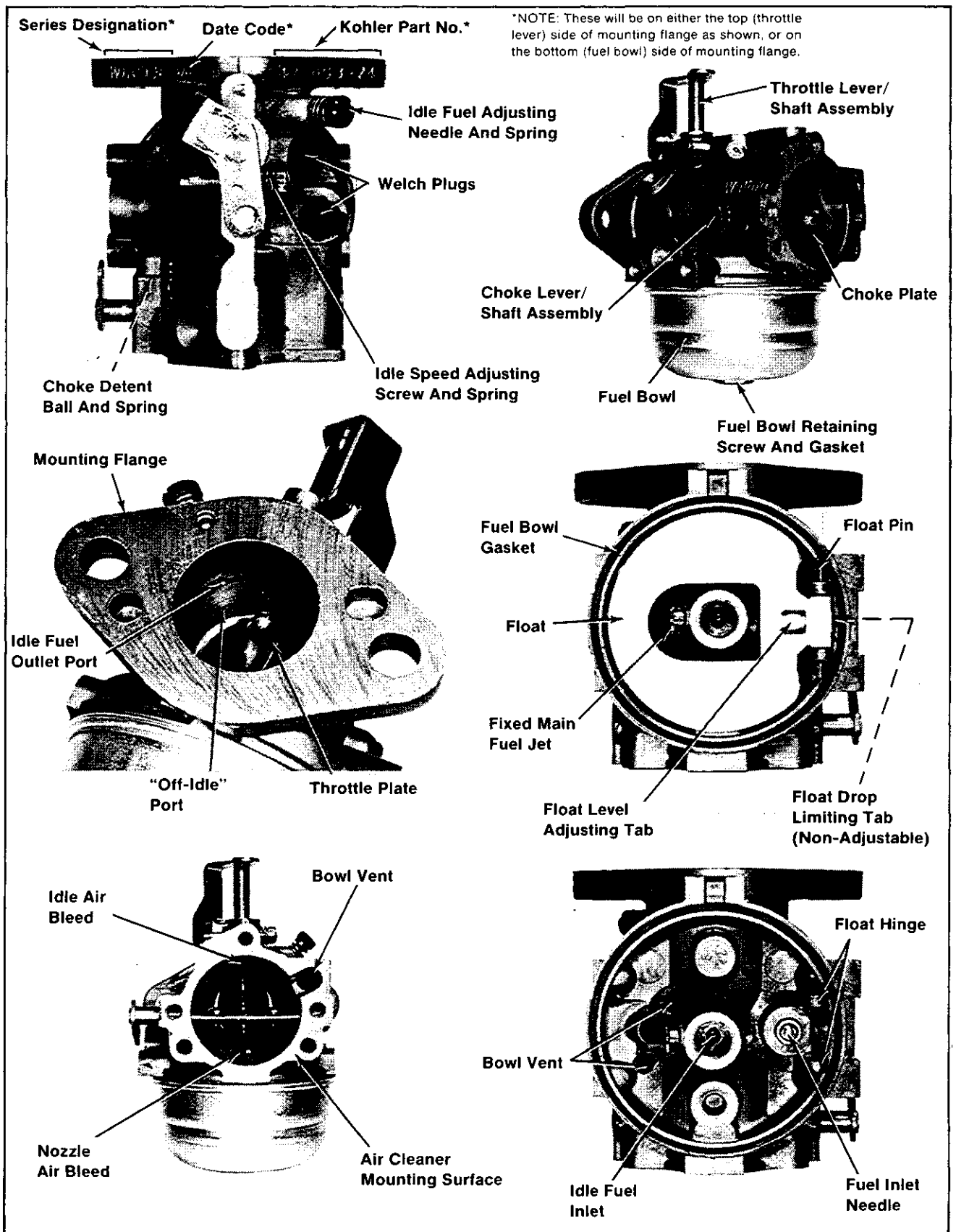

Figure 6-6. Major Components And Service Locations — Typical Fixed Jet Carburetor.

## Troubleshooting

If engine troubles are experienced that appear to be fuel system related, check the following areas before adjusting or disassembling the carburetor.

- Make sure the fuel tank is filled with clean, fresh gasoline.
- Make sure the fuel tank cap vent is not blocked and that it is operating properly.
- Make sure fuel is reaching the carburetor. This includes checking the fuel shut-off valve, fuel tank filter screen, in-line fuel filter, fuel lines, and fuel pump for restrictions or faulty components as necessary.

- Make sure the carburetor is securely fastened to the engine using gaskets in good condition.
- Make sure the air cleaner element is clean and all air cleaner components are fastened securely.
- Make sure the ignition system, governor system, exhaust system, and throttle and choke controls are operating properly.

If, after checking the items listed above, starting problems or other conditions similar to those listed in the following table exist, it may be necessary to adjust or service the carburetor.

Condition	Possible Cause/Probable Remedy
1. Engine starts hard, or runs roughly or stalls at idle speed.	1. Idle fuel mixture or idle speed are improperly adjusted. Adjust the idle speed screw, then adjust idle fuel needle.
2. Engine runs rich. (Indicated by black, sooty exhaust smoke, misfiring, loss of speed and power, governor hunting, or excessive throttle opening.)	2a. Choke partially closed during operation. Check the choke lever and linkage to ensure choke is opening after warm-up. b. Idle fuel mixture is improperly adjusted. Adjust idle fuel needle. c. Float level set too high. With fuel bowl removed and carburetor inverted, set exposed surface of float parallel with the bowl gasket surface of carburetor body. d. Dirt under fuel inlet needle. Remove needle. Clean needle and seat and blow with compressed air. e. Bowl vent or air bleeds plugged. Remove fuel bowl, idle fuel adjusting needle, and welch plugs. Clean vent, ports, and air bleeds. Blow out all passages with compressed air. f. Fuel bowl gasket leaks. Remove fuel bowl and replace gasket. g. Leaky, cracked, or damaged float. Submerge float to check for leaks.
3. Engine runs lean. (Indicated by misfiring, loss of speed and power, governor hunting, or excessive throttle opening.)	3a. Idle fuel mixture is improperly adjusted. Adjust idle fuel needle. b. Float level set too low. With fuel bowl removed and carburetor inverted, set exposed surface of float parallel with the bowl gasket surface of carburetor body. c. Idle holes plugged; dirt in fuel delivery channels. Remove fuel bowl, idle fuel adjusting needle, main fuel jet, and welch plugs. Clean all passages and blow out with compressed air.
4. Fuel leaks from carburetor.	4a. Float level set too high. See Remedy 2c. b. Dirt under fuel inlet needle. See Remedy 2d. c. Bowl vent plugged. Remove fuel bowl and clean bowl vent. Blow out with compressed air. d. Float is cracked or damaged. Replace float. e. Bowl retaining screw gasket damaged. Replace gasket. f. Bowl retaining screw is not tightened. Torque screw to specifications.

## Adjustment

In general, turning the adjusting needles in (clockwise) decreases the supply of fuel to the carburetor. This gives a *leaner* fuel/air mixture. Turning the adjusting needles out (counterclockwise) increases the supply of fuel to the carburetor. This gives a *richer* fuel/air mixture. Setting the needles midway between the lean and rich positions will usually give the best results.

Adjust the carburetor as follows:

1. With the engine stopped, turn the idle fuel adjusting needle **in** (clockwise) until it bottoms *lightly*.  
**NOTE:** The tip of the idle fuel and main fuel adjusting needles are tapered to critical dimensions. Damage to the needles and the seats in carburetor body will result if the needles are forced.
2. **Preliminary settings:** Turn the adjusting needles out (counterclockwise) from lightly bottomed. On the MV16/18 turn the idle needle 1-1/4 turns—the main needle 1-1/4 turns. On the MV20 turn the idle 1-1/4 turns, turn the main 1 turn.
3. Start the engine and run at half throttle for five to ten minutes to warm up. The engine must be warm before making final settings (Steps 4, 5, 6, and 7).
4. **Main Fuel Needle Setting:** *This adjustment is required only for **adjustable** main jet carburetors. If the carburetor is a fixed main jet type, go to step 5.*

Place the throttle into the “fast” position. If possible, place the engine under load.

Turn the main fuel adjusting needle **out** (counterclockwise) from the preliminary setting until the engine speed decreases (rich). Note the position of the needle.

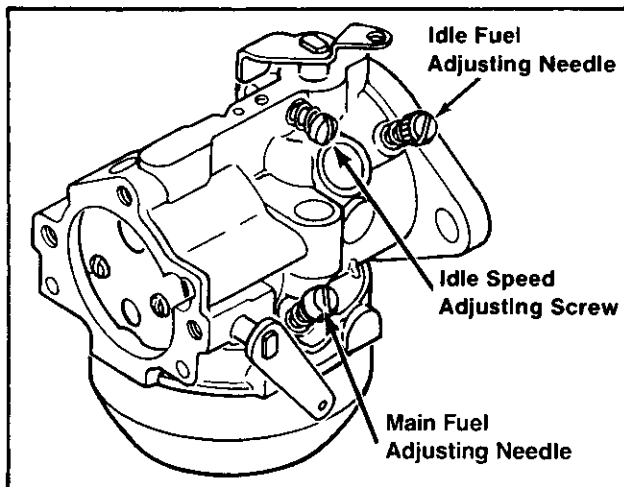

Figure 6-7. Fixed Main Jet Carburetor.

Now turn the adjusting needle **in** (clockwise). The engine speed may increase, then it will decrease as the needle is turned in (lean). Note the position of the needle.

Set the adjusting needle **midway** between the rich and lean settings. See Figure 6-8.

5. **Idle Speed Setting:** Place the throttle control into the “idle” or “slow” position. Set the idle speed to **1200 rpm\*** ( $\pm 75$  rpm) by turning the idle speed adjusting screw **in** or **out**. Check the speed using a tachometer.

\*NOTE: The actual idle speed depends on the application. Refer to the equipment manufacturer’s instructions for specific idle speed settings. The recommended idle speed for Basic Engines is 1200 rpm. To ensure best results when setting the idle fuel needle, the idle speed must not exceed 1500 rpm.

6. **Idle Fuel Needle Setting:** Place the throttle into the “idle” or “slow” position.

Turn the idle fuel adjusting needle **out** (counterclockwise) from the preliminary setting until the engine speed decreases (rich). Note the position of the needle.

Now turn the adjusting needle **in** (clockwise). The engine speed may increase, then it will decrease as the needle is turned in (lean). Note the position of the needle.

Set the adjusting needle **midway** between the rich and lean settings. See Figure 6-8.

7. Recheck the idle speed using a tachometer. Readjust the speed as necessary.

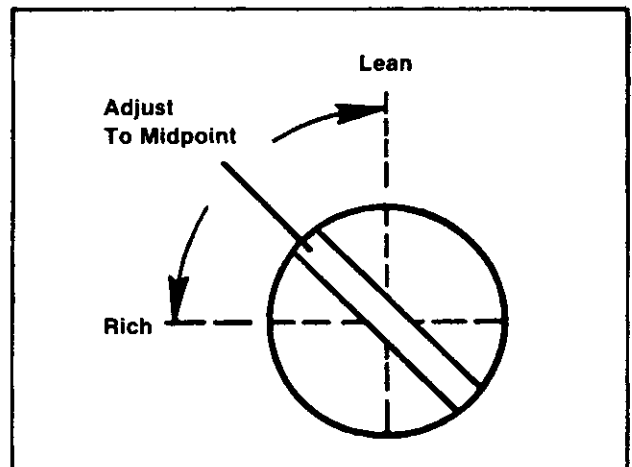

Figure 6-8. Optimum Idle Fuel Setting.

## Disassembly

Refer To Figures 6-6 and 6-9.

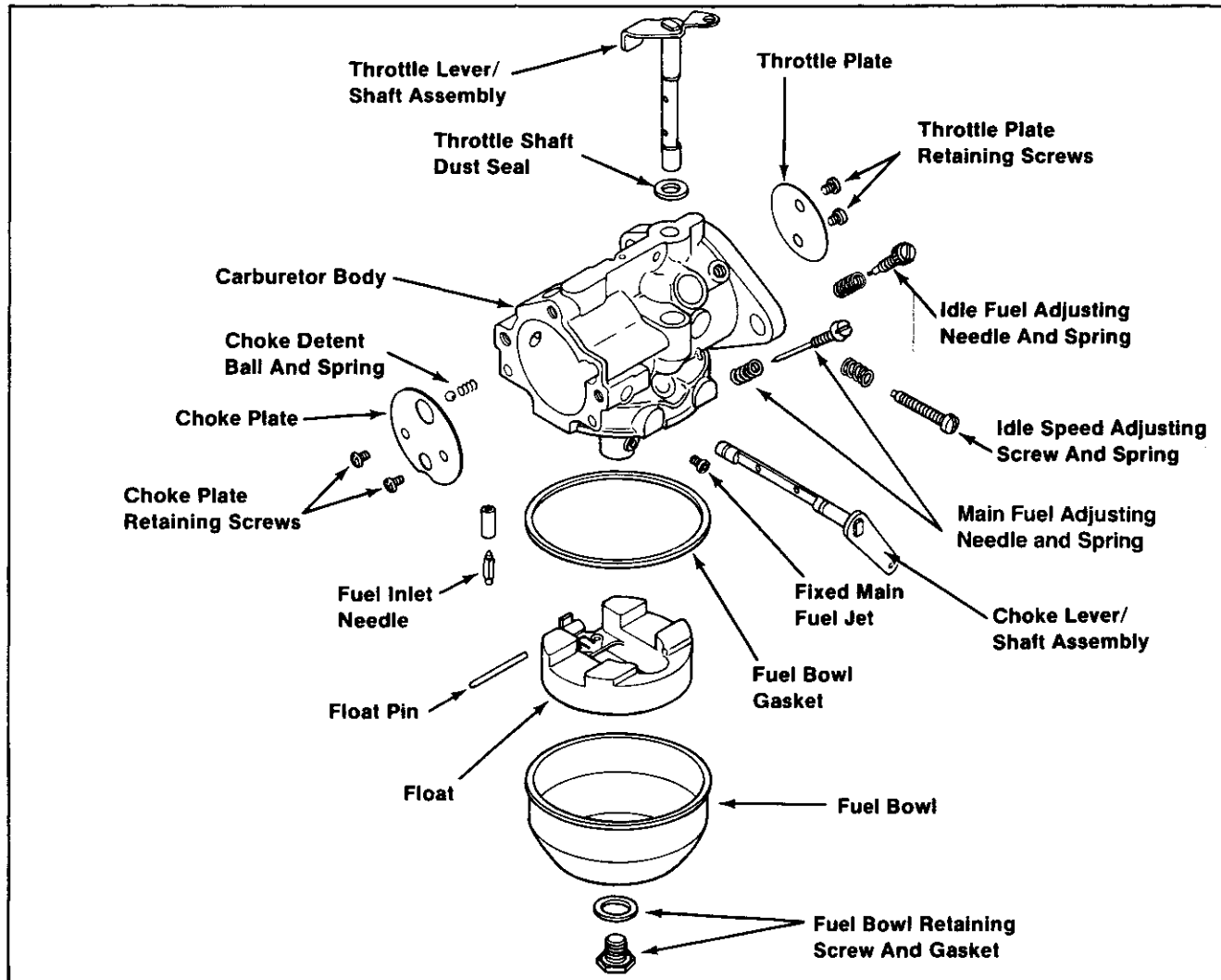

Figure 6-9. Fixed Main Jet Carburetor - Exploded View

1. Remove the bowl retaining screw, retaining screw gasket, and fuel bowl.
2. Remove the bowl gasket, float pin, float, and fuel inlet needle.  
**CAUTION:** To prevent damage to the carburetor, do not attempt to remove the fuel inlet seat as it is not serviceable. Replace the carburetor if the fuel inlet seat is damaged.
3. Remove the idle fuel adjusting needle and spring. Remove the idle speed adjusting screw and spring.
4. Remove the main fuel jet (FIXED JET) or main fuel adjusting screw and spring (ADJUSTABLE).
5. In order to clean the "off-idle" ports and the bowl vent channel thoroughly, the welch plugs covering these areas must be removed. Use tool No. KO1018 and the following procedure to remove the welch plugs. Refer to Figure 6-10.

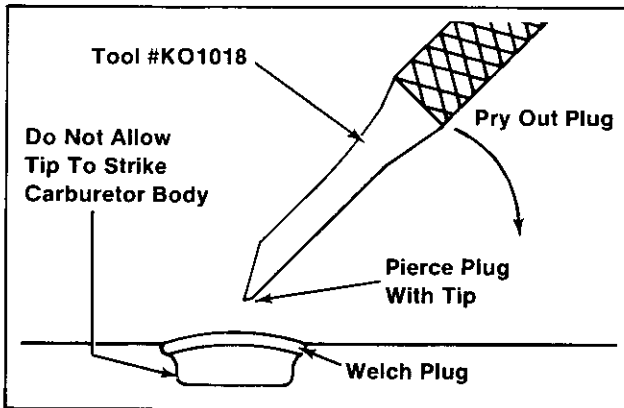

Figure 6-10. Removing Welch Plugs.

- A. Pierce the welch plug with the tip of the tool.

**CAUTION:** To prevent damage to the carburetor, do not allow the tool to strike the carburetor body.

- B. Pry out the welch plug using the tool.

#### Throttle And Choke Shaft Removal

Further disassembly to remove the throttle shaft and choke shaft is recommended only if these parts are to be cleaned or replaced.

#### Throttle Shaft Removal

1. Because the edges of throttle plate are beveled, mark the throttle plate and carburetor body with a marking pen to ensure correct reassembly (refer to Figure 6-11). Also take note of the throttle plate position in bore, and the position of the throttle lever.

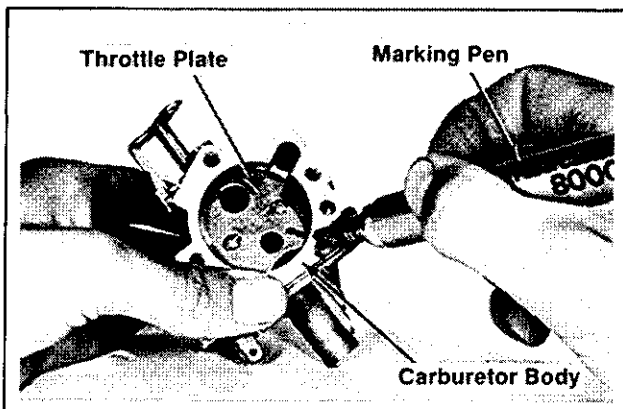

Figure 6-11. Marking Throttle Plate And Carburetor Body.

2. Carefully and slowly remove the screws securing the throttle plate to throttle shaft. Remove the throttle plate.
3. File off any burrs which may have been left on the throttle shaft when the screws were removed. Do this **before** removing the throttle shaft from carburetor body.
4. Remove the throttle lever/shaft assembly with foam dust seal from carburetor body.

#### Choke Shaft Removal

1. Because the edges of choke plate are beveled, mark the choke plate and carburetor body with a marking pen to ensure correct reassembly (refer to Figure 6-12). Also take note of the choke plate position in bore, and the position of the choke lever.

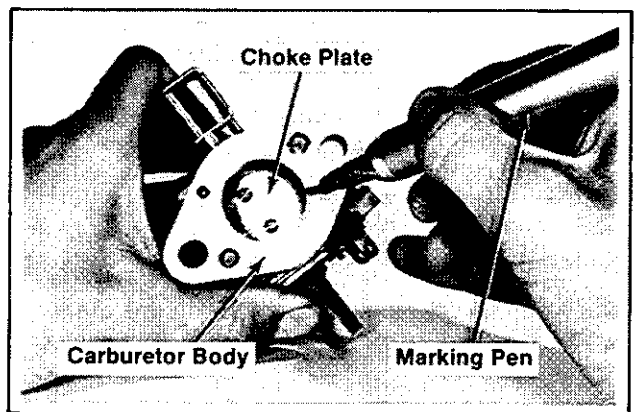

Figure 6-12. Marking Choke Plate And Carburetor Body.

2. Carefully and slowly remove the screws securing the choke plate to choke shaft. Remove the choke plate.
3. File off any burrs which may have been left on the choke shaft when the screws were removed. Do this **before** removing the choke shaft from carburetor body.
4. Rotate the choke shaft until the cutout portion of shaft is facing the air cleaner mounting surface (refer to Figure 6-13). Place the carburetor body on work bench with choke side down. Remove the choke lever/shaft assembly from carburetor body; the detent ball and spring will drop out.

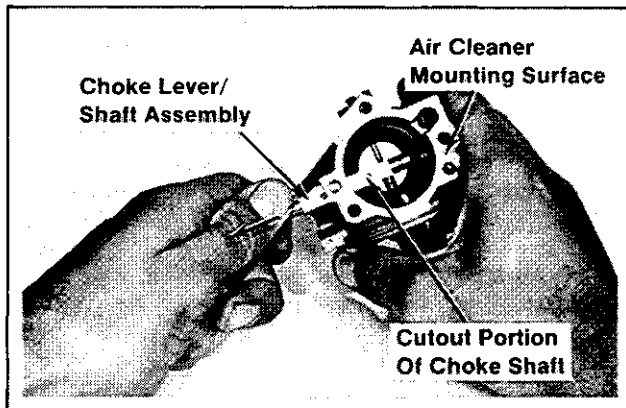

Figure 6-13. Removing Choke Lever/Shaft.

## Cleaning

### **WARNING: Flammable Solvents!**



Carburetor cleaners and solvents are extremely flammable. Keep sparks, flames, and other sources of ignition away from the area. Follow the cleaner manufacturer's warnings and instructions on its proper and safe use. Never use gasoline as a cleaning agent.

All parts should be carefully cleaned using a carburetor cleaner (such as acetone). Be sure all gum deposits are removed from the following areas:

- **Carburetor body and bore;** especially the areas where the throttle plate, choke plate, and shafts are seated.
- **Idle fuel and "off-idle" ports in carburetor bore, main jet, bowl vent, and fuel inlet seat.**

NOTE: These areas can be cleaned using a piece of fine wire in addition to cleaners. Be careful not to enlarge the ports, or break the cleaning wire within ports. Blow out all passages with compressed air.

- **Float and float hinge.**
- **Fuel Bowl.**
- **Throttle plate, choke plate, throttle shaft, and choke shaft.**

CAUTION: Do not submerge the carburetor in cleaner or solvents when fiber, rubber, or foam seals or gaskets, or the fuel inlet needle are installed. The cleaner may damage these parts.

## Inspection

Carefully inspect all components and replace those that are worn or damaged.

- Inspect the carburetor body for cracks, holes, and other wear or damage.
- Inspect the float for cracks or holes. Check the float hinge for wear, and missing or damaged float tabs.
- Inspect the fuel inlet needle for wear or grooves.
- Inspect the tip of the idle fuel adjusting needle for wear or grooves.
- Inspect the throttle and choke shaft and plate assemblies for wear or excessive play.

## Repair

Always use new gaskets when servicing and reinstalling carburetors. Repair kits are available which include new gaskets and other components. These kits are described below.

Components such as the throttle and choke shaft assemblies, throttle plate, choke plate, idle fuel needle, main jet, and others, are available separately.

Always refer to Parts Manual for the engine being serviced to ensure the correct carburetor repair kits and replacement parts are ordered.

### **Carburetor Repair Kit No. 25 757 08** (For WHG-Series Carbs.) Contains:

Qty.	Description
2*	Carburetor Mounting Gasket
3*	Air Cleaner Base Gasket
1	Bowl Gasket
1	Bowl Retaining Screw Gasket
1	Welch Plug, 3/8" Dia.
1	Welch Plug, 5/16" Dia.
1	Fuel Inlet Needle

\*Styles are different.

### **Float Assembly Kit No. 25 757 09** (For WHG-Series Carbs.) Contains:

Qty.	Description
1	Float Assembly
1	Float Pin

## Reassembly

(Refer to Figures 6-6 and 6-9.)

### Throttle Shaft Installation

1. Install the foam dust seal on throttle shaft. Insert the throttle lever/shaft assembly into carburetor body with the cutout portion of shaft facing the carburetor mounting flange.
2. Install the throttle plate to throttle shaft. Make sure the plate is positioned properly in bore as marked and noted during disassembly (the numbers stamped on plate should face the carburetor mounting flange). Apply Loctite® #609 to threads of 2 plate retaining screws. Install screws so they are slightly loose.
3. Apply finger pressure to the throttle lever/shaft to keep it firmly seated against pivot in carburetor body. Rotate the throttle shaft until the throttle plate fully closes the bore around its entire perimeter; then tighten screws. Refer to Figure 6-14.

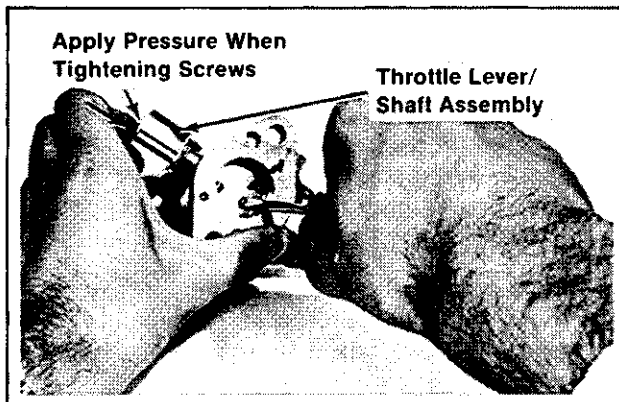

Figure 6-14. Installing Throttle Lever/Shaft.

4. Operate the throttle lever; check for binding between the throttle plate and carburetor bore. Loosen screws and adjust throttle plate as necessary; then torque screws to **8/12 in. lb.**

### Choke Shaft Installation

1. Install the detent spring and ball into the carburetor body.

**CAUTION:** If the detent ball does not drop through the tapped air cleaner base screw hole by its own weight, do not force it. Forcing the ball could permanently lodge it in the hole.

Install the ball through the choke shaft bore instead.

2. Compress the detent ball and spring. Insert the choke lever/shaft assembly into carburetor body with the cutout portion of shaft facing the air cleaner mounting surface (refer to Figure 6-15). Make sure the choke lever is on the correct side of carburetor body.

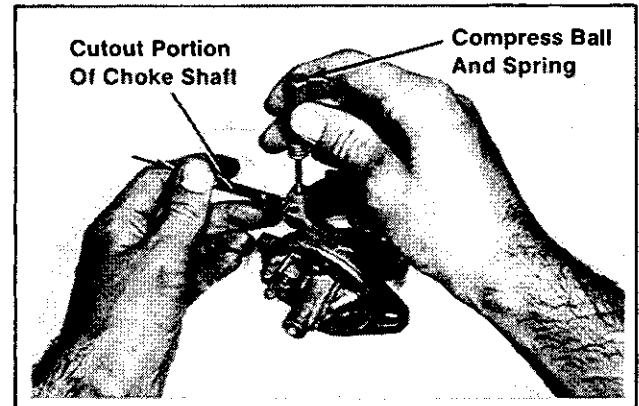

Figure 6-15. Installing Choke Lever/Shaft

3. Install the choke plate to choke shaft. Make sure the plate is positioned properly in bore as marked and noted during disassembly. (The numbers stamped on plate should face the air cleaner mounting surface and be upright.) Apply Loctite® #609 to threads of 2 plate retaining screws. Install the screws so they are slightly loose.
4. Operate the choke lever; check for binding between the choke plate and carburetor bore. Adjust plate as necessary; then torque screws to **8/12 in. lb.**

### Carburetor Reassembly

1. If the welch plugs have been removed for cleaning, new welch plugs must be installed. Use tool No. KO1017 and the following procedure to install the welch plugs.
  - A. Position the carburetor body securely with the welch plug cavities to the top.
  - B. Place a new welch plug into the cavity with the raised portion up. Use the end of the tool that is about the same size as plug and **flatten** the plug. Do not force the plug below the top surface. Refer to Figure 6-16.



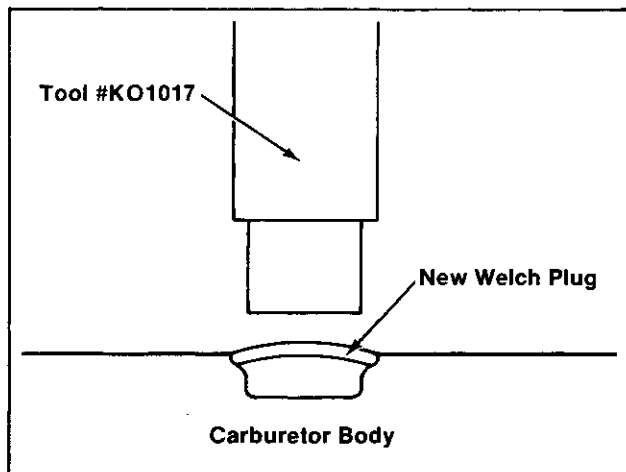

Figure 6-16. Installing Welch Plugs.

C. After welch plugs are installed, seal the exposed surface with glyptal (or an equivalent sealant). Allow the sealant to dry.

NOTE: If a commercial sealant is not available, fingernail polish can be used.

2. Install the main fuel jet and torque to **12/16 in. lb.**
3. Install fuel inlet needle into inlet seat. Install float and slide float pin through float hinge and float hinge towers on carburetor body.
4. **Set Float Level:** Invert the carburetor so the float tab rests on the fuel inlet needle. The exposed surface of float should be **parallel** with the bowl gasket surface of the carburetor body (exposed, free end of float .690"-.720" from bowl gasket surface). Refer to Figure 13.

Bend the float tab with a small screw driver to adjust.

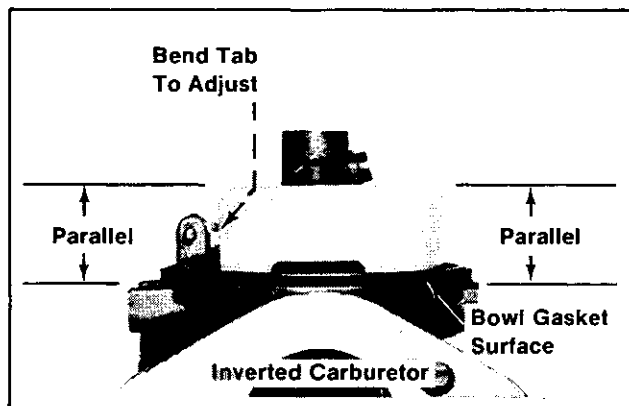

Figure 6-17. Setting Float Level.

5. Install a new bowl gasket and the fuel bowl. Make sure the bowl gasket and bowl are centered and positioned properly to ensure a good seal.
6. Install a new bowl retaining screw gasket and the bowl retaining screw. Torque screw to **45/55 in. lb.**
7. Install the idle speed adjusting screw and spring.
8. Install the idle fuel adjusting needle and spring. Turn the adjusting needle **in** (clockwise) until it bottoms **lightly**.
9. Turn the idle fuel needle **out** (counterclockwise) from lightly bottomed according to the instructions in the "Adjustment" portion of this section.
10. Install the main fuel adjusting needle and spring. Turn the adjusting needle **in** (clockwise) until it bottoms **lightly**.
11. Turn the main fuel needle **out** (counterclockwise) from lightly bottomed according to the instructions in the "Adjustment" portion of this section.

## High Altitude Operation

When operating the engine at high altitudes, the main fuel mixture tends to get overrich. An overrich mixture can cause conditions such as black, sooty exhaust smoke, misfiring, loss of speed and power, poor fuel economy, and poor or slow governor response.

To compensate for the effects of high altitude, a special high altitude main fuel jet is available. For MV16 and MV18 engines, it should be installed when operating at altitudes of **6,000 ft.** and above. The high altitude jet is sold in kit **No. 52 755 74** which includes the jet and necessary gaskets.

## High Altitude Jet Installation

1. Remove the fuel bowl retaining screw, retaining screw gasket, fuel bowl, and bowl gasket.  
  
NOTE: If necessary, remove the air cleaner and carburetor from engine to make fuel bowl removal easier.
2. Remove the float pin, float, and fuel inlet needle.
3. Remove the existing main fuel jet.
4. Install the new high altitude main fuel jet and torque to **12/16 in. lb.**
5. Reinstall the fuel inlet needle, float, and float pin.

6. Install the new bowl gasket from kit and the fuel bowl. Make sure the bowl gasket and bowl are centered and positioned properly to ensure a good seal.
7. Install the new bowl retaining screw gasket from kit and the bowl retaining screw. Torque screw to **45/55 in. lb.**
8. Reinstall the carburetor and air cleaner to engine as necessary using the new gaskets from kit.

## GOVERNOR

Magnum engines are equipped with a centrifugal flyweight mechanical governor. It is designed to hold the engine speed constant under changing load conditions. The governor gear/flyweight mechanism is mounted within the crankcase and is driven off the gear on the camshaft. Refer to Figure 6-18.

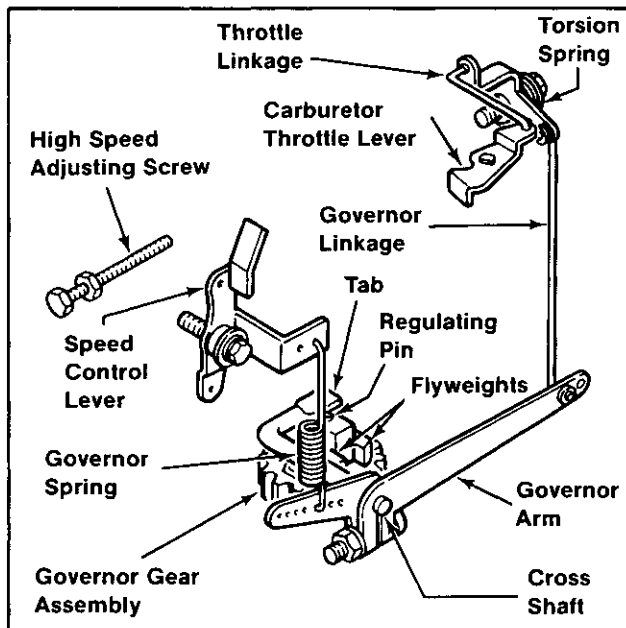

Figure 6-18. Centrifugal Flyweight Mechanical Governor.

## Operation

Centrifugal force acting on the rotating governor gear assembly causes the flyweights to move outward as speed increases and inward as speed decreases. As the flyweights move outward they force the regulating pin of the assembly to move outward. The regulating pin contacts the tab on the cross shaft, causing the shaft to rotate with changing speed. One end of the cross shaft protrudes through the side of the crankcase.

Through external linkage attached to the cross shaft, the rotating action is transmitted to the throttle plate of carburetor.

When the engine is at rest and the throttle is in the "fast" position, the tension of the governor spring holds the throttle valve open. When the engine is operating (governor gear assembly is rotating), the force applied by the regulating pin against the cross shaft tends to close the throttle valve. The governor spring tension and the force applied by the regulating pin are in "equilibrium" during operation, holding the engine speed constant.

When a load is applied and the engine speed (and governor speed) decreases, the governor spring tension moves the governor arm to open the throttle plate wider. This admits more fuel and restores engine speed. (This action takes place very rapidly, so a reduction in speed is hardly noticed.) As the speed reaches the governed setting, the governor spring tension and the force applied by the regulating pin will again be in equilibrium. This maintains engine speed at a relatively constant level.

Governed speed is variable as determined by a throttle control lever.

## Adjustment

### **WARNING: Overspeed Is Hazardous!**



The maximum allowable speed for these engines is 3750 RPM, no load. Never tamper with the governor settings to increase the maximum speed. Severe personal injury and damage to the engine or equipment can result if operated at speeds above maximum.

## INITIAL ADJUSTMENT

Make this initial adjustment whenever the governor arm is loosened or removed from the cross shaft. To ensure proper setting, make sure the governor linkage is connected to governor arm and the throttle lever on intake manifold. Make sure the throttle linkage is connected to the throttle lever on intake manifold and the throttle lever on carburetor. Refer to Figures 6-18 and 6-19.

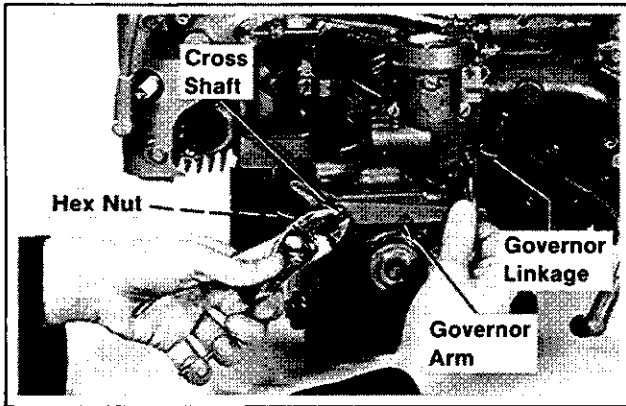

Figure 6-19. Initial Governor Adjustment.

1. Pull the governor arm down and away from the carburetor as far as it will go. Refer to Figure 6-19.
2. Grasp the end of cross shaft with pliers and turn clockwise as far as it will go.
3. Tighten the hex nut on governor arm to **15 in. lb.** torque.

### HIGH SPEED ADJUSTMENT

The maximum allowable speed is 3750 RPM, no load. The actual high speed setting depends on the application. Refer to the equipment manufacturer's instructions for specific high speed settings. Check the operating speed with a tachometer; do not exceed the maximum.

#### To adjust the high speed stop:

1. Loosen the lock nut on the high speed screws. Refer to Figure 6-20.

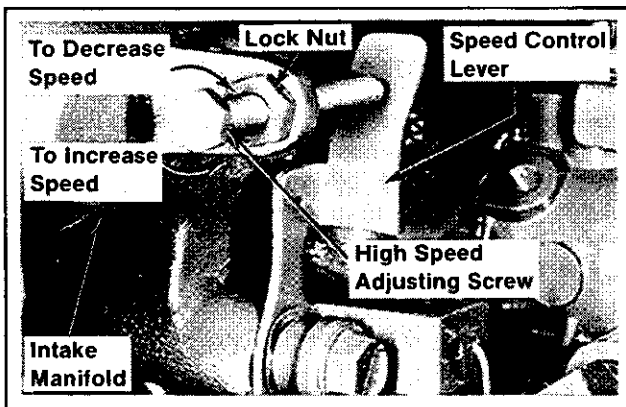

Figure 6-20. High Speed Adjustment.

2. Turn the adjusting screw in or out until the desired speed is reached. Tighten the lock nut securely.
3. Recheck the speed the tachometer; readjust if necessary.

### SENSITIVITY ADJUSTMENT

Governor sensitivity is adjusted by repositioning the governor spring in the holes in governor arm. If set too sensitive, speed surging will occur with a change in load. If a big drop in speed occurs when normal load is applied, the governor should be set for greater sensitivity.

The standard spring position is in the **third** hole from cross shaft in **governor arm**, and in the **second** hole from pivot in **speed control lever**. The positions can vary, depending on the engine application. Therefore, make a note of (or mark) the spring positions before removing it from the governor arm and speed control lever. Refer to Figure 6-21.

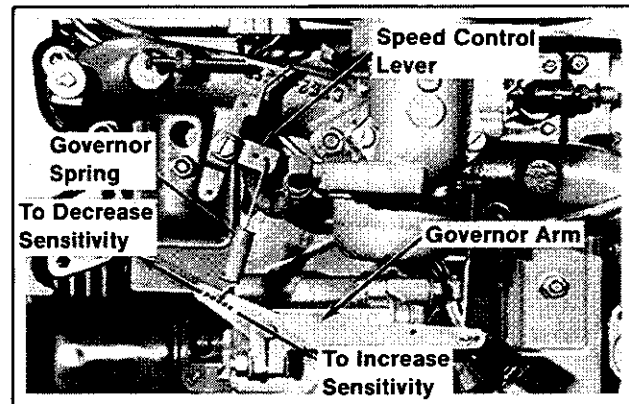

Figure 6-21. Governor Sensitivity Adjustment.

**To increase sensitivity**, increase the governor spring tension by moving the spring in governor arm towards the cross shaft.

**To decrease sensitivity, and allow broader control**, decrease spring tension by moving the spring in governor arm away from the cross shaft.

# SECTION 7 LUBRICATION SYSTEM

## OPERATION

Magnum vertical shaft engines use a full-pressure lubrication system that delivers oil to the crankshaft, camshaft, and connecting rod journal surfaces. Under normal engine operating conditions, the oil pressure can be as high as 50 psi. A high-efficiency gerotor oil pump

maintains high oil flow and oil pressure, even at low speeds and high operating temperatures. A pressure relief valve, located in the engine crankcase behind the oil pan, limits the maximum oil pressure in the system. No adjustments to the relief valve are possible. Refer to Figure 7-1.

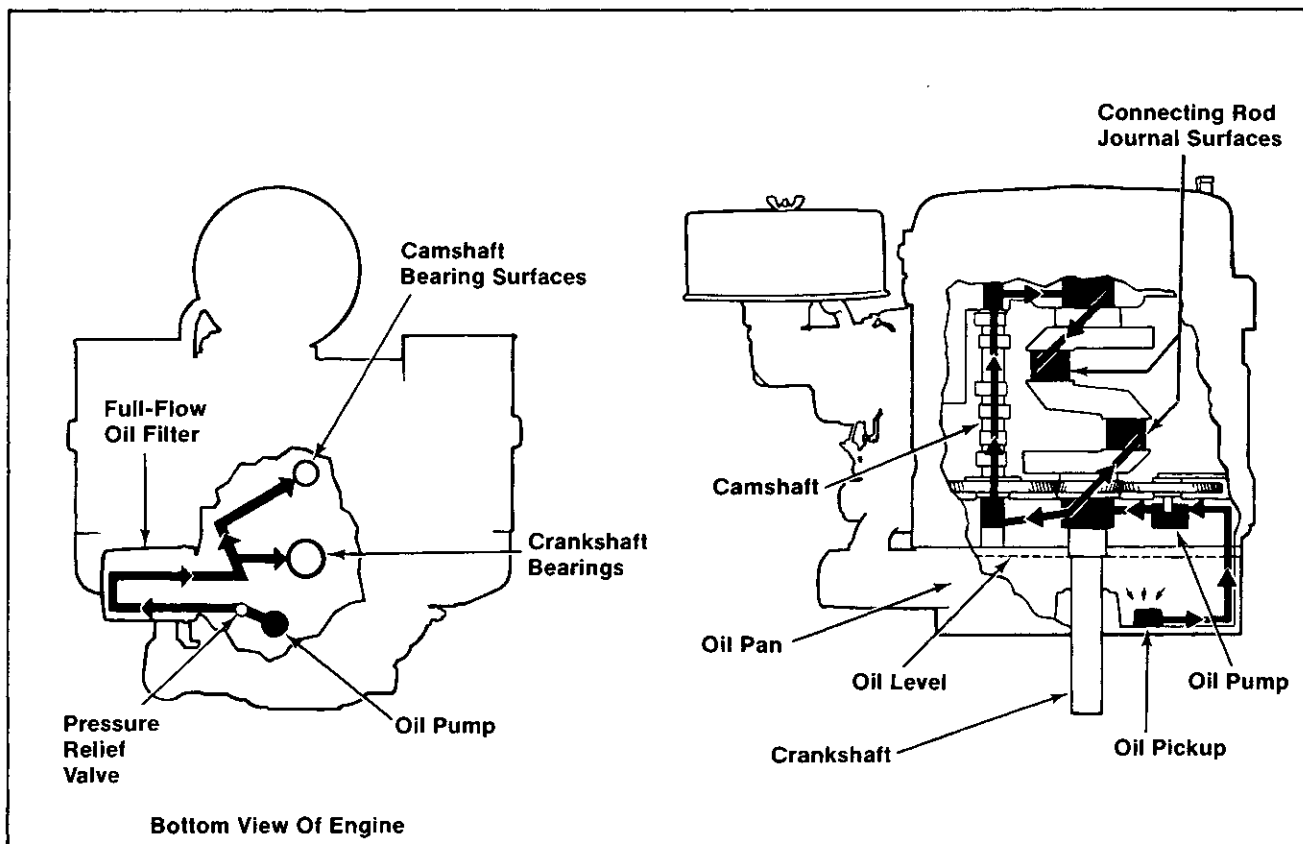

Figure 7-1. Full-Pressure Lubrication System.

## LUBRICATION SYSTEM SERVICE

The oil pump cover and rotors, pressure-relief valve, and oil pickup can be serviced without splitting the crankcase. Remove the oil pan to service those parts.

The crankcase must be split to service the pump shaft and drive gear.

Refer to Figures 7-2, 7-3, and 7-4. Also refer to the "Disassembly" and "Reassembly" sections for complete oil pump component removal and installation procedures.

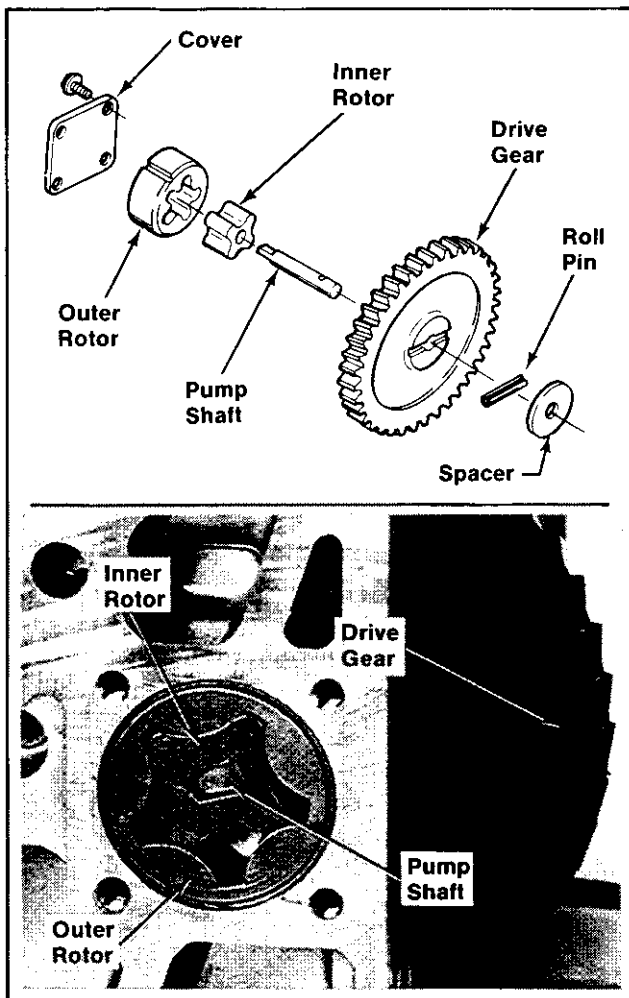

Figure 7-2. Oil Pump Assembly.

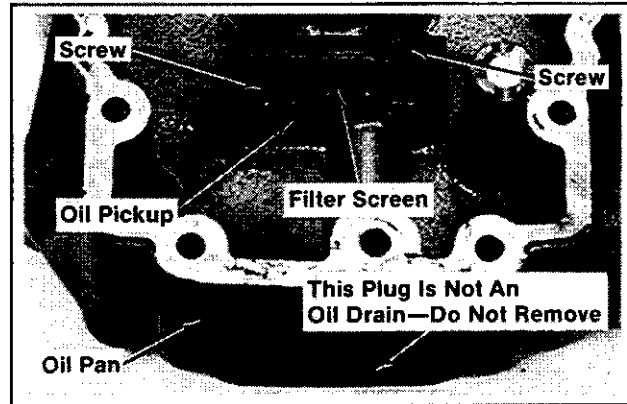

Figure 7-3. Oil Pickup.

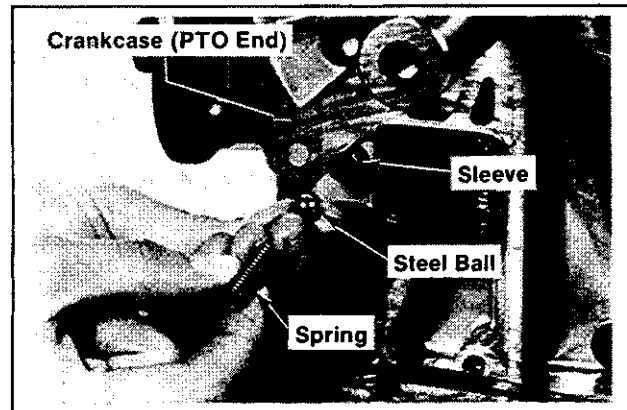

Figure 7-4. Oil Pressure Relief Valve.

## OIL FILTER

All basic engines are equipped with a full-flow oil filter. The filter helps remove sludge and other combustion by-products from the oil, extends the oil change interval, and helps cool the oil.

Oil filters are optional for special spec engines and are available in engine-mounted or remote-mounted types. A cover plate seals the crankcase on those engines not equipped with an oil filter. Refer to Figures 7-5, 7-6, 7-7, and 7-8.

For oil and oil filter change instructions, refer to the "Periodic Maintenance" section.

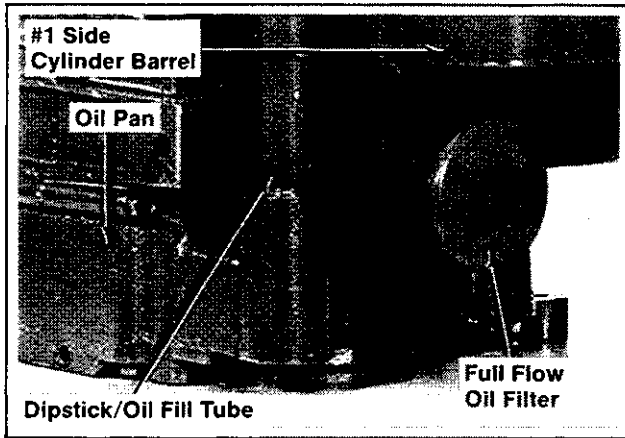

Figure 7-5. Engine Mounted Oil Filter.

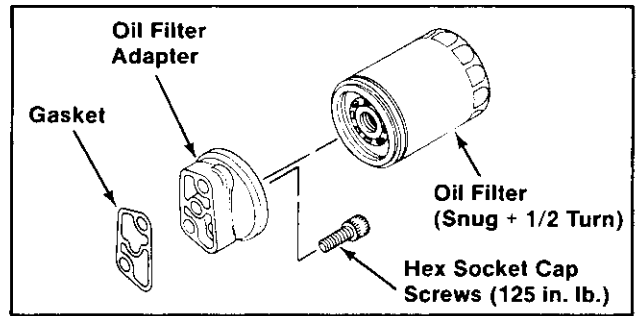

Figure 7-6. Installation Torques—Engine Mounted Oil Filter.

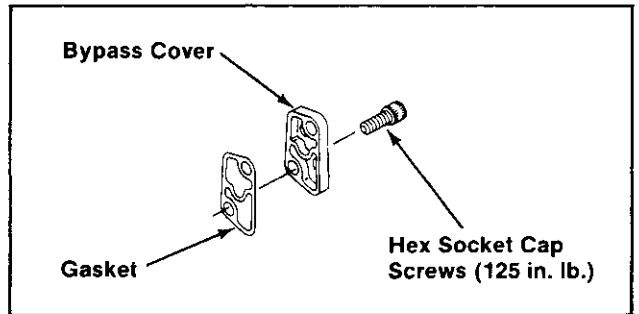

Figure 7-7. Installation Torque—Filter Bypass Cover (Engines Without Oil Filter).

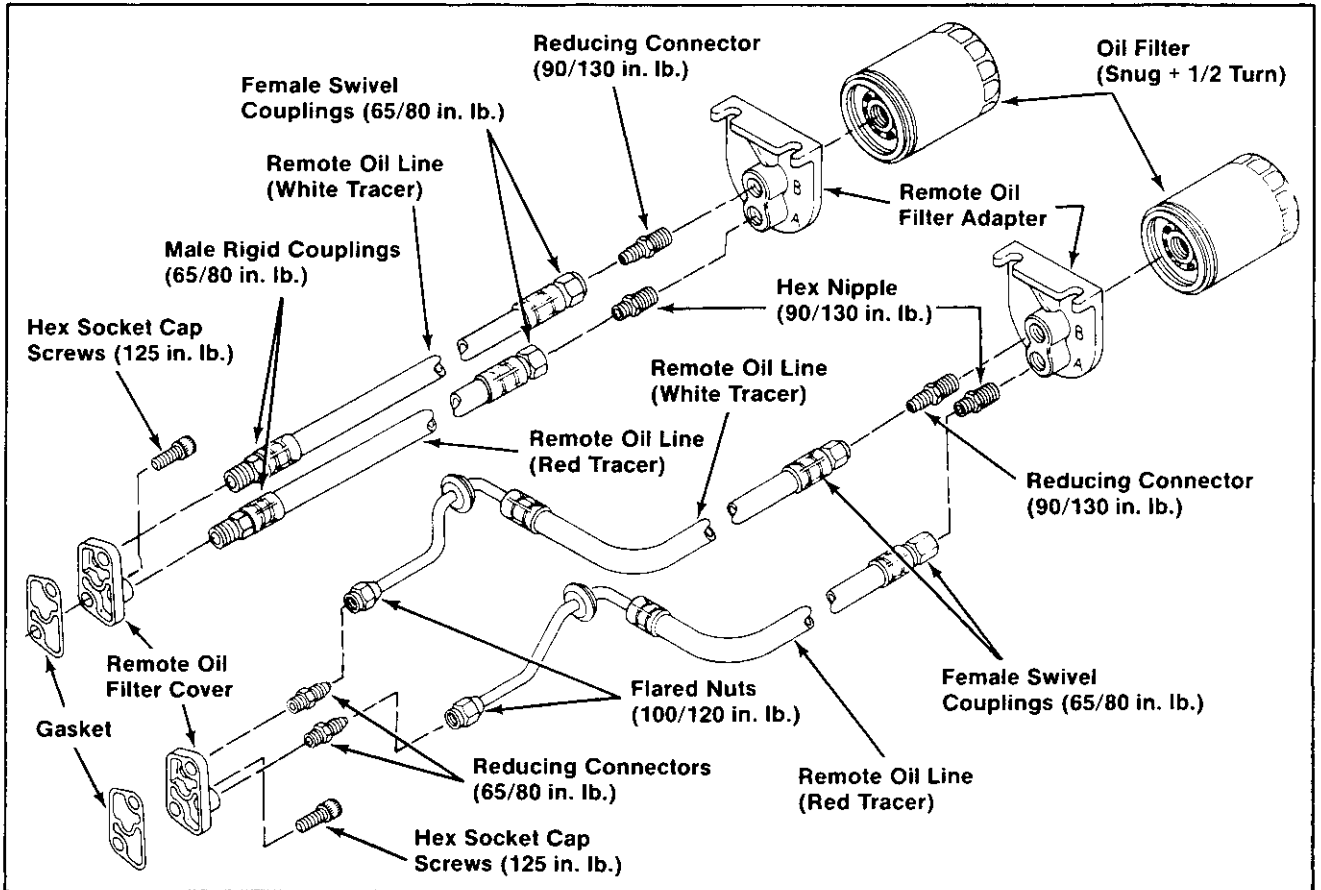

Figure 7-8. Installation Torques—Remote Mounted Oil Filters.

## OPTIONAL OIL SENTRY™ OIL PRESSURE MONITOR



Some engines are equipped with the optional Oil Sentry oil pressure monitor. Oil Sentry will either stop the engine or activate a "low oil" warning light, if the oil pressure gets low. Actual Oil Sentry use will depend on the engine application.

### Operation

Oil Sentry uses a pressure switch in one of the main crankcase oil galleries to detect low oil pressure. At oil pressures below approximately 3-1/2 psi, the pressure switch closes. At oil pressures above approximately 3-1/2 psi the pressure switch opens.

On stationary or unattended applications (pumps, generators, etc.), the pressure switch can be used to ground the ignition module to stop the engine.

On vehicular applications (garden tractors, mowers, etc.), the pressure switch can be used to activate a "low oil" warning light.

**CAUTION:** Oil Sentry is not a substitute for checking oil level **BEFORE EACH USE**. Make sure the oil level is maintained up to the "F" mark on dipstick.

### Installation

The pressure switch can be installed in one of two locations. One location uses the gallery in the raised boss located on the #1 crankcase side, below the cylinder barrel (refer to Figure 7-9). On engines not using this location for the Oil Sentry switch, the oil gallery is sealed with 1/16" NPTF pipe plug. The other location uses an optional, specially-machined oil filter adapter (refer to Figure 7-10). In general, the type of muffler or exhaust system used will determine which location is used.

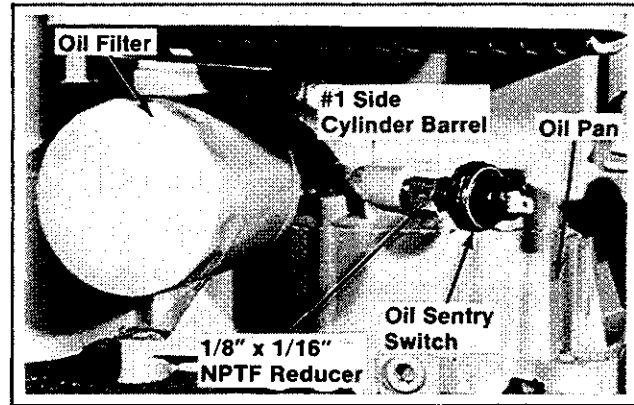

Figure 7-9. Crankcase Mounted Oil Sentry Switch.

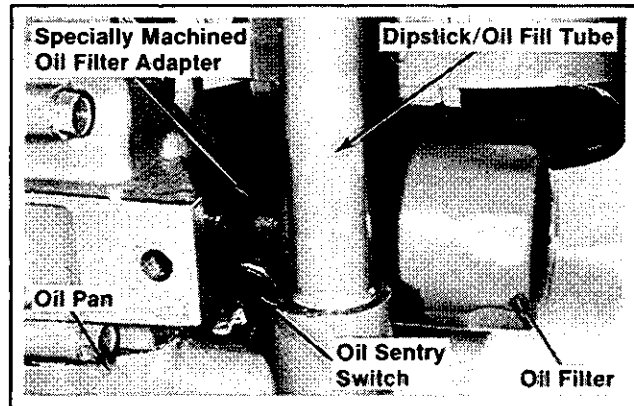

Figure 7-10. Oil Filter Adapter Mounted Oil Sentry Switch.

On engines (such as Basic specs) equipped with the dual, oval-shaped mufflers, the Oil Sentry switch must be installed in the special oil filter adapter. The clearance between the mufflers and the crankcase is not sufficient to permit installing the switch in the crankcase boss.

On engines equipped with other types of mufflers or exhaust pipes, the Oil Sentry switch could be installed in the crankcase boss, provided there is sufficient clearance.

#### To Install Oil Sentry Switch To Crankcase Boss

1. Remove the 1/16" NPTF pipe plug (or old switch and 1/8" x 1/16" NPTF reducer) from crankcase.
2. Apply Loctite® #592 Teflon sealant (or equivalent) to threads of switch. Install reducer to switch and tighten securely.
3. Apply Loctite® #592 Teflon sealant (or equivalent) to threads of reducer. Install reducer/switch assembly into crankcase. Tighten the **reducer** securely into the crankcase.

---

### **To Install Oil Sentry Switch To Special Oil Filter Adapter**

The optional, specially-machined oil filter adapter has a 1/8" NPTF tapped hole. The switch is installed directly into the adapter; the 1/8" x 1/16" NPTF reducer is **not** required.

1. Apply Loctite® #592 Teflon sealant (or equivalent) to threads of switch.
2. Install the switch into the tapped hole in oil filter adapter and tighten securely.

### **Testing**

The pressure switch is a normally closed type, calibrated to open (break contact) with increasing pressure, and close (make contact) with decreasing pressure within the range of 2.0/5.0 psi.

Compressed air, a pressure regulator, a pressure gauge, and a continuity tester are required to test the switch.

1. Connect the continuity tester across the blade terminal and metal case of switch. With 0-psi pressure applied to switch, the tester should indicate continuity (switch closed).
2. Gradually increase the pressure to the switch. The tester should indicate a change to no continuity (switch open) as the pressure increases through the range of 2.0/5.0-psi. The switch should remain open as pressure is increased to 90-psi maximum.
3. Gradually decrease the pressure to the switch. The tester should indicate a change to continuity (switch closed) as the pressure decreases through the range of 2.0/5.0-psi, approaching 0-psi.



# SECTION 8 ELECTRICAL SYSTEMS AND COMPONENTS

## MAGNUM ELECTRONIC MAGNETO IGNITION SYSTEM

Magnum vertical shaft engines are equipped with a state-of-the-art electronic magneto ignition system. The system consists of the following components (refer to Figure 8-1):

- A magnet assembly, which is PERMANENTLY affixed to the flywheel.
- An electronic magneto ignition module, which is mounted to the #1 side cylinder barrel. This module is damage-protected with an **internal diode**, in the event 12 volts D.C. is applied to the kill terminal.
- A kill switch (or keyswitch) which stops the engine by grounding the ignition module.

### Operation

As the flywheel rotates and the magnet assembly moves past the ignition module, a low voltage is induced in the primary windings of the module.

When the primary voltage is precisely at its peak, the module induces a high voltage in its secondary windings. This high voltage creates a spark at the tip of the spark plugs, igniting the fuel-air mixture in the combustion chambers. The timing of the spark is automatically controlled by the module. Therefore, no ignition timing adjustments are required with this system.

**CAUTION:** Do not connect 12 volts to the ignition system or to any wire connected to the ignition module.

The ignition system operates independently of the battery, starting, charging, and other auxiliary electrical systems. Connecting 12 volts to the ignition module can cause the module to burn out. This type of damage is not covered by the engine warranty.

A break-before-make type keyswitch is required to prevent damage to the ignition module.

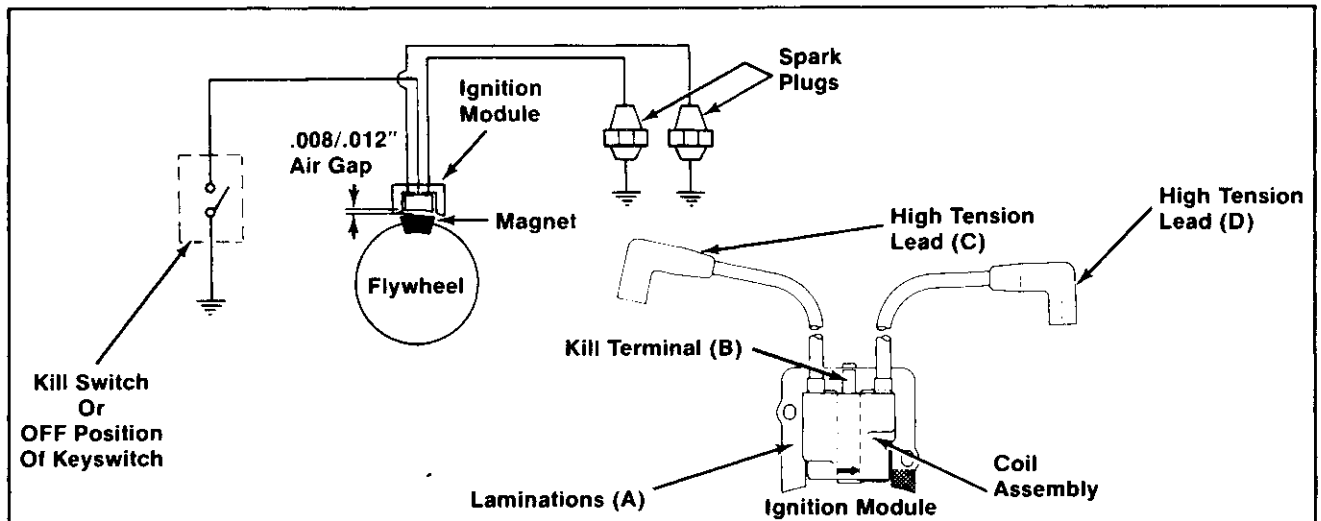

Figure 8-1. Magnum Electronic Magneto Ignition System.

## Ignition System Troubleshooting Guide

The following guide will help locate and correct ignition system-related starting problems. This procedure uses a simple tester which can be easily made by the serviceman. Refer to the "Special

Tools" section for ignition system tester construction details.

NOTE: Use a low voltage ohmmeter when ohmmeter is required. Always zero ohmmeter on each scale before testing to ensure accurate readings.

Problem	Test	Conclusion			
<b>ENGINE WILL NOT START</b>	1. Make sure spark plug leads are connected to spark plugs.				
	2. Check condition of spark plugs. Make sure gaps are set to .025".	If plugs are in good condition, check/adjust gaps and reinstall.			
	3. Check ignition module using test plugs (refer to the "Special Tools" section and Figure 8-2.) <ul style="list-style-type: none"> <li>a. Remove the high-tension leads from the engine spark plugs, and connect them to the test plugs.</li> </ul> <p style="margin-left: 20px;">NOTE: To maintain engine speeds normally obtained during cranking, do not remove the engine spark plugs.</p> <ul style="list-style-type: none"> <li>b. Make sure the engine ignition switch (kill switch) and/or keyswitch are in the "run" position.</li> <li>c. Crank the engine and observe the test plugs. Visible and audible sparks should be produced.</li> </ul>	If visible and audible sparks ARE produced, the ignition module is OK.  If visible and audible sparks ARE NOT produced: <ul style="list-style-type: none"> <li>a. Make sure engine ignition switch and/or keyswitch are in the "run" position.</li> <li>b. Check wires and terminals of ignition module and other components for accidental grounding and/or damaged insulation.</li> <li>c. If wires and terminals are OK, the ignition module is probably faulty and should be replaced. Test module further using an ohmmeter (Test 4).</li> </ul>			
	4a. Measure the primary resistance of module using an ohmmeter (refer to figures 8-1 and 8-3): <p style="margin-left: 20px;">Connect negative (-) lead of ohmmeter to kill terminal (B); connect positive (+) lead of ohmmeter to laminations (A). With the ohmmeter leads connected in this manner, the primary resistance should be <b>5 to 1000 ohms*</b>.</p> <p style="margin-left: 20px;">Reverse the ohmmeter leads. Connect the negative (-) lead to laminations (A); connect the positive (+) lead to kill terminal (B). With the ohmmeter leads connected in this manner, the primary resistance should be <b>30,000 ohms minimum</b>.</p> <p style="margin-left: 20px;">*NOTE: Resistance may vary, depending on voltage imposed by ohmmeter.</p>	If resistance is low or 0 ohms in both directions, module primary is shorted. Replace module.  If resistance is high or infinity ohms in both directions, module primary is open. Check keyswitch/wiring for shorts or connections which could apply 12V to kill terminal B. Correct those conditions, then replace module.  If resistance is within range, module primary is OK. Test secondary (Test 4b).			
4b. Measure the secondary resistance of module using an ohmmeter. Refer to Figures 8-1 and 8-4. <table style="margin-left: auto; margin-right: auto; border: none;"> <tr> <td style="text-align: center;"><b>Secondary Leads/Terminals</b></td> <td style="text-align: center;"><b>Secondary Resistance</b></td> </tr> <tr> <td style="text-align: center;">C - D</td> <td style="text-align: center;">22,000/42,000 ohms</td> </tr> </table>	<b>Secondary Leads/Terminals</b>	<b>Secondary Resistance</b>	C - D	22,000/42,000 ohms	If resistance is within range, module secondary is OK.  If resistance is low or 0 ohms, module secondary is shorted. Replace module.  If resistance is high or infinity ohms, module secondary is open. Replace module.
<b>Secondary Leads/Terminals</b>	<b>Secondary Resistance</b>				
C - D	22,000/42,000 ohms				

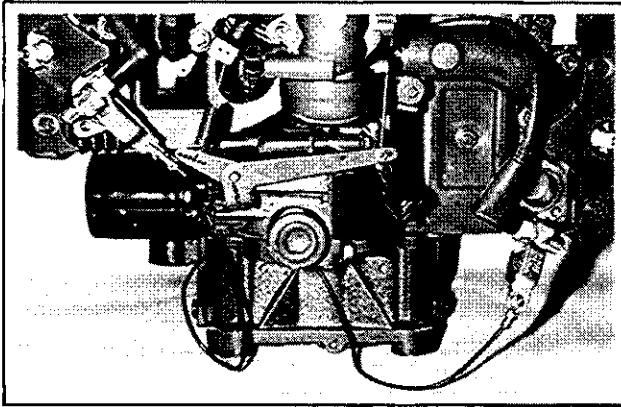

Figure 8-2. Ignition System Tester.

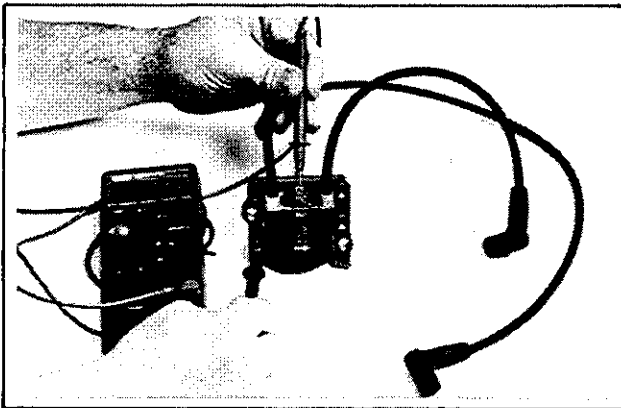

Figure 8-3. Testing Module Primary.

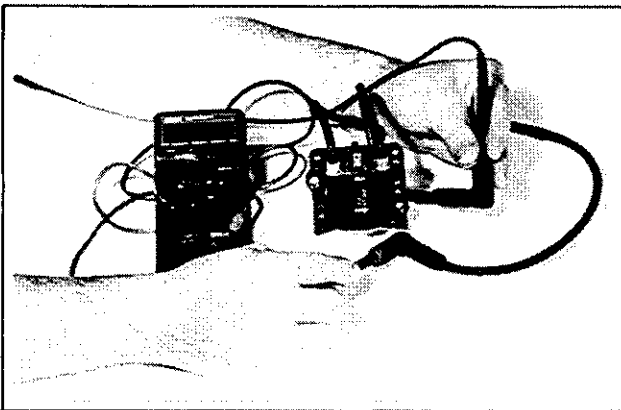

Figure 8-4. Testing Module Secondary.

## Ignition Module

### REMOVAL

1. Remove the blower housing.
2. Remove the kill lead from kill terminal of module. Refer to Figure 8-5.

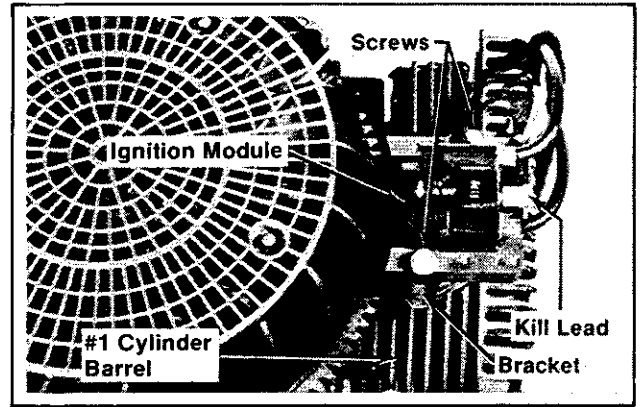

Figure 8-5. Removing Ignition Module.

3. Remove the hex flange screws and module from bracket on #1 cylinder barrel.

### INSTALLATION

1. Install the module and hex flange screws to bracket. Move the module as far from flywheel/magnet as possible—tighten the hex flange screws slightly.
2. Insert a .014" flat feeler gauge (or shim stock) between the magnet and module. Refer to Figure 8-6.

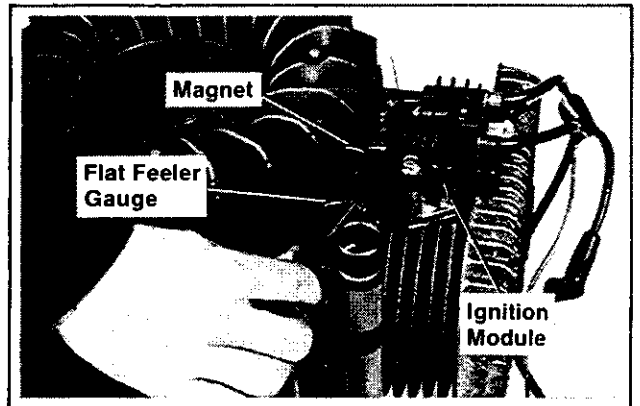

Figure 8-6. Setting Magnet-To-Module Air Gap.

3. Loosen the hex flange screw so the magnet pulls module against feeler gauge. Tighten the hex flange screw securely.
4. Remove the feeler gauge or shim stock. Due to the pull of the magnet, the bracket and hardware will flex slightly. The magnet-to-module air gap should be within the range of .008/.012".

5. Rotate the flywheel back and forth; check to make sure the magnet does not strike the module. Check gap with feeler gauge and readjust if necessary.
6. Install the kill lead to kill terminal of module. Reinstall the blower housing.

## Spark Plugs

Engine misfire or starting problems are often caused by spark plugs in poor condition or with improper gap setting.

### SERVICE

Every 100 operating hours remove the spark plugs, check condition, and reset gaps or replace with new plugs as necessary. Refer to Figure 8-7.

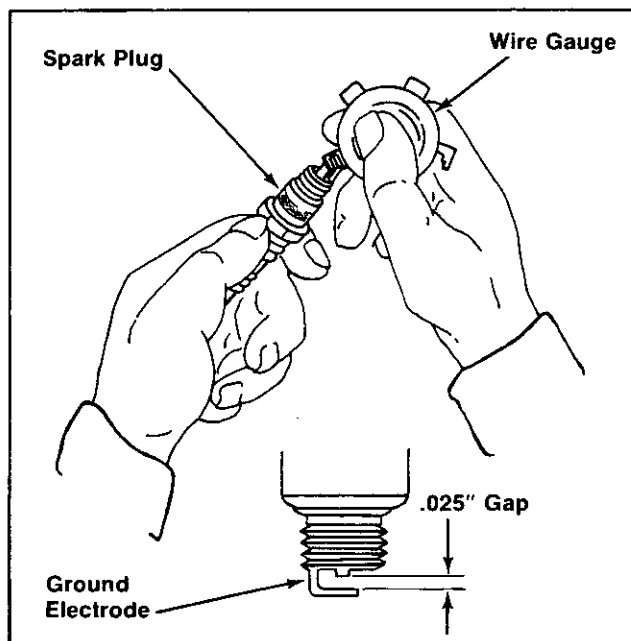

Figure 8-7. Servicing Spark Plug.

1. Before removing the spark plugs, clean the area around the base of plugs to keep dirt and debris out of the engine.
2. Remove the plugs and check condition. Replace the plugs if worn or if reuse is questionable.

Use Champion® type RV15YC (or equivalent) spark plugs.

**CAUTION:** Do not clean the spark plugs in a machine using abrasive grit. Some grit could remain in spark plugs and enter the engine causing extensive wear and damage.

3. Check the gaps using a wire feeler gauge. Adjust gaps to **0.025"** by carefully bending the ground electrode.
4. Reinstall the spark plugs into cylinder heads. Torque plugs to **10/15 ft. lb.**

### INSPECTION

Inspect the spark plugs as soon as they are removed from the cylinder heads. The deposits on the tips are an indication of the general condition of the piston rings, valves, and carburetor.

Normal and faulty spark plugs are shown in the following photos.

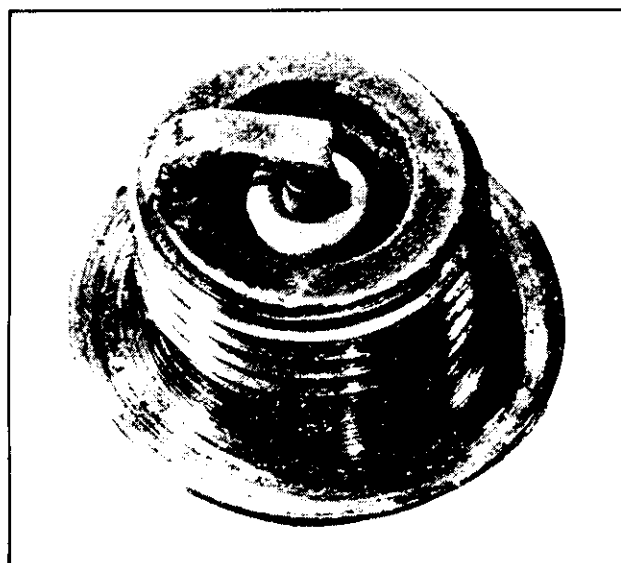

**Normal:** A plug taken from an engine operating under normal conditions will have light tan or gray colored deposits. If the center electrode is not worn, a plug in this condition could be regapped and reused.

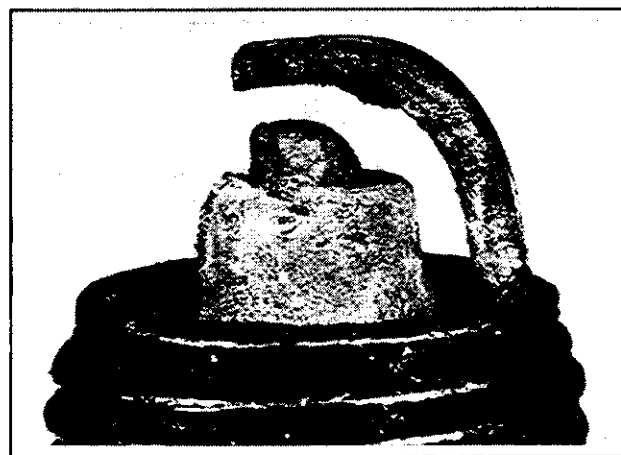

**Worn:** On a worn plug, the center electrode will be rounded and the gap will be eroded .010" or more than the correct gap. Replace a worn spark plug immediately.



**Carbon Fouled:** Soft, sooty, black deposits indicate incomplete combustion. Incomplete combustion is usually caused by overrich carburetion, weak ignition, or poor compression.

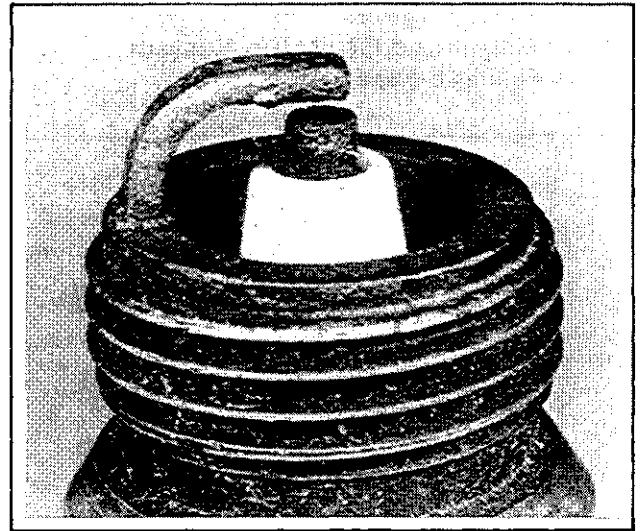

**Chalky White Deposits:** Chalky white colored deposits indicate overheating. This condition is usually accompanied by excessive gap erosion. A clogged grass screen, clogged cooling fins, and lean carburetion are some causes of over-heating.

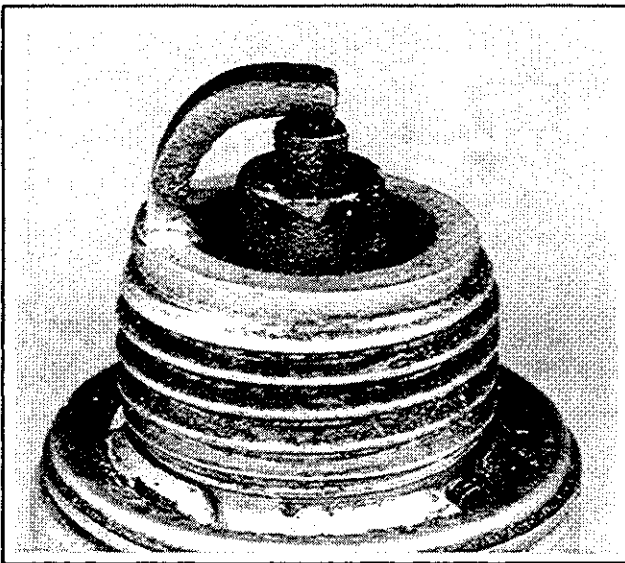

**Wet Fouled:** A wet plug is caused by excess fuel, or oil in the combustion chamber. Excess fuel could be caused by operating the engine with too much choke. Oil in the combustion chamber is usually caused by worn piston rings or valve guides.

## ELECTRICAL SYSTEMS WIRING DIAGRAMS AND BATTERY CHARGING SYSTEMS

The following battery charging systems are available on Magnum twin cylinder engines.

- 15 Amp Regulated Battery Charging System
- 25 Amp Regulated Battery Charging System

Refer to the following wiring diagrams and troubleshooting guides to test and service these battery charging systems.

**CAUTION:** To prevent damage to the electrical system and components:

1. Make sure battery polarity is correct. A negative (-) ground system is used.
2. Disconnect the rectifier-regulator leads and/or wiring harness plug before electric welding is done on the equipment powered by the engine. Also disconnect other electrical accessories in common ground with the engine.
3. Prevent the stator (AC) leads from touching or shorting. This could permanently damage the stator.

**Electric Start Engines**  
**15 Amp Regulated Charging System**  
 (Refer to Figures 8-8 and 8-9.)

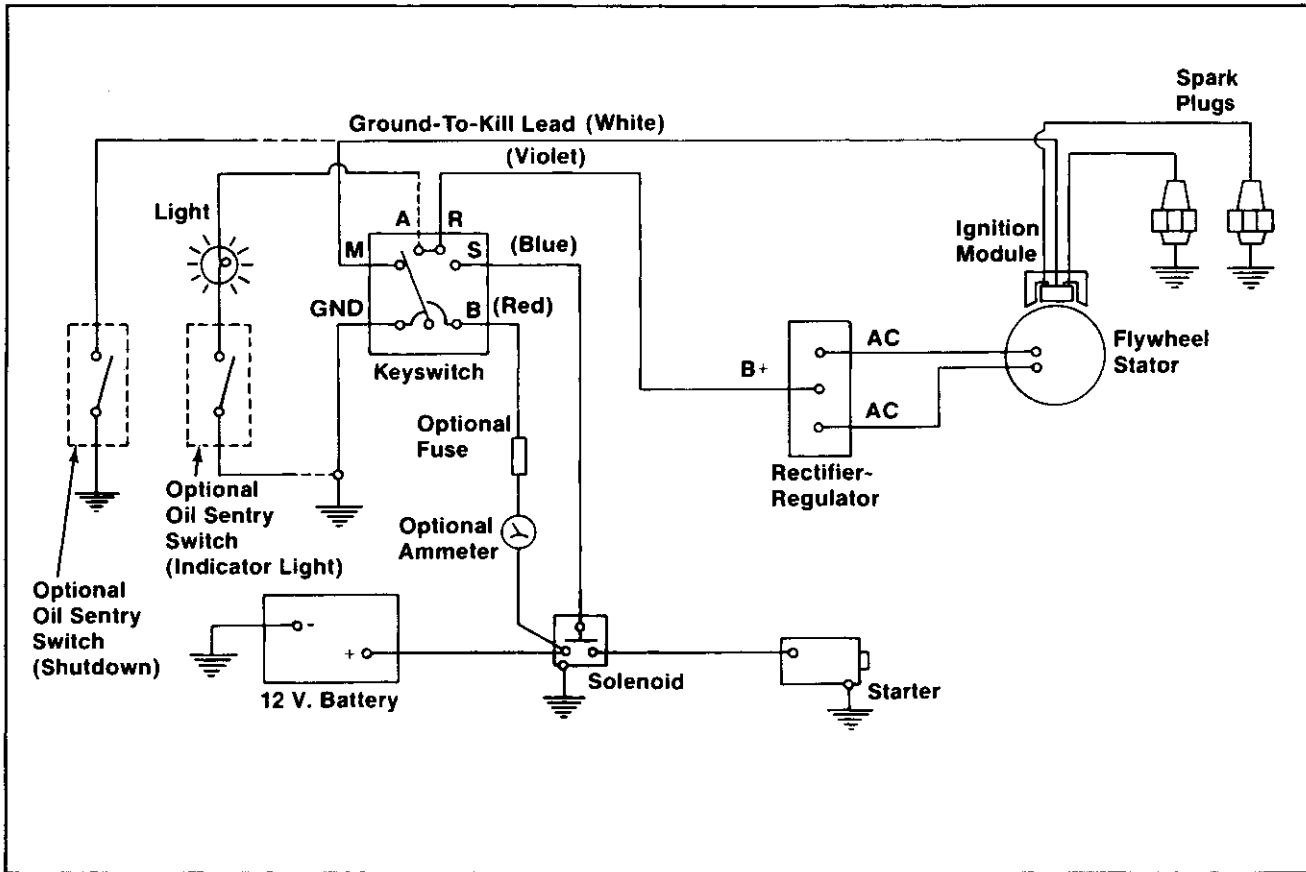

**Figure 8-8. Wiring Diagram - Electric Start Engines/15 Amp Regulated Battery Charging System.**

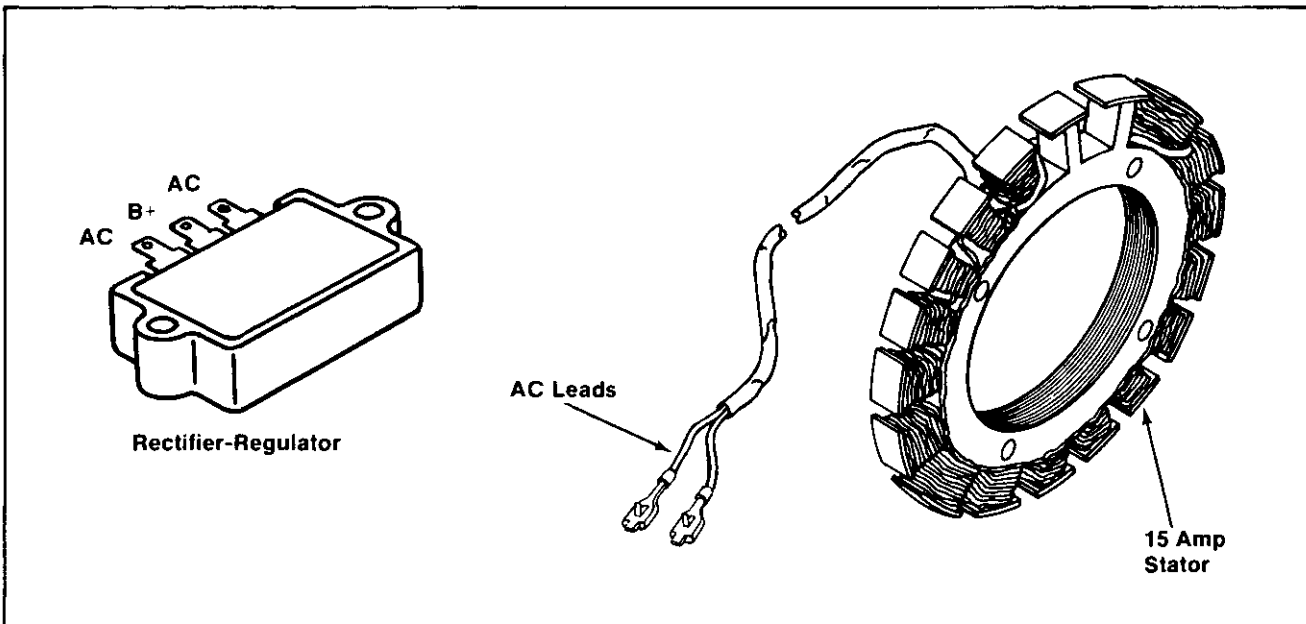

**Figure 8-9. 15 Amp Stator And Rectifier-Regulator.**

## Troubleshooting Guide

### 15 Amp Battery Charging System

NOTE: Zero ohmmeters and voltmeters on each scale to ensure accurate readings. Voltage tests should be made with engine running at 3600 RPM - no load. Battery must be fully charged.

Problem	Test	Conclusion
<b>NO CHARGE TO BATTERY</b>	<p>1. Insert an ammeter in B+ lead from rectifier-regulator. With engine running at 3600 RPM and B+ lead connected, measure the voltage from B+ (at terminal on rectifier-regulator) to ground using a DC voltmeter.</p> <p>If voltage is 13.8 volts or more, place a minimum load of 5 Amps* on battery to reduce voltage. Observe ammeter.</p> <p>*NOTE: Turn on lights, if 60 watts or more. Or place a 2.5 ohm, 100 watt resistor across battery terminals.</p>	<p>1. If charge rate <b>increases</b> when load is applied, the charging system is OK and battery was fully charged.</p> <p>If charge rate does not increase when load is applied, test stator and rectifier-regulator (tests 2 and 3).</p>
	<p>2. Remove connector from rectifier-regulator. With engine running at 3600 RPM, measure AC voltage across stator leads using an AC voltmeter.</p>	<p>2. If voltage is <b>28 volts or more</b>, stator is OK. Rectifier-regulator is faulty. Replace the rectifier-regulator.</p> <p>If voltage is less than 28 volts, stator is probably faulty and should be replaced. Test stator further using an ohmmeter (test 3).</p>
	<p>3a. With engine stopped, measure the resistance across stator leads using an ohmmeter.</p>	<p>3a. If resistance is <b>0.1/0.2 ohms</b>, the stator is OK.</p> <p>If resistance is 0 ohms, the stator is shorted. Replace stator.</p> <p>If resistance is infinity ohms, stator is open. Replace stator.</p>
	<p>3b. With engine stopped, measure the resistance from each stator lead to ground using an ohmmeter.</p>	<p>3b. If resistance is <b>infinity ohms</b> (no continuity), the stator is OK (not shorted to ground).</p> <p>If resistance (or continuity) is measured, the stator leads are shorted to ground. Replace stator.</p>
<b>BATTERY CONTINUOUSLY CHARGES AT HIGH RATE</b>	<p>1. With engine running at 3600 RPM, measure voltage from B+ lead to ground using a DC voltmeter.</p>	<p>1. If voltage is <b>14.7 volts or less</b> the charging system is OK. The battery is unable to hold charge. Service battery or replace as necessary.</p> <p>If voltage is more than 14.7 volts, the rectifier-regulator is faulty. Replace rectifier-regulator.</p>

**Electric Start Engines**  
**25 Amp Regulated Charging System**  
 (Refer to Figures 8-10 and 8-11.)

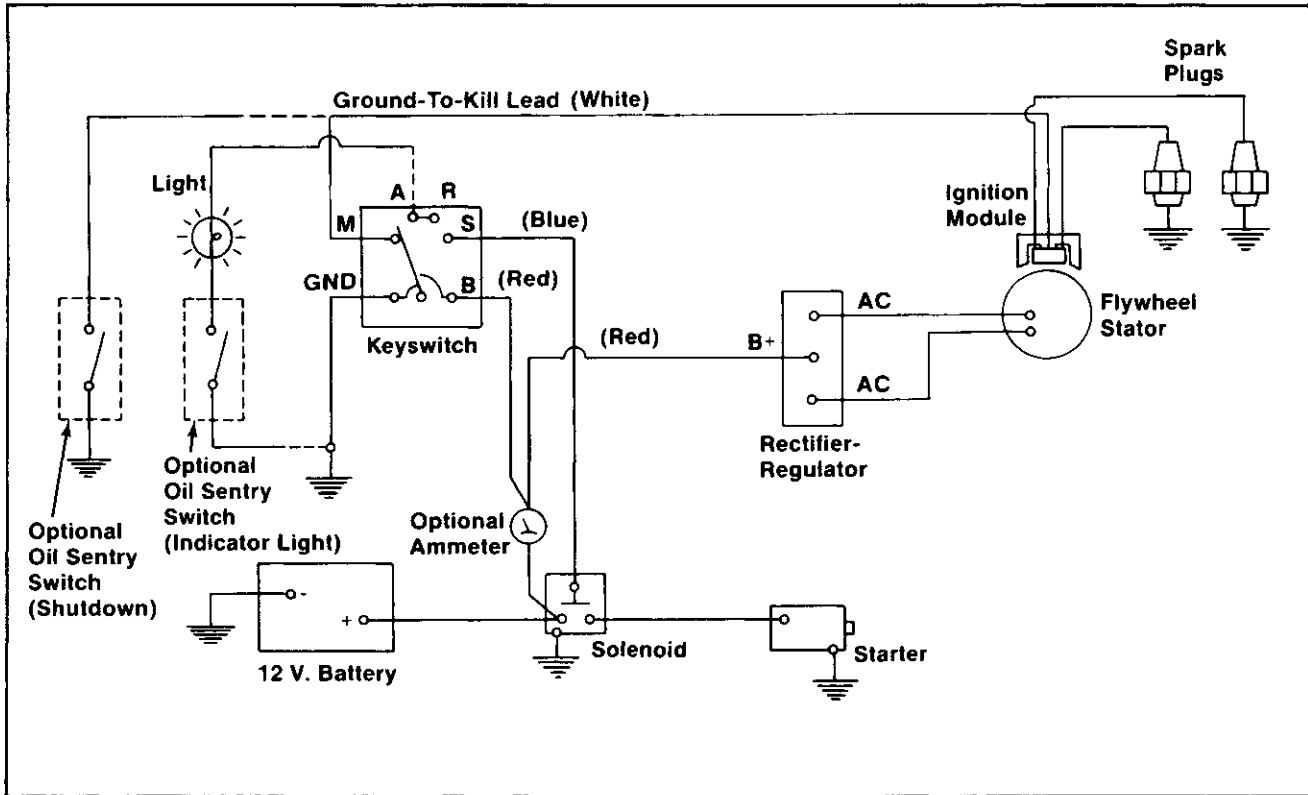

**Figure 8-10. Wiring Diagram - Electric Start Engines/25 Amp Regulated Battery Charging System.**

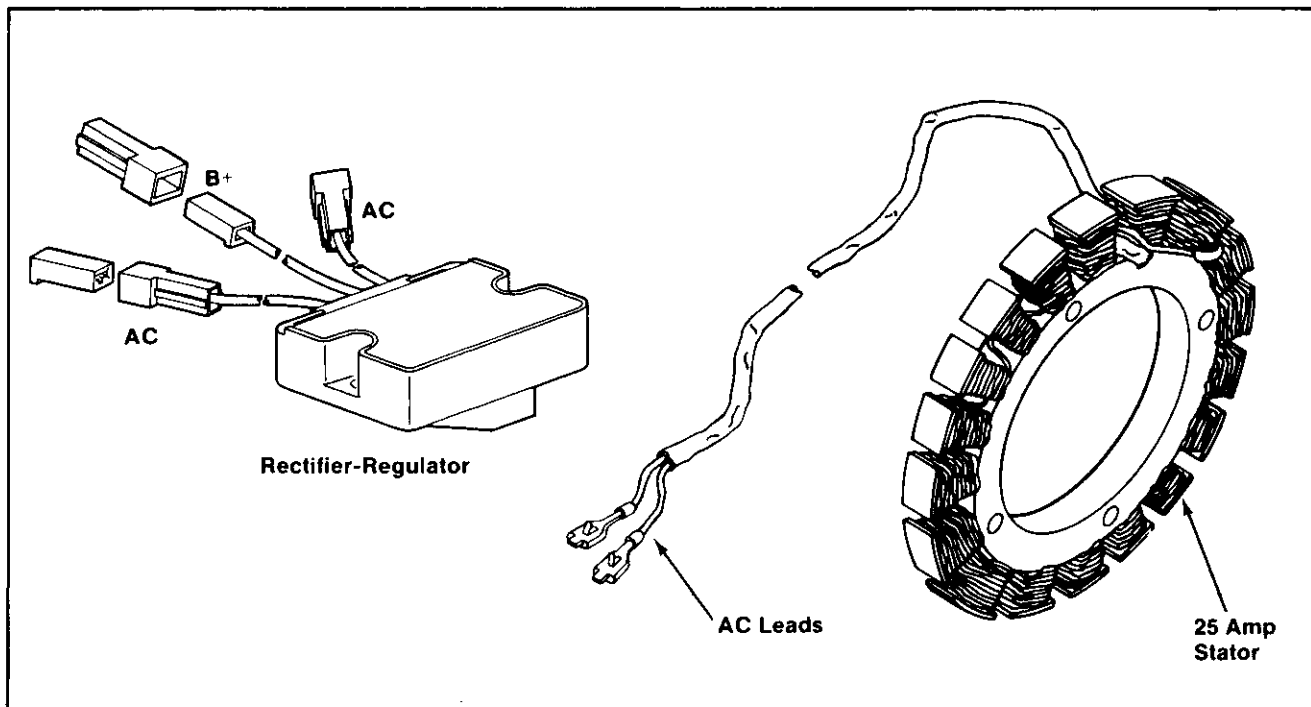

**Figure 8-11. 25 Amp Stator And Rectifier-Regulator.**



## Troubleshooting Guide

### 25 Amp Battery Charging System

NOTE: Zero ohmmeters and voltmeters on each scale to ensure accurate readings. Voltage tests should be made with engine running at 3600 RPM - no load. Battery must be fully charged.

Problem	Test	Conclusion
<b>NO CHARGE TO BATTERY</b>	<p>1. Insert an ammeter in B+ lead from rectifier-regulator. With engine running at 3600 RPM and B+ lead connected, measure the voltage from B+ (at terminal on rectifier-regulator) to ground using a DC voltmeter.</p> <p>If voltage is 13.8 volts or more, place a minimum load of 5 Amps* on battery to reduce voltage. Observe ammeter.</p> <p>*NOTE: Turn on lights, if 60 watts or more. Or place a 2.5 ohm, 100 watt resistor across battery terminals.</p>	<p>1. If charge rate <b>increases</b> when load is applied, the charging system is OK and battery was fully charged.</p> <p>If charge rate does not increase when load is applied, test stator and rectifier-regulator (tests 2 and 3).</p>
	<p>2. Remove connector from rectifier-regulator. With engine running at 3600 RPM, measure AC voltage across stator leads using an AC voltmeter.</p>	<p>2. If voltage is <b>28 volts or more</b>, stator is OK. Rectifier-regulator is faulty. Replace the rectifier-regulator.</p> <p>If voltage is less than 28 volts, stator is probably faulty and should be replaced. Test stator further using an ohmmeter (test 3).</p>
	<p>3a. With engine stopped, measure the resistance across stator leads using an ohmmeter.</p>	<p>3a. If resistance is <b>0.064/0.096 ohms</b> the stator is OK.</p> <p>If resistance is 0 ohms, the stator is shorted. Replace stator.</p> <p>If resistance is infinity ohms, stator is open. Replace stator.</p>
	<p>3b. With engine stopped, measure the resistance from each stator lead to ground using an ohmmeter.</p>	<p>3b. If resistance is <b>infinity ohms</b> (no continuity), the stator is OK (not shorted to ground).</p> <p>If resistance (or continuity) is measured, the stator leads are shorted to ground. Replace stator.</p>
<b>BATTERY CONTINUOUSLY CHARGES AT HIGH RATE</b>	<p>1. With engine running at 3600 RPM, measure voltage from B+ lead to ground using a DC voltmeter.</p>	<p>1. If voltage is <b>14.7 volts or less</b> the charging system is OK. The battery is unable to hold charge. Service battery or replace as necessary.</p> <p>If voltage is more than 14.7 volts, the rectifier-regulator is faulty. Replace rectifier-regulator.</p>

## BATTERY

Batteries are supplied by the equipment manufacturer. A 12-volt battery with a rating of 32 amp. hr./250 cold cranking amps is normally used. Refer to the equipment manufacturer's instructions for specific information.

### Battery Test

If the battery charge is not sufficient to crank the engine, recharge the battery.

**CAUTION:** Do not attempt to "jump start" the engine with another battery. Starting the engine with batteries larger than those recommended can burn out the starter motor.

Test the battery voltage by connecting D.C. voltmeter across the battery terminals—crank the engine. If the battery drops below 9 volts while cranking, the battery is discharged or faulty. Refer to Figure 8-12.

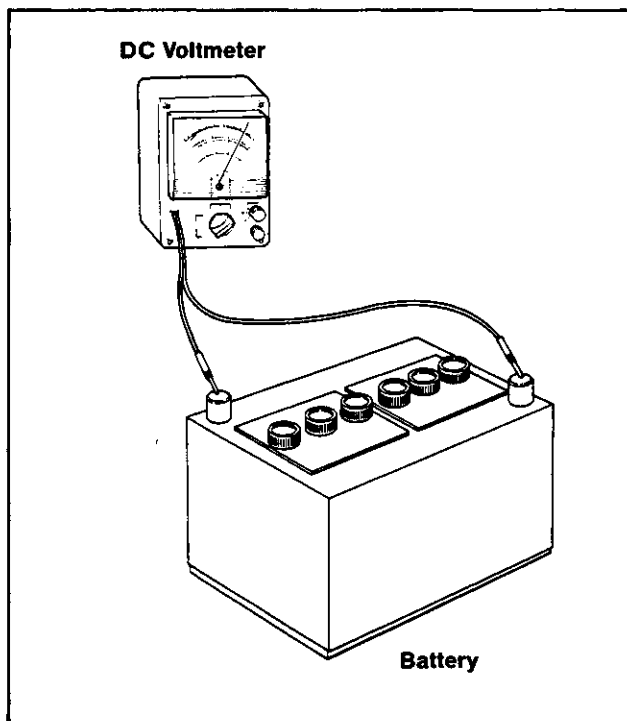

Figure 8-12. Checking Battery Voltage.

### Battery Charging

**WARNING: Dangerous Acid, Explosive Gases!**  
Batteries contain sulphuric acid. To prevent acid burns, avoid contact with skin, eyes, and clothing.



*Batteries produce explosive hydrogen gas while being charged. Charge the battery in well ventilated areas. Keep cigarettes, sparks, open flame, and other sources of ignition away from battery at all times.*

*To prevent accidental shorting and the resulting sparks, remove all jewelry when servicing the battery.*

*When disconnecting battery cables, always disconnect the negative (-) (ground) cable first. When connecting battery cables, always connect the negative cable last.*

*Before disconnecting the negative (-) ground cable, make sure all switches are OFF. If ON, a spark will occur at the ground cable terminal which could cause an explosion if hydrogen gas or gasoline vapors are present.*

*Keep batteries and acid out of the reach of children.*

### Battery Maintenance

Regular maintenance will ensure the battery will accept and hold a charge.

1. Regularly check the level of electrolyte. Add **distilled** water as necessary to maintain the recommended level.

**CAUTION:** Do not overfill the battery. Poor performance or early failure due to loss of electrolyte will result.

2. Keep the cables, terminals, and external surfaces of battery clean. A build-up of corrosive acid or grime on the external surfaces can self-discharge the battery. Self-discharging happens rapidly when moisture is present.

Wash the cables, terminals, and external surfaces with a baking soda and water solution. Rinse thoroughly with clear water.

**CAUTION:** Do not allow the baking soda solution to enter the cells as this will destroy the electrolyte.

### KEYSWITCH

The Kohler-supplied keyswitch typically used with MV16 and MV18 engines is shown in Figure 8-13. It is a three position (OFF, RUN, START), break-before-make type switch.

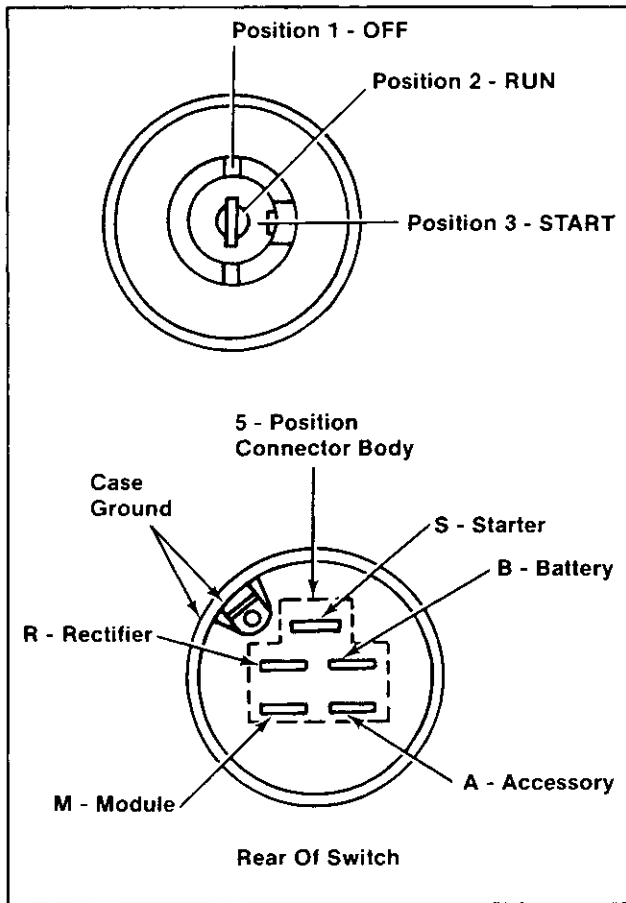

Figure 8-13. Keyswitch.

### Testing

Test the switch for continuity using an ohmmeter or continuity test light. For each switch position, continuity should be present across the terminals listed in the table below.

Switch Position	Continuity Across Terminals
1 - OFF	G + M + A
2 - RUN	B + A + R
3 - START	B + S

### SOLENOID

The Kohler-supplied solenoid typically used on engines equipped with a keyswitch is shown in Figure 8-14. The solenoid is an electrically-actuated normally open switch designed for heavy current loads.

The solenoid is used to switch the heavy current required by the starter using the keyswitch (designed for low current loads).

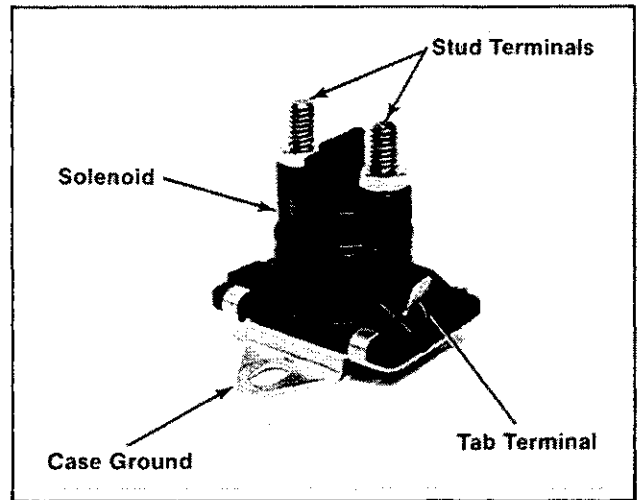

Figure 8-14. Starter Solenoid.

### Testing

1. Connect an ohmmeter or continuity tester across the stud terminals of solenoid.
2. Apply 12 volts DC across the tab terminal and case ground of solenoid and observe ohmmeter or tester.

NOTE: Apply positive (+) of voltage supply to tab terminal; negative (-) to case ground.

3. **The ohmmeter or tester should indicate continuity as long as voltage is applied.** If there is no continuity, the solenoid is probably faulty and should be replaced.

Check the solenoid further using an ohmmeter (step 4).

4. Measure the resistance of the coil in the solenoid using an ohmmeter. Connect one meter lead to the case ground and one lead to the tab terminal.

If the resistance is **5.2/6.3 ohms**, the coil is OK.

If the resistance is low or 0 ohms, the coil is shorted. Replace solenoid.

If the resistance is infinity ohms, the coil is open. Replace solenoid.

### ELECTRIC STARTER

These engines use a permanent magnet, bendix-drive electric starter. Refer to Figure 8-15.

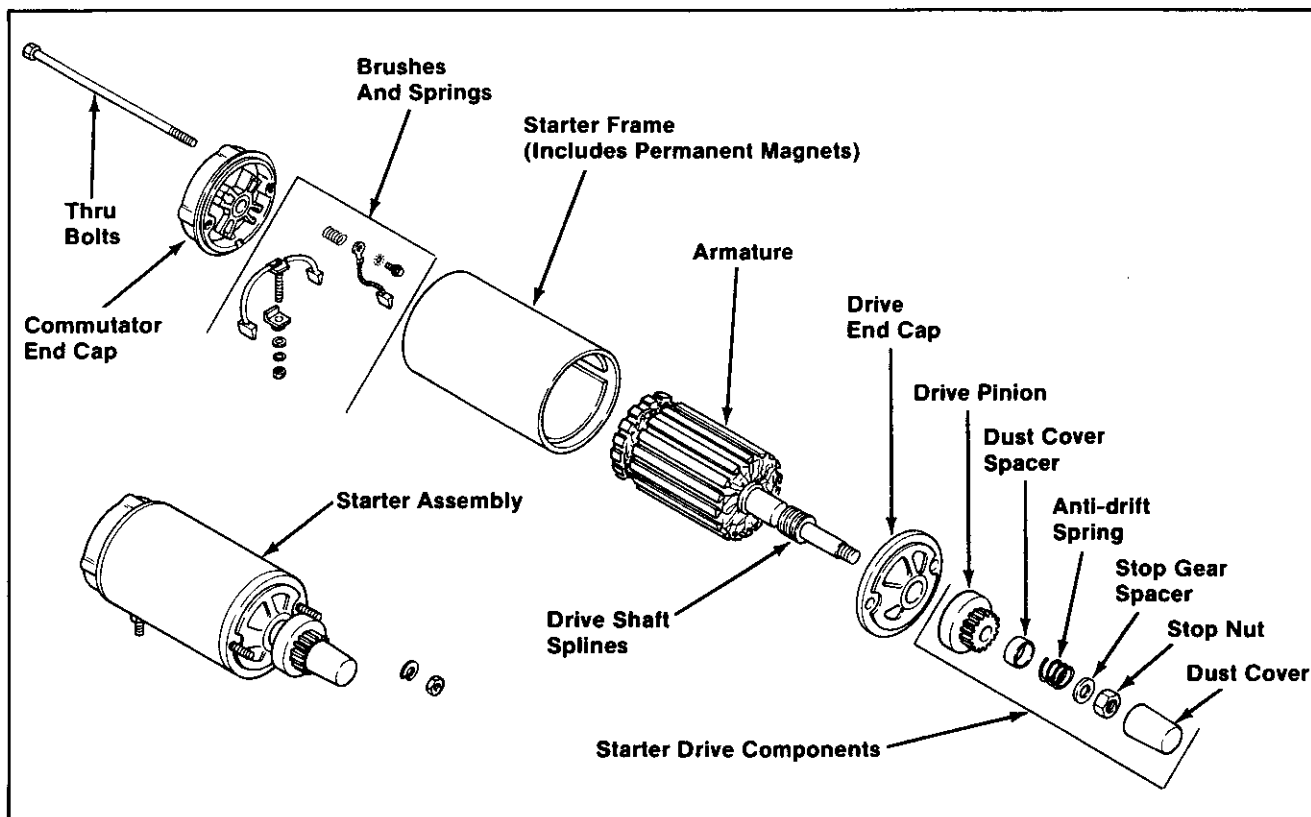

Figure 8-15. Bendix Drive Electric Starter.

## Operation

When power is applied to the starter, the armature rotates. As the armature rotates, the drive pinion moves out on the splined drive shaft into mesh with the flywheel ring gear. When the pinion reaches the end of the drive shaft, it rotates the flywheel cranking the engine.

When the engine starts, the flywheel rotates faster than the armature and drive pinion. This moves the drive pinion out of mesh with the ring gear and into the retracted position. When power is removed from the starter, the armature stops rotating and the pinion is held in the retracted position by the anti-drift spring.

**CAUTION:** Do not crank the engine continuously for more than 10 seconds at a time. If the engine does not start, allow a 60 second cool-down period between starting attempts. Failure to follow these guidelines can burn out the starter motor.

**CAUTION:** If the engine develops sufficient speed to disengage the starter but does not keep running (a "false start"), the engine rotation must be allowed to come to a complete stop before attempting to restart the engine. If the starter is engaged while the flywheel is rotating, the starter pinion and flywheel ring gear may clash. This can damage the starter.

**CAUTION:** If the starter does not crank the engine, shut off the starter immediately. Do not make further attempts to start the engine until the condition is corrected. Do not jump start using another battery. Using batteries larger than those recommended can burn out the starter motor.

**CAUTION:** Do not drop the starter or strike the starter frame. Doing so can damage the ceramic permanent magnets.

## Troubleshooting Guide

Problem	Possible Fault	Correction
<b>STARTER FAILS TO ENERGIZE</b>	<b>Wiring</b>	1. Clean corroded connections and tighten loose connections. 2. Replace wires in poor condition and with frayed or broken insulation.
	<b>Starter Switch or Solenoid</b>	Bypass the switch or solenoid with a jumper wire—if starter cranks normally, replace the faulty parts.
	<b>Battery</b>	Check specific gravity of battery. If low, recharge or replace battery as necessary.
<b>STARTER ENERGIZES BUT TURNS SLOWLY</b>	<b>Battery</b>	Check specific gravity of battery. If low, recharge or replace battery as necessary.
	<b>Brushes</b>	Check for excessively dirty or worn brushes and commutator. Clean using a coarse cloth (not emery paper). Replace brushes if excessively or unevenly worn.
	<b>Transmission Or Engine</b>	Make sure the clutch or transmission is disengaged or placed in neutral. This is especially important on equipment with hydrostatic drive. The transmission must be exactly in neutral to prevent resistance which could keep the engine from starting.  Check for seized engine components such as the bearings, connecting rod, and piston.

### Starter Drive Service

Every 500 operating hours or annually (whichever comes first), clean and lubricate the drive splines of the starter. If the drive pinion is badly worn, or has chipped or broken teeth, it must be replaced.

It is not necessary to disassemble the starter to service the drive components. Refer to Figure 8-15 and service drive as follows:

1. Hold the drive pinion in a vise with soft jaws when removing and installing the stop nut. The armature will rotate with the nut only until the drive pinion stops against internal spacers.  
  
**CAUTION:** Do not overtighten the vise as this can distort the drive pinion.
2. Remove the dust cover, stop nut, stop gear spacer, anti-drift spring, dust cover spacer, and drive pinion.
3. Clean the drive shaft splines with solvent. Dry the splines thoroughly.
4. Apply a small amount of Kohler electric starter drive lubricant (Part No. 52 357 01) to splines.

**CAUTION:** Kohler starter drive lubricant (Part No. 52 357 01) must be used on all Kohler electric starter drives. The use of other lubricants can cause the drive to stick or bind.

5. Apply a small amount of Loctite® No. 271 to stop nut threads.
6. Reinstall the drive pinion, dust cover spacer, anti-drift spring, stop gear spacer, and stop nut. Torque stop nut to **160 in. lb.** Install the dust cover.

### Disassembly

1. Remove the dust cover, stop nut, stop gear spacer, anti-drift spring, dust cover spacer, and drive pinion. Refer to "Starter Drive Service."
2. Remove the thru bolts.
3. Remove the drive end cap and thrust washer.
4. Remove the commutator end cap with brushes and springs.
5. Remove the armature from inside the starter frame.

### Brush Replacement (Refer to Figure 8-16.)

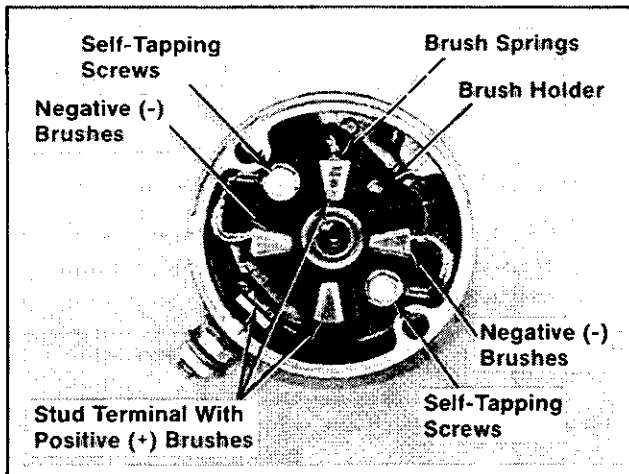

Figure 8-16. Commutator End Cap With Brushes.

1. Remove the brush springs from the pockets in brush holder.
2. Remove the self-tapping screws, negative (-) brushes, and plastic brush holder.
3. Remove the hex nut, split lock washer, plain washer, and fiber washer from the stud terminal. Remove the stud terminal with positive (+) brushes and plastic insulating bushing from end cap.
4. Reinstall the insulating bushing to new stud terminal with positive (+) brushes. Install the bushing and stud terminal into end cap. Secure with the fiber washer, plain washer, split lock washer, and hex nut.
5. Install the brush holder and new negative (-) brushes. Secure with the self-tapping screws.
6. Install the brush springs and brushes into the pockets in brush holder. Make sure the chamfered sides of brushes are away from the springs.

NOTE: Use a brush holder tool to keep the brushes in the pockets. A brush holder tool can easily be made from thin sheet metal. Refer to Figure 8-17.

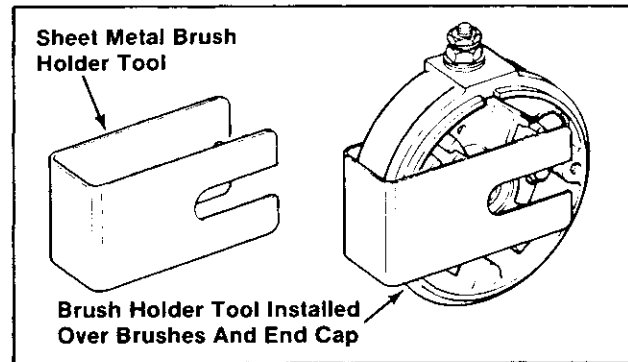

Figure 8-17. Brush Holder Tool.

### Commutator Service

Clean the commutator with a coarse, lint free cloth. Do not use emery cloth. If the commutator is badly worn or grooved, turn down on a lathe, or replace the armature.

### Reassembly

1. Insert the armature into the starter frame. Make sure the magnets are closer to the drive shaft end of armature. The magnets will hold the armature inside the frame.
2. Install the thrust washer and drive end cap. Make sure the match marks on end cap and frame are aligned. Refer to Figure 8-18.

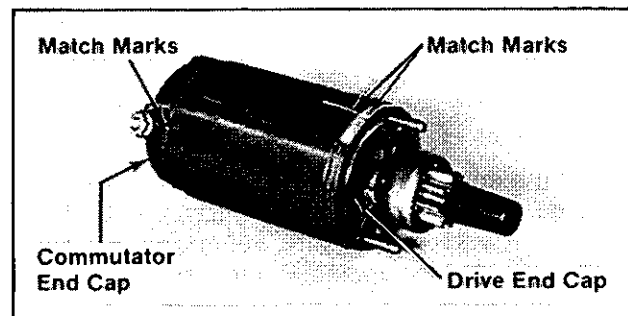

Figure 8-18. Starter Assembly Match Marks.

3. Install the brush holder tool to keep the brushes in the pockets of commutator end cap. Refer to Figure 8-17.
4. Install the commutator end cap to armature and starter frame. Firmly hold the drive end cap and commutator end cap to the starter frame. Remove the brush holder tool.
5. Make sure the match marks on end cap and frame are aligned. Refer to Figure 8-18. Install the thru bolts and tighten securely.
6. Install the drive pinion, dust cover spacer, anti-drift spring, stop gear spacer, stop nut, and dust cover. Refer to "Starter Drive Service."

# SECTION 9 DISASSEMBLY

**WARNING: Accidental Starts!**



*Before servicing the engine or equipment, always remove the spark plug leads to prevent the engine from starting accidentally. Ground the leads to prevent sparks that could cause fires.*

The following sequence is suggested for complete engine disassembly. This procedure may have to be varied slightly to accommodate options or special equipment.

Clean all parts thoroughly as the engine is disassembled. Only clean parts can be accurately inspected and gauged for wear and damage. There are many commercially available cleaners that quickly remove grease, oil, and grime from engine parts. When such a cleaner is used, follow the manufacturer's instructions carefully. Make sure all traces of the cleaner are removed before the engine is reassembled and placed in operation—even small amounts of these cleaners quickly break down the lubricating properties of engine oil.

1. Disconnect spark plug leads.
2. Drain oil and remove oil filter.
3. Remove mufflers.
4. Remove air cleaner.
5. Remove external governor components, intake manifold, and carburetor.
6. Disconnect wiring and remove rectifier-regulator.
7. Remove breather and valve cover.
8. Remove top baffle, support baffle, cylinder head baffles, and blower housing.
9. Remove fuel pump.
10. Remove ignition module and bracket.
11. Remove electric starter.
12. Remove grass screen, flywheel, and fan.
13. Remove stator.

14. Identify engine sides.
15. Remove spark plugs and cylinder heads.
16. Remove cylinder barrels.
17. Remove valves.
18. Remove pistons from connecting rods.
19. Remove piston rings.
20. Remove oil filter adapter.
21. Remove oil pan, oil pressure relief valve, oil pickup screen, and oil seal.
22. Split the crankcase.
23. Remove camshaft and tappets.
24. Remove crankshaft, oil seal, and bearings.
25. Remove connecting rods.
26. Remove governor gear and cross shaft.
27. Remove oil pump.

## DISCONNECT SPARK PLUG LEADS

## DRAIN OIL AND REMOVE OIL FILTER

1. Remove the oil fill cap/dipstick, and oil drain plug. Drain the oil from crankcase. Refer to Figure 9-1.

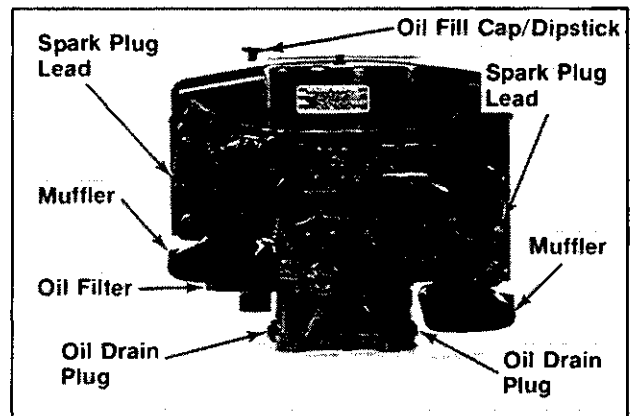

Figure 9-1. Removing Spark Plug Leads, Oil Drain Plug, Oil Filter, And Mufflers.

2. Remove and discard the oil filter.

## REMOVE MUFFLERS

1. Remove the hex socket head screws, split lock washers, mufflers, and gaskets. Refer to Figure 9-2.

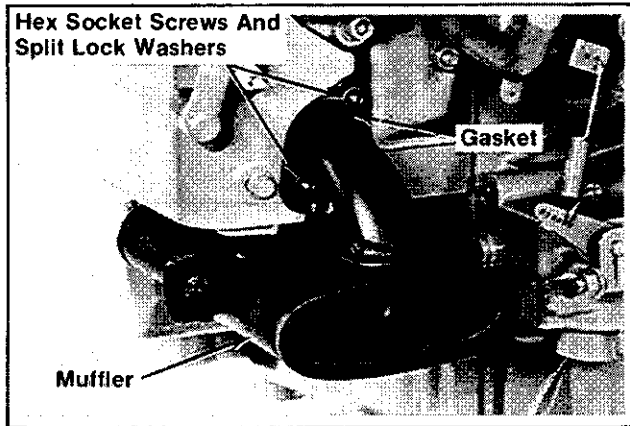

Figure 9-2. Removing Mufflers.

## REMOVE AIR CLEANER

1. Remove the wing nut and air cleaner cover. Refer to Figure 9-3.

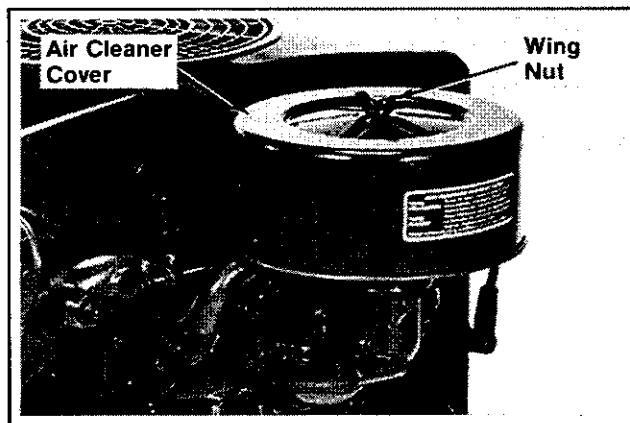

Figure 9-3. Removing Air Cleaner Cover.

2. Remove the seal, element cover, paper element, and optional precleaner. Refer to Figure 9-4.

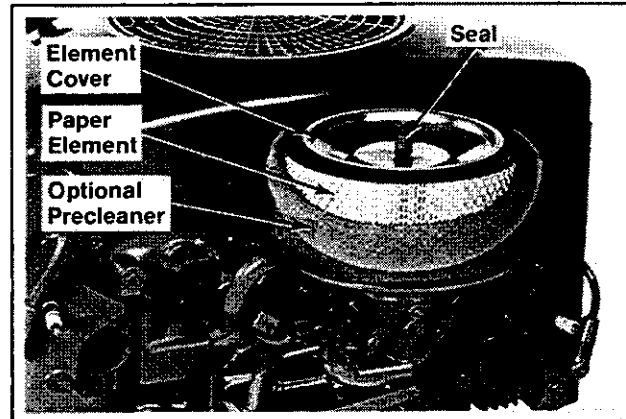

Figure 9-4. Removing Air Cleaner Element.

3. Remove the four screws securing air cleaner base to intake elbow. Remove the base, breather hose, and gasket. Refer to Figure 9-5.

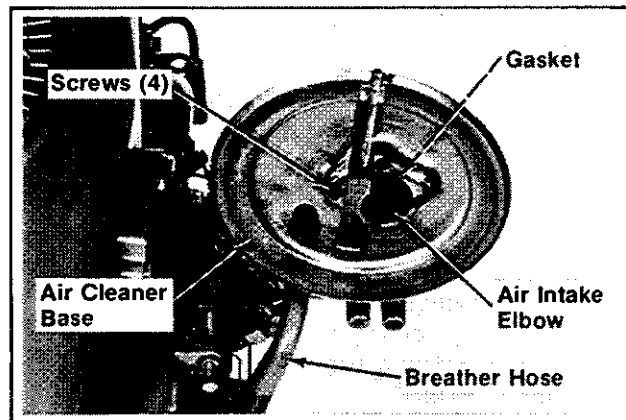

Figure 9-5. Removing Air Cleaner Base.

## REMOVE EXTERNAL GOVERNOR COMPONENTS, INTAKE MANIFOLD, AND CARBURETOR

### WARNING: Explosive Fuel!



Gasoline may be present in the intake manifold, carburetor, and fuel system. Gasoline is extremely flammable, and its vapors can explode if ignited. Keep cigarettes, sparks, open flames, and other sources of ignition away from the engine. Wipe up spilled fuel immediately.

1. Refer to Figures 9-6 and 9-7. Mark or note the position of governor spring in governor arm and speed control lever. Remove the governor spring.



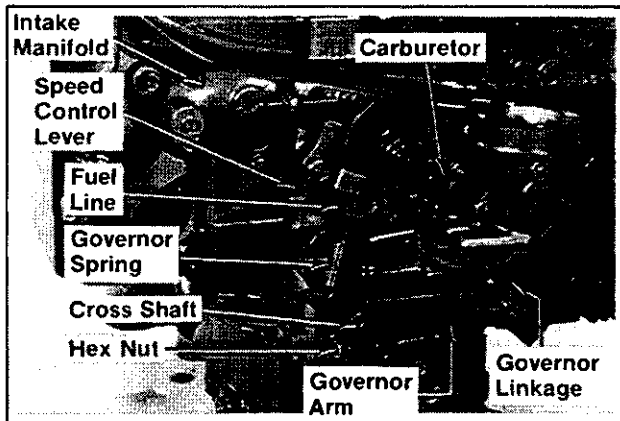

Figure 9-6. Removing External Governor Components.

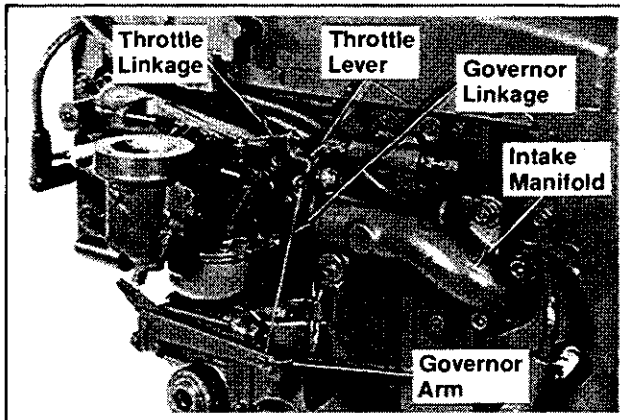

Figure 9-7. Removing External Governor Components.

2. Remove the governor linkage from the governor arm and the throttle lever on intake manifold.

NOTE: The linkages on some engines are secured with small retaining clips. Remove these clips then remove linkages.

3. Loosen the hex nut and remove governor arm and plain washer from cross shaft.

NOTE: Loosening the hex nut or removing governor arm will disrupt governor arm-to-cross shaft adjustment. Readjustment will be required upon reassembly.

4. Loosen the hose clamp and remove fuel line from the carburetor inlet fitting. Refer to Figure 9-8.

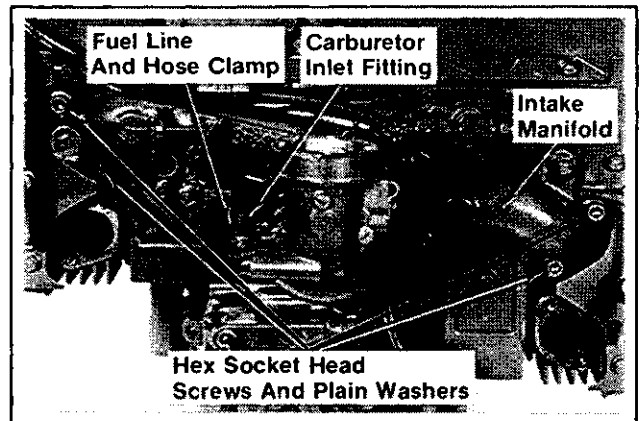

Figure 9-8. Removing Intake Manifold With Carburetor.

5. Remove the hex socket head screws, plain washers, intake manifold with carburetor, and intake manifold gaskets.
6. Remove the throttle linkage from throttle lever on carburetor and throttle lever on intake manifold. Refer to Figure 9-7.
7. Remove the hex nuts, carburetor with intake elbow, and gasket from intake manifold. Refer to Figure 9-9.

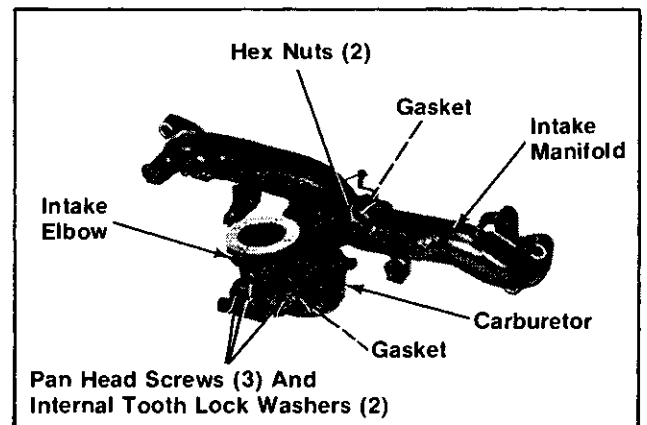

Figure 9-9. Removing Carburetor And Intake Elbow.

8. Remove the pan head screws, internal tooth lock washers, intake elbow, and gasket from carburetor.

## DISCONNECT WIRING AND REMOVE RECTIFIER-REGULATOR.

1. Remove the connector from rectifier-regulator.
2. Remove the hex cap screws and rectifier-regulator from blower housing. Refer to Figure 9-10.

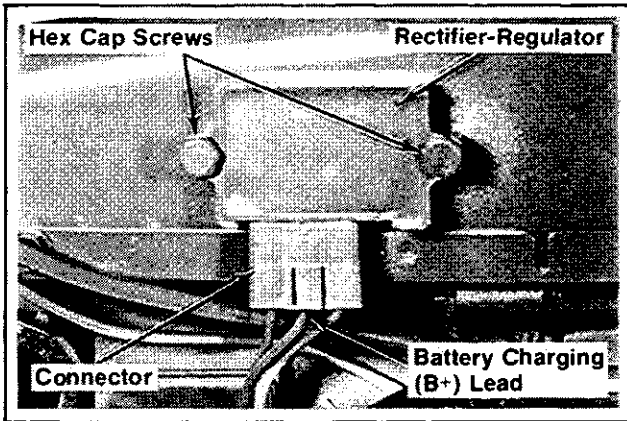

Figure 9-10. Removing Rectifier-Regulator.

3. Remove the battery charging (B+) lead from center position of connector body.

## REMOVE BREATHER AND VALVE COVER

### On #1 Side

1. Remove the hex nut, copper washer, breather cover, and gasket. Refer to Figure 9-11.

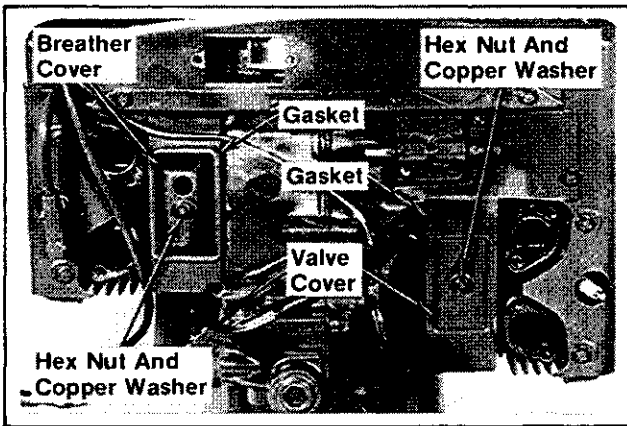

Figure 9-11. Removing Breather And Valve Cover.

2. Remove the seal, breather plate, and gasket. Refer to Figure 9-12.

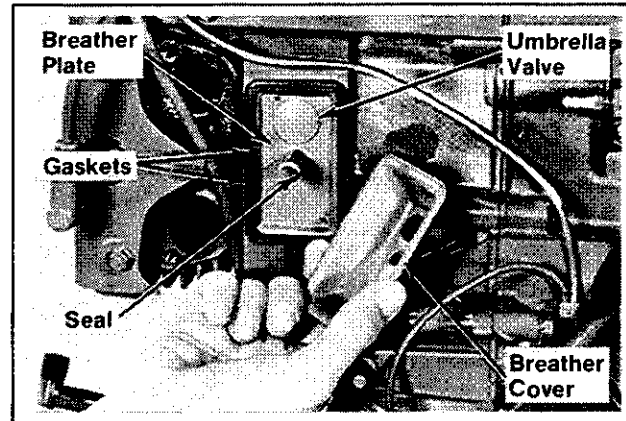

Figure 9-12. Removing Breather Components.

3. Remove the umbrella valve from breather plate for inspection, if necessary.

### On #2 Side

1. Remove the hex nut, copper washer, valve cover, and gasket. Refer to Figure 9-11.

## REMOVE TOP BAFFLE, SUPPORT BAFFLE, CYLINDER HEAD Baffles, AND BLOWER HOUSING

1. Remove the self-tapping screws, top baffle, and support baffle. Refer to Figure 9-13.

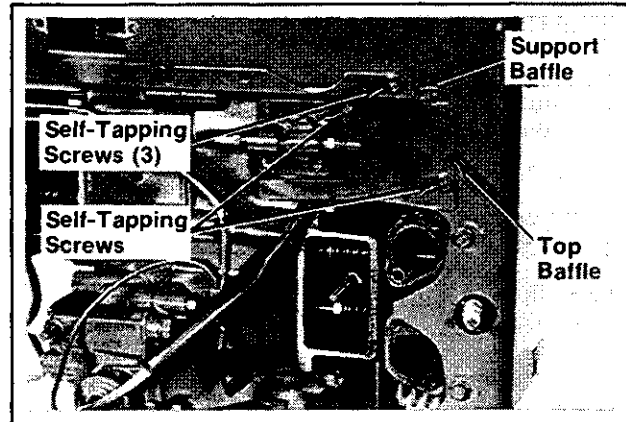

Figure 9-13. Removing Top Baffle And Support Baffle.

2. Remove the self-tapping screws and #2 side cylinder head baffle. Refer to Figure 9-14.

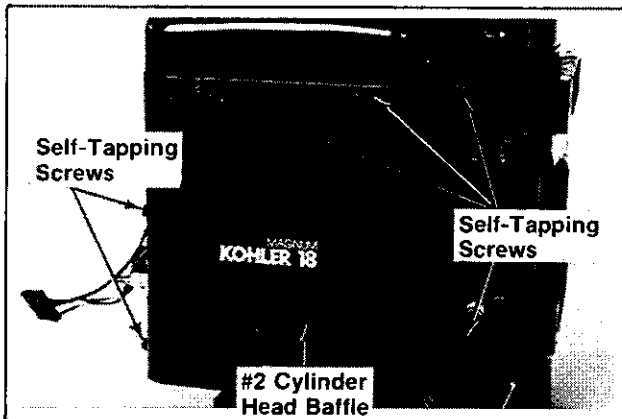

Figure 9-14. Removing #2 Side Cylinder Head Baffle.

3. Remove self-tapping screws securing the oil fill tube bracket to #1 side cylinder head baffle and blower housing. Remove o-ring from oil fill tube and slide bracket off of tube. Remove remaining self-tapping screws and #1 side cylinder head baffle. Refer to Figure 9-15.

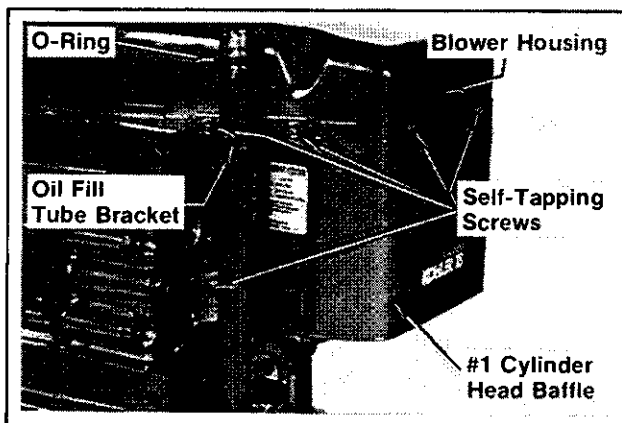

Figure 9-15. Removing #1 Side Cylinder Head Baffle.

4. Remove the self-tapping screws and blower housing from crankcase. Refer to Figure 9-16.

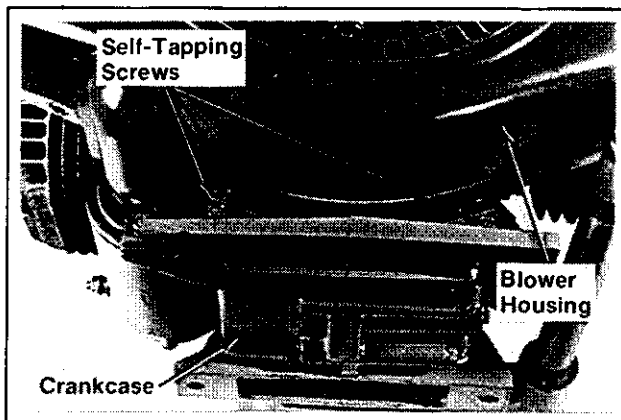

Figure 9-16. Removing Blower Housing.

## REMOVE FUEL PUMP

### WARNING: Explosive Fuel!



Gasoline may be present in the fuel pump. Gasoline is extremely flammable, and its vapors can explode if ignited. Keep cigarettes, sparks, open flames, and other sources of ignition away from engine. Wipe up spilled fuel immediately.

1. Remove the truss head screws, fuel pump, and gasket. Refer to Figure 9-17.

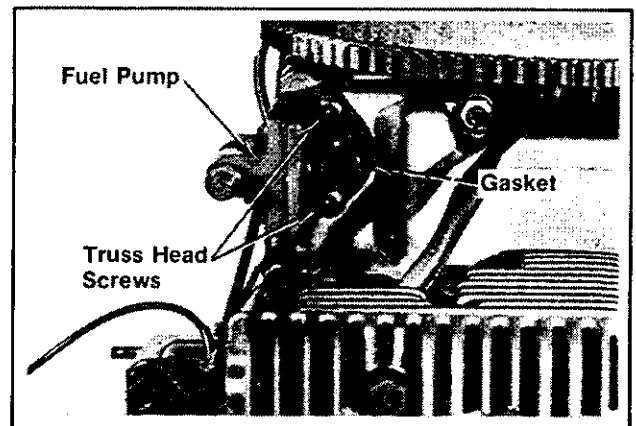

Figure 9-17. Removing Fuel Pump.

## REMOVE IGNITION MODULE AND BRACKET

1. Remove the hex flange screws and ignition module from bracket on #1 side cylinder barrel. Refer to Figure 9-18.

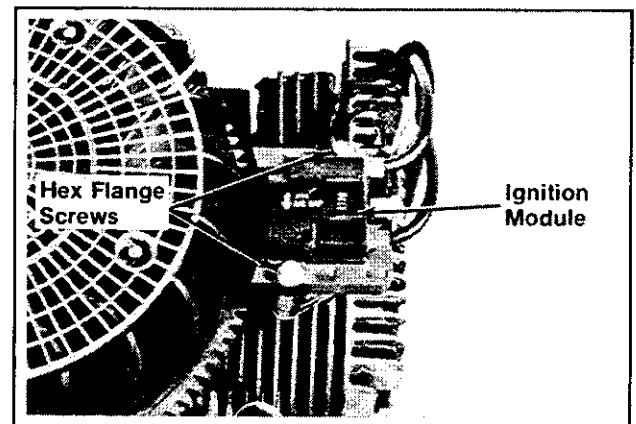

Figure 9-18. Removing Ignition Module.

2. Remove the hex flange screws and bracket from #1 side cylinder barrel. Refer to Figure 9-19.

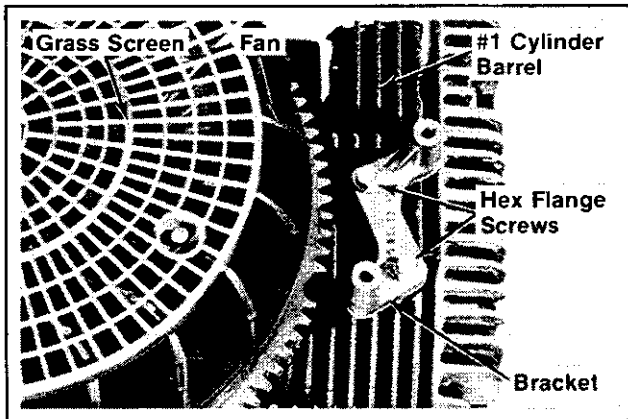

Figure 9-19. Removing Ignition Module Bracket.

## REMOVE ELECTRIC STARTER

1. Remove the hex nuts, split lock washers, and starter motor from crankcase. Refer to Figure 9-20.

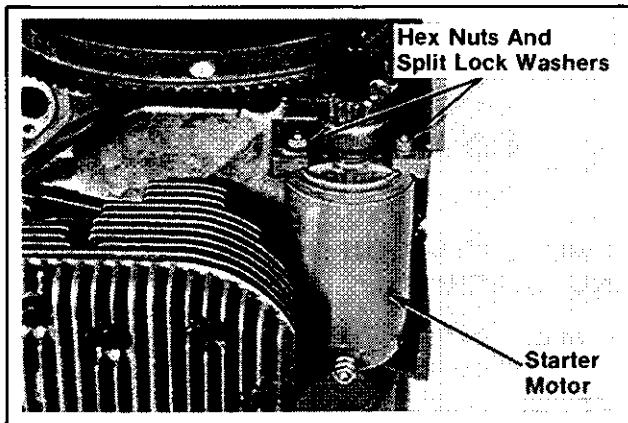

Figure 9-20. Removing Electric Starter.

## REMOVE GRASS SCREEN, FLYWHEEL, AND FAN

**CAUTION:** Always use the flywheel strap wrench to hold the flywheel when loosening or tightening flywheel and fan retaining fasteners. Do not use any type of bar or wedge between fins of cooling fan, as the fins could become cracked or damaged.

Always use a puller to remove flywheel from crankshaft. Do not strike the crankshaft or flywheel, as these parts could become cracked or damaged.

Refer to Section 2, Special Tools for recommended tools.

1. Unsnap the grass screen from fan.
2. Hold the flywheel with the strap wrench (Tool No. NU-10357) and loosen the hex cap screw. Refer to Figure 9-21.

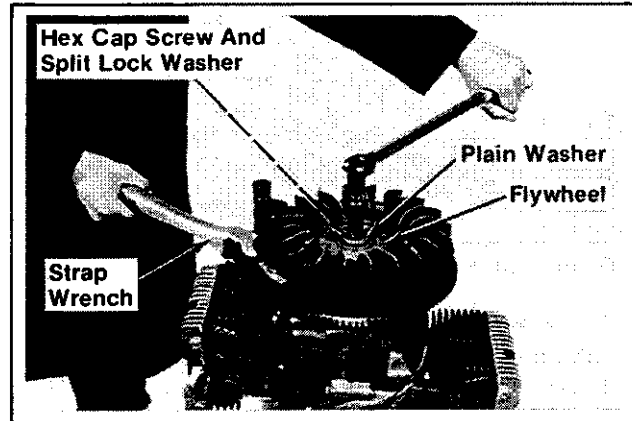

Figure 9-21. Loosening Flywheel Fastener.

Remove the hex cap screw, split lock washer, and plain washer. Refer to Figure 9-22.

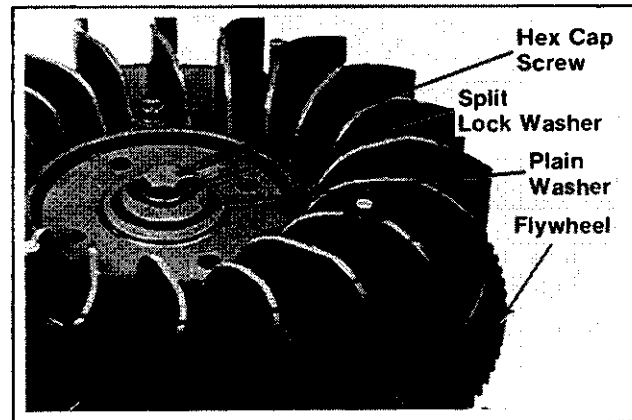

Figure 9-22. Removing Flywheel Fastener.

3. Remove the flywheel from crankshaft using a puller (Tool No. NU-3226). Refer to Figure 9-23.

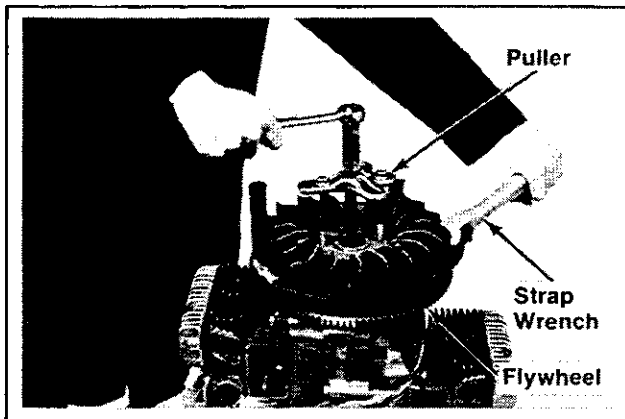

Figure 9-23. Removing Flywheel Using A Puller.

4. If necessary remove the hex flange screws, spacers, and fan. Refer to Figure 9-24.

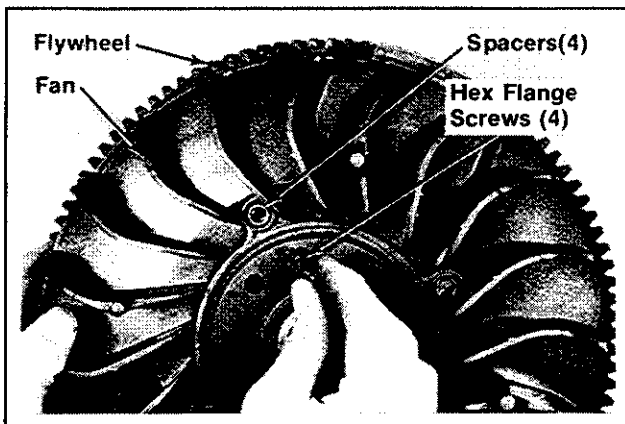

Figure 9-24. Removing Fan From Flywheel.

**WARNING: Ignition Magnet Is Not Removable or Serviceable!**



Do not attempt to remove the ignition magnet from flywheel. Loosening or removing the magnet mounting screws could cause the magnet to come loose and be thrown from the engine causing severe injury. Replace the flywheel if magnet is damaged.

**REMOVE STATOR**

1. Remove the self-tapping screws and stator. Refer to Figure 9-25.

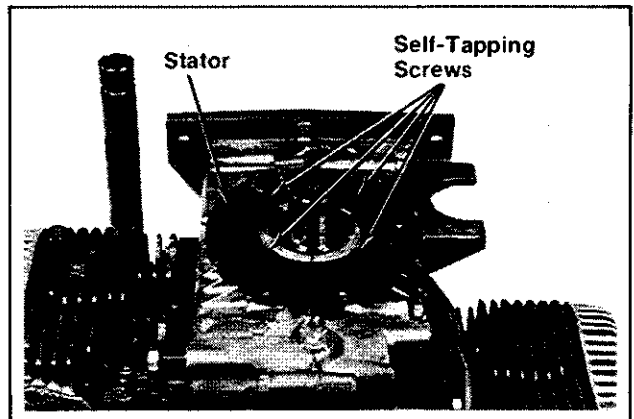

Figure 9-25. Removing Stator.

**IDENTIFY ENGINE SIDES**

To ensure proper reassembly, it is necessary to identify the engine sides and various other engine components. Refer to Figure 9-26. The #1 side of engine has the cylinder barrel closest to the flywheel end of crankshaft. The #2 side of engine has the cylinder barrel closest to the PTO end of crankshaft.

**CAUTION:** To prevent damage to the engine crankcase and other components, do not mark using a metal stamp.

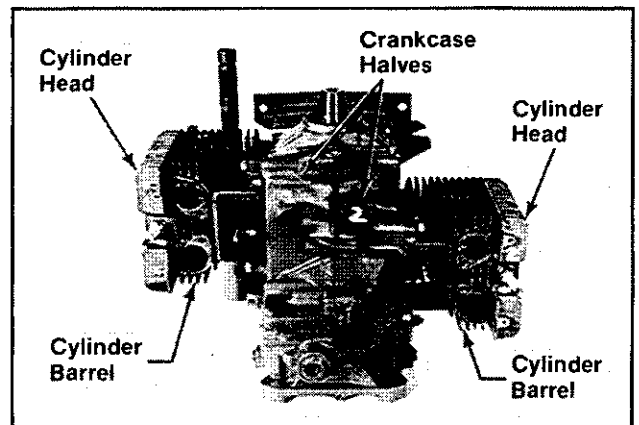

Figure 9-26. Identifying Engine Sides.

1. With a marking pen, paint, or chalk, mark the crankcase halves and cylinder heads as #1 side and #2 side.
2. The cylinder barrels are already identified as #1 or #2 by a mark stamped near the valve cover/breather gasket surface.
3. Identify other engine components, such as the valve, pistons, connecting rods and rod caps, and valve tappets, prior to removal or disassembly.

## REMOVE SPARK PLUGS AND CYLINDER HEADS

1. Remove the spark plugs from cylinder heads.
2. Remove the hex cap screws, plain washers, cylinder heads, and gaskets. Refer to Figure 9-27.

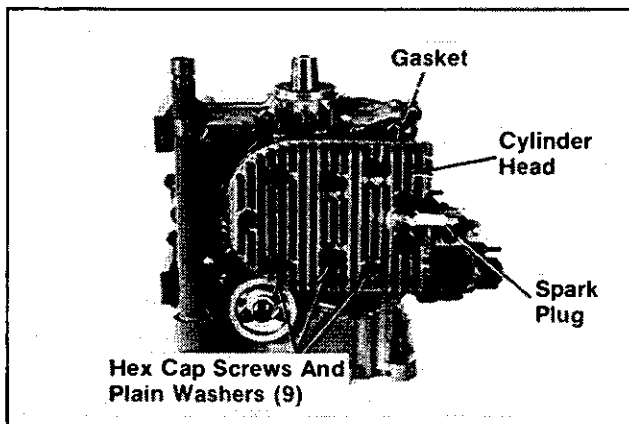

Figure 9-27. Removing Spark Plugs And Cylinder Heads.

## REMOVE CYLINDER BARRELS

1. Remove the hex nuts and plain washers using the barrel wrench (Tool No. NU-11797). Refer to Figure 9-28.

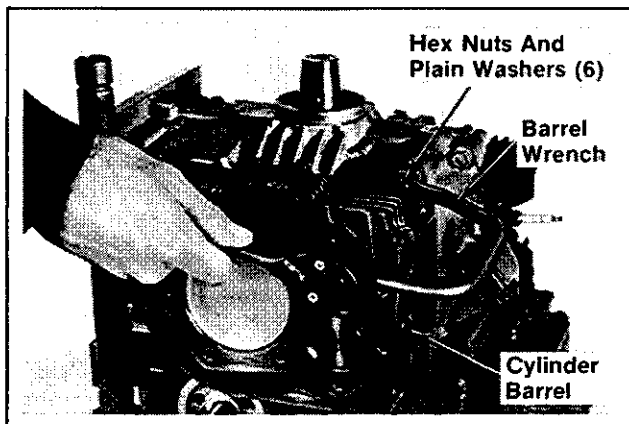

Figure 9-28. Removing Cylinder Barrel Fasteners.

2. Using a soft-faced hammer, carefully tap the cylinder barrels between the intake and exhaust ports to break the seal between cylinder barrels and crankcase.

3. Support the weight of barrels with hands, and carefully pull the barrels from the studs and pistons. Refer to Figure 9-29.

**CAUTION:** To prevent damage to pistons or connecting rods when removing barrels, make sure the cylinder barrels and connecting rods are supported at all times. Do not allow the pistons or connecting rods to strike the edges of crankcase.

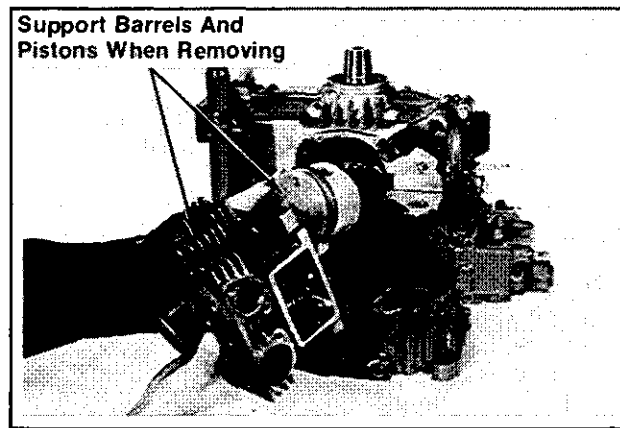

Figure 9-29. Removing Cylinder Barrels.

4. Thoroughly remove the sealant from the mating surfaces of crankcase and cylinder barrels.

**CAUTION:** The use of a gasket-removing solvent is recommended. Do not scrape the surfaces with a metal putty knife or similar tool. Scratching the mating surfaces will cause leaks.

**NOTE:** Disassembly procedures after cylinder barrel removal should be accomplished with engine on its side. Refer to Figure 9-31.

## REMOVE VALVES

1. With a marking pen or paint, mark the valves as coming from the #1 or #2 cylinder barrel. Exhaust valves are already identified with an "EX" stamp on the valves.
2. Compress the valve springs with a valve spring compressor and remove keepers. Refer to Figure 9-30.

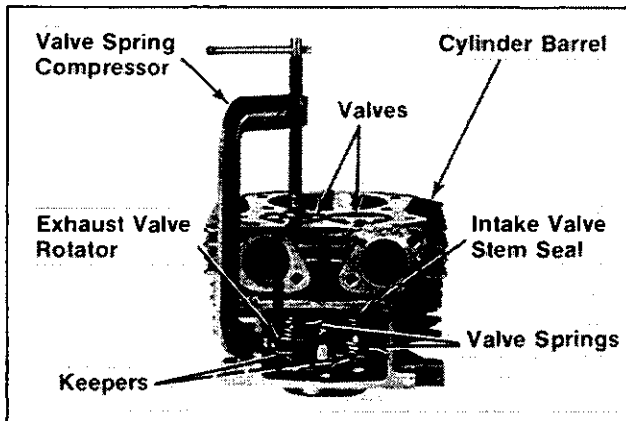

Figure 9-30. Removing Valves.

3. Remove the valve spring compressor; then remove valves, lower intake valve spring retainers, exhaust valve rotators, and valve springs.
4. Remove the intake valve seals from valve guides.

### REMOVE PISTONS FROM CONNECTING RODS

1. With a marking pen or paint, mark the pistons and connecting rods as #1 side and #2 side. Refer to Figure 9-31.

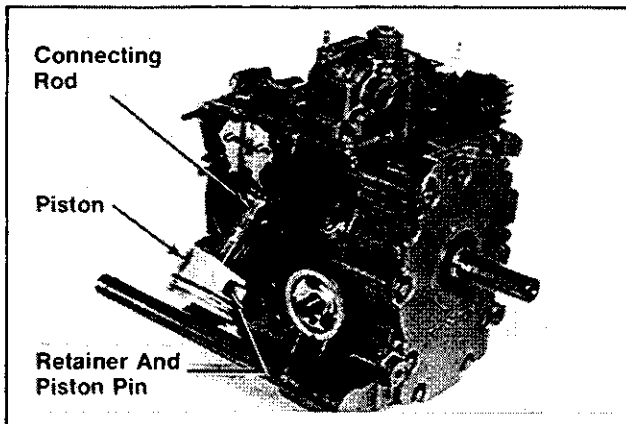

Figure 9-31. Removing Pistons.

2. Remove the piston pin retainers, piston pins, and pistons.

### REMOVE PISTON RINGS

1. Remove the top and center compression rings using a ring expander tool. Refer to Figure 9-32.

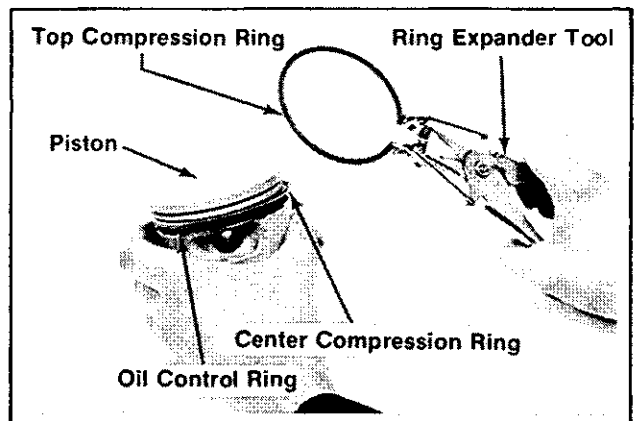

Figure 9-32. Removing Piston Rings.

2. Remove the oil control ring rails; then remove rails spacer.

### REMOVE OIL FILTER ADAPTER

1. Remove the hex socket head screws, oil filter adapter, and gasket. Refer to Figure 9-33.

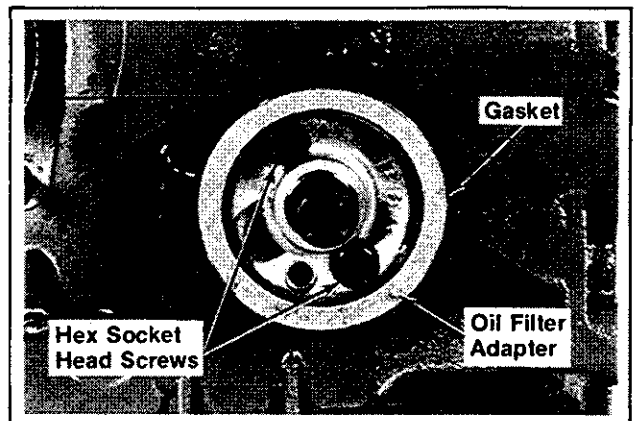

Figure 9-33. Removing Oil Filter Adapter.

### REMOVE OIL PAN, OIL PRESSURE RELIEF VALVE, OIL PICKUP SCREEN, AND OIL SEAL.

1. Remove the hex flange screws and oil pan. Refer to Figure 9-34.

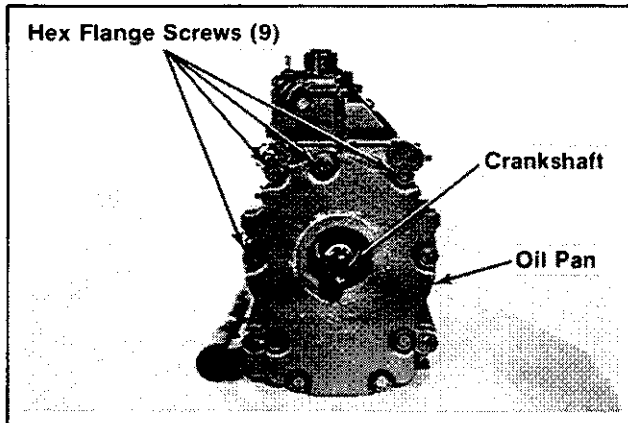

Figure 9-34. Removing Oil Pan.

2. Remove the oil pressure relief valve spring, steel ball, and sleeve. Refer to Figure 9-35.

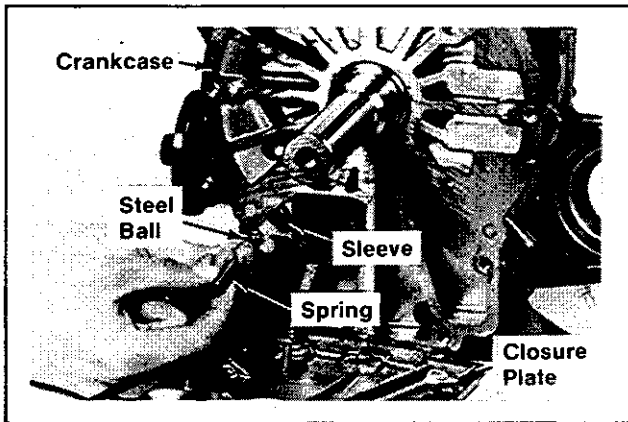

Figure 9-35. Removing Oil Pressure Relief Valve.

3. Remove the self-tapping screws and oil pickup screen from oil pan. Refer to Figure 9-36.

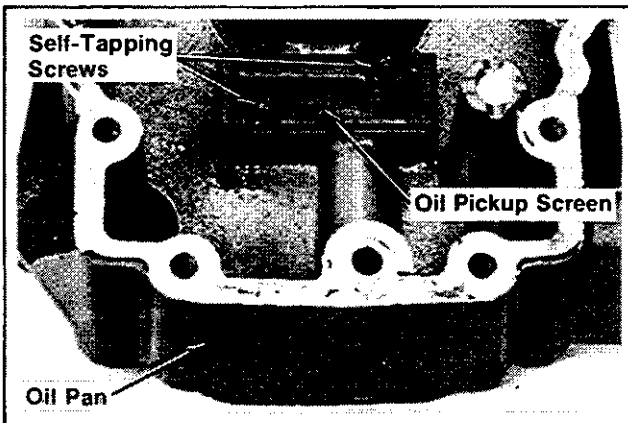

Figure 9-36. Removing Oil Pickup Screen.

4. Remove the oil seal from oil pan.

## SPLIT THE CRANKCASE

1. Scribe a line across the camshaft bore plug and the #1 crankcase side. This line is used to align the plug on reassembly. Refer to Figure 9-37.

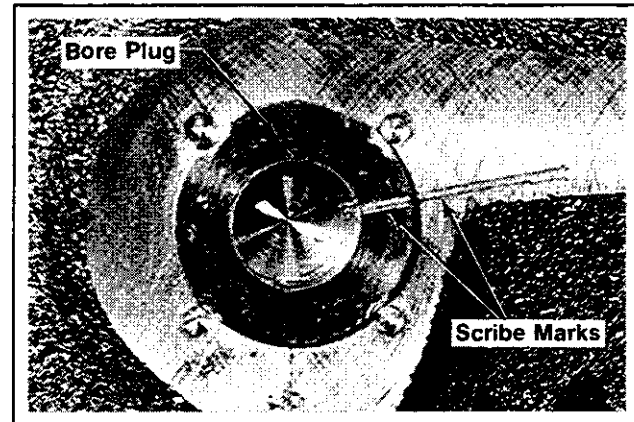

Figure 9-37. Camshaft Bore Plug.

2. Put a rubber band or tape around the tappet stems in the #2 crankcase side. This prevents the tappets from falling into the #1 side when the crankcase is split.
3. Remove the hex nuts, plain washers, and hex flange screws securing the crankcase halves together.
4. Lay the crankcase down so the #2 side is up. Locate the splitting notches in the seam of the crankcase. Pry the halves apart using the blade of a large screwdriver. Refer to Figure 9-38.

**CAUTION:** Insert the screwdriver only in the splitting notches. Do not pry on the gasket surfaces of crankcase as this can cause leaks.

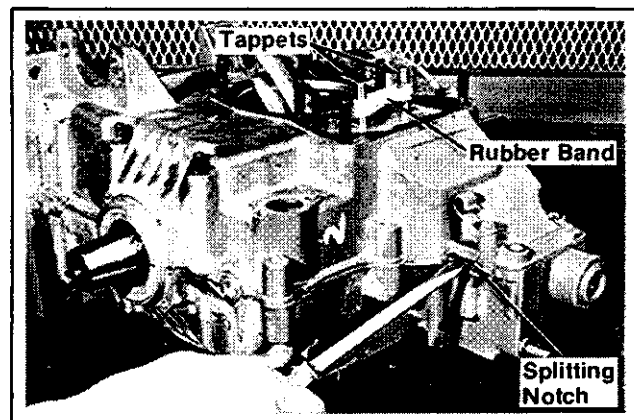

Figure 9-38. Splitting The Crankcase.



## REMOVE CAMSHAFT AND TAPPETS

1. Remove the camshaft and camshaft bore plug from the #1 crankcase side. Refer to Figure 9-39.

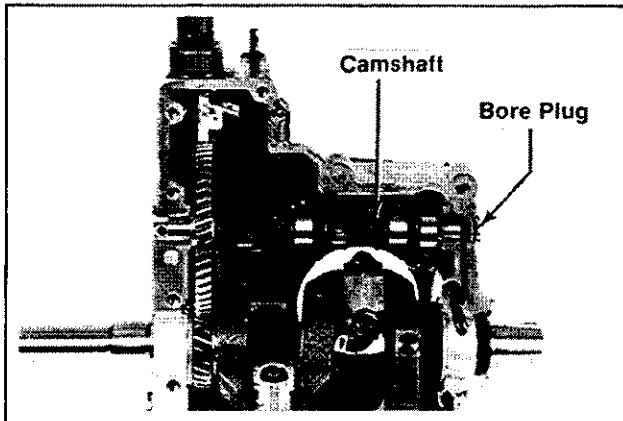

Figure 9-39. Removing The Camshaft And Camshaft Bore Plug.

2. With a marking pen or paint, mark the tappets according to crankcase side and as either intake or exhaust. Remove tappets from both crankcase sides. Refer to Figure 9-40.

NOTE: The intake valve tappet is closest to the flywheel side of crankcase. The exhaust valve tappet is closest to the PTO side of crankcase.

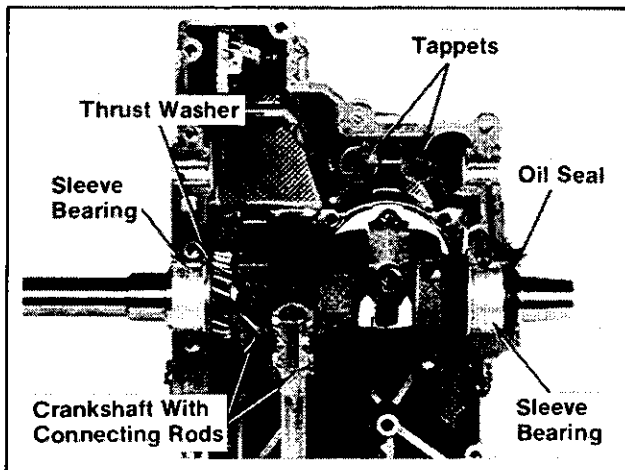

Figure 9-40. Removing Tappets, Crankshaft, Oil Seal, And Bearings

## REMOVE CRANKSHAFT, OIL SEAL, AND BEARINGS.

1. Remove the crankshaft with connecting rods, bearings, and oil seal from the #1 crankcase side. Refer to Figure 9-40.
2. Remove the oil seal from the flywheel end of crankshaft. Remove bearings and thrust washer from crankshaft.

## REMOVE CONNECTING RODS

1. With a marking pen or paint, mark the connecting rods and rod caps as #1 side and #2 side.
2. Remove the hex nuts, connecting rod caps, and connecting rods from crankshaft. Refer to Figure 9-41.

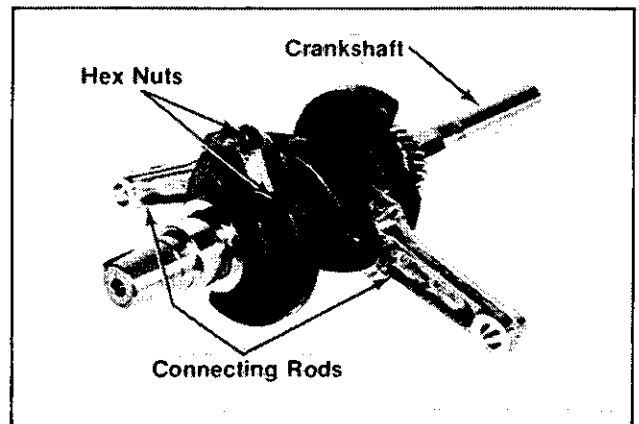

Figure 9-41. Removing Connecting Rods.

## REMOVE GOVERNOR GEAR AND CROSS SHAFT

1. Remove the governor stop pin and copper washer. Refer to Figure 9-42.

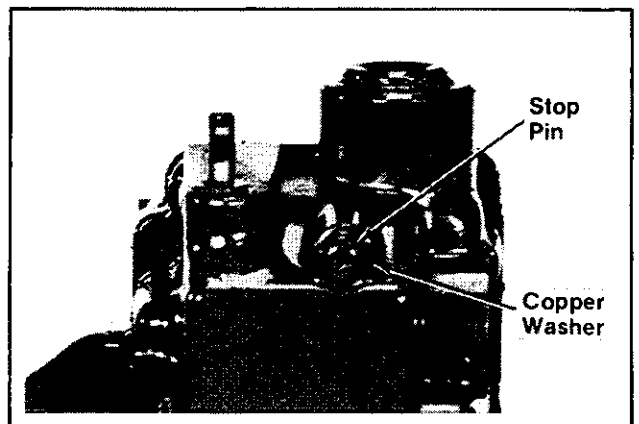

Figure 9-42. Removing Governor Stop Pin.

- Remove the governor gear from stub shaft. Refer to Figure 9-43.

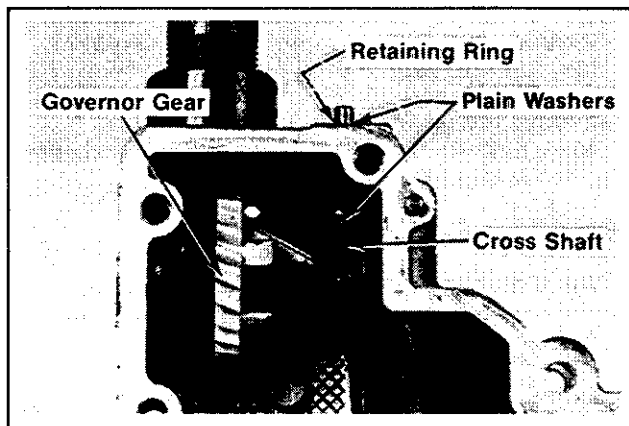

Figure 9-43. Removing Governor Gear.

- Remove the retaining ring, plain washers, and cross shaft.

## REMOVE OIL PUMP

NOTE: The oil pump rotors, shaft, and drive gear are virtually trouble-free and normally require little service. These parts should be removed only if service or replacement is necessary.

- Remove the self-tapping screws, cover, and pump rotors. Refer to Figures 9-44 and 9-45.

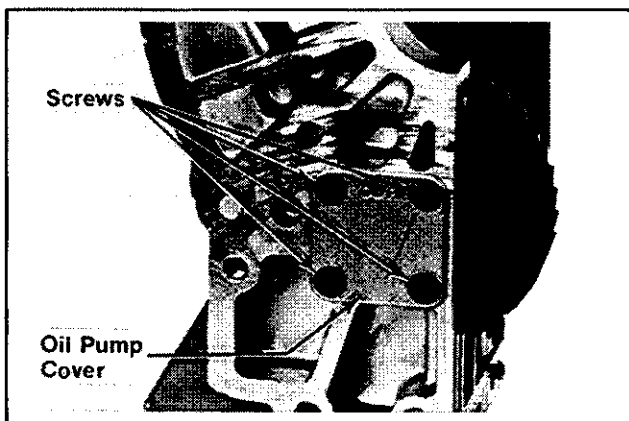

Figure 9-44. Removing Oil Pump Cover.

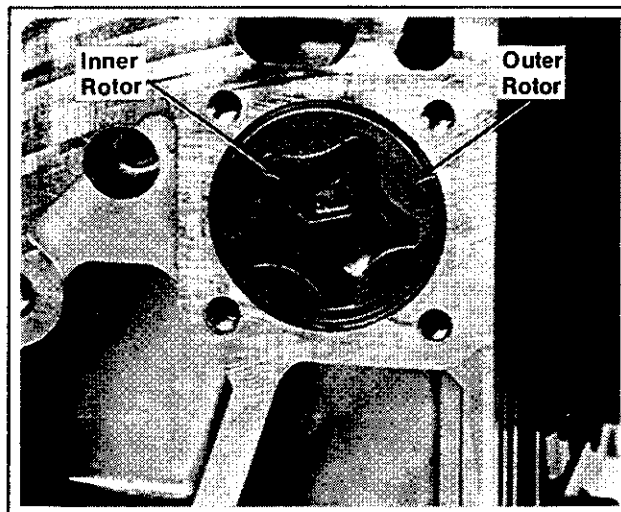

Figure 9-45. Removing Oil Pump Rotors.

- Using a small-diameter drift punch, drive the roll pin out of the pump drive gear and shaft. Remove shaft, drive gear, and shim spacer. Refer to Figure 9-46.

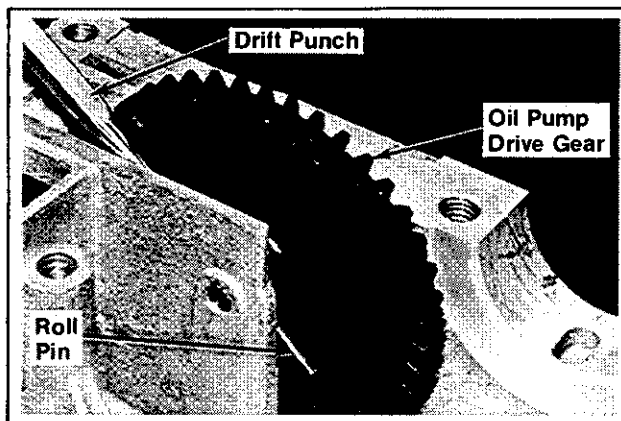

Figure 9-46. Removing Oil Pump Drive Gear.

# SECTION 10

## INSPECTION AND REPAIR/RECONDITIONING

All parts should be thoroughly cleaned — dirty parts cannot be accurately gauged or inspected properly for wear or damage. There are many commercially available cleaners that quickly remove grease, oil and grime accumulation from engine parts. If such a cleaner is used, *follow the manufacturers instructions carefully*, and make sure that all of the cleaner is removed before the engine is reassembled and placed in operation. Even small amounts of these cleaners quickly break down the lubricating properties of engine oils.

Refer to TP-2150, A Guide To Engine Rebuilding, for additional information. Also available is TP-2159, Measurement Guide, which you can use to record your inspection results.

### FLYWHEEL

#### Inspection

Inspect the flywheel for cracks, and the flywheel keyway for damage. Replace flywheel if cracked. Replace the flywheel, the crankshaft, and the key if flywheel key is sheared or the keyway damaged.

Inspect ring gear for cracks or damage. Kohler no longer provides ring gears as a servicable part. Replace flywheel if the ring gear is damaged.

### CYLINDER HEADS

#### Inspection

Blocked cooling fins often cause localized "hot spots" which can result in "blown" cylinder head gaskets. If gasket fails in area surrounding one of the retaining capscrews, high temperature gases can burn away portions of the aluminum alloy head. A cylinder head in this condition must be replaced.

If the cylinder heads appear in good condition, use a block of wood or plastic scraper to scrape away carbon deposits. Be careful not to nick or scratch the aluminum, especially in gasket seating area.

Cylinder heads should also be checked for flatness. Use a feeler gauge and a surface plate or piece of plate glass to make this check (refer to Figure 10-1). Cylinder head flatness should not vary more than **.003"**; if it does, replace the cylinder head (refer to Figure 10-1).

NOTE: Measure cylinder head flatness between each cap screw hole.

In cases where the head is warped or burned, it will also be necessary to replace the head screws. The high temperatures that warped or burned the head could have made the screws ductile which will cause them to stretch when tightened.

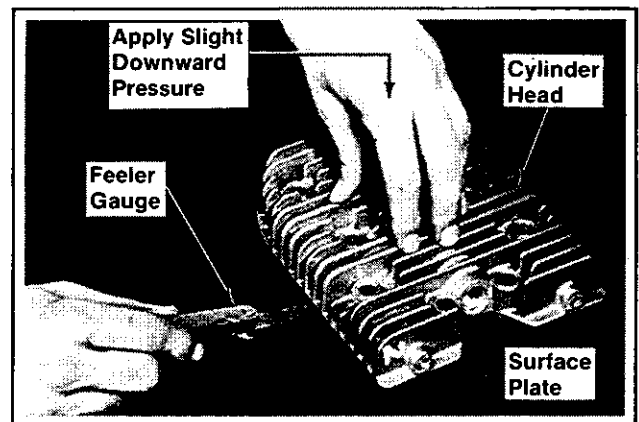

Figure 10-1. Checking Cylinder Head Flatness.

### CYLINDER BARRELS

#### Inspection And Reconditioning

Check all gasket surfaces to make sure they are free of gasket fragments. Gasket surfaces must also be free of deep scratches or nicks.

Check for scoring of the Cylinder Wall. Unburned fuel, in severe cases, can cause scuffing and scoring of the cylinder wall. As raw fuel seeps down the cylinder wall, it washes the necessary lubricating oils off the piston and cylinder wall so

that the piston rings make metal to metal contact with the wall. Scoring of the cylinder wall can also be caused by localized hot spots resulting from blocked cooling fins or from inadequate or contaminated lubrication.

If the cylinder bore is badly scored, excessively worn, tapered, or out of round, resizing is necessary. Use an inside micrometer to determine amount of wear (refer to "Specifications, Tolerances, And Special Torque Values", Section 1), then select the nearest suitable oversize of either .003", .010", .020", or .030". Resizing to one of these oversizes will allow usage of the available oversize piston and ring assemblies. Initially, resize using a boring bar, then use the following procedures for honing the cylinder:

### Honing

While most commercially available cylinder hones can be used with either portable drills or drill presses, the use of a low speed drill press is preferred as it facilitates more accurate alignment of the bore in relation to the crankshaft crossbore. Honing is best accomplished at a drill speed of about 250 RPM and 60 strokes per minute. After installing coarse stones in hone, proceed as follows.

1. Lower hone into bore and after centering, adjust so that the stones are in contact with the cylinder wall. Use of a commercial cutting-cooling agent is recommended.
2. With the lower edge of each stone positioned even with the lowest edge of the bore, start drill and honing process. Move hone up and down while resizing to prevent formation of cutting ridges. Check size frequently.

**NOTE:** Measure the piston diameter and resize the bore to the piston to obtain the specified running clearances. Keep in mind the temperatures caused by honing may cause inaccurate measurements. Make sure the barrel is cool when measuring.

3. When bore is within .0025" of desired size, remove coarse stones and replace with burnishing stones. Continue with burnishing stones until within .0005" of desired size and then use finish stones (220-280 grit) and polish to final size. A crosshatch should be observed if honing is done correctly. The crosshatch should intersect at approximately 23-33° off the horizontal. Too flat of an angle could cause the rings to skip and wear excessively, too steep of an angle will result in high oil consumption (refer to Figure 10-2).

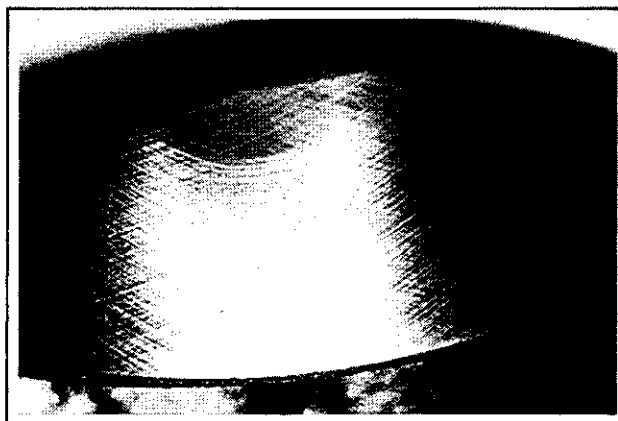

**Figure 10-2. Cylinder Bore Crosshatch After Honing.**

4. After resizing, check the bore for roundness, taper, and size. Use an inside micrometer, telescoping gauge, or bore gauge to take measurements (refer to Figure 10-3). The measurements should be taken at three locations in the cylinder—at the top, middle, and bottom. Two measurements should be taken (perpendicular to each other) at each of the three locations.

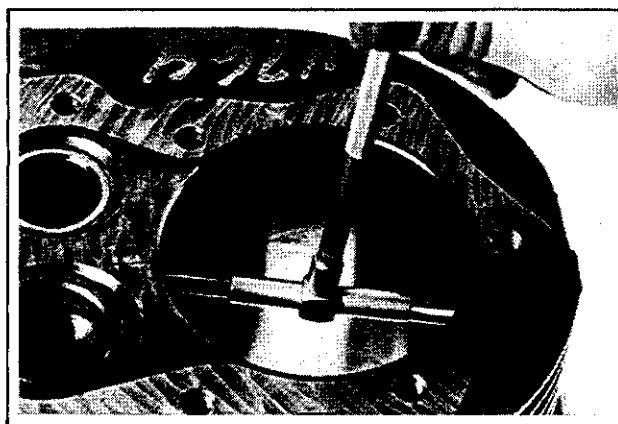

**Figure 10-3. Measuring Cylinder Bore.**

5. Thoroughly clean cylinder wall with soap and hot water. Use a scrub brush to remove all traces of boring/honing debris. Dry thoroughly and apply a light coat of SAE 10 oil to prevent rust.

### Measuring Piston-to-Bore Clearance

Before installing the piston into the cylinder bore, it is necessary that the clearance be accurately checked. This step is often overlooked, and if the clearances are not within specifications, generally engine failure will usually result.

**NOTE:** Do not use a feeler gauge to measure piston-to-bore clearance—it will yield inaccurate measurements. Use a micrometer.

The following procedures should be used to accurately measure the piston-to-bore clearance:

1. Use a micrometer and measure the diameter of the piston, 1/2" above bottom of piston skirt, perpendicular to the piston pin (refer to Figure 10-4).

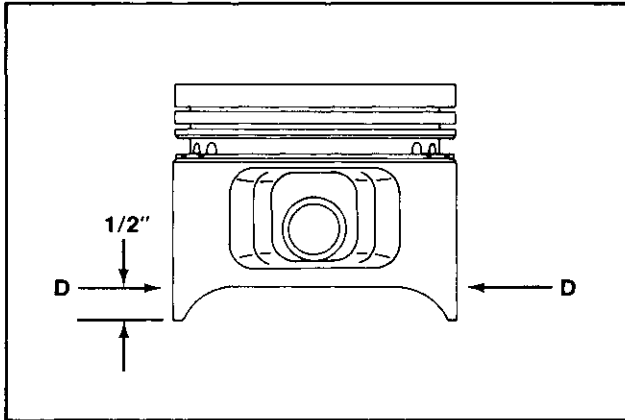

Figure 10-4. Measuring Piston Diameter (Style "D" Piston).

2. Use an inside micrometer, telescoping gauge, or bore gauge and measure the cylinder bore. Take the measurement approximately 2-1/2" below the top of the bore and perpendicular to the piston pin.

3. Piston-to-bore clearance is the difference between the bore and the piston diameter (step 2 minus step 1).

## VALVES

### Inspection And Service

Carefully inspect valve mechanism parts. Inspect valve springs and related hardware for excessive wear or distortion. Valve spring free height should be approximately **1.68" (1-11/16")**. Check valves and valve seat area or inserts for evidence of deep pitting, cracks, or distortion. Check clearance of valve stems in guides. Refer to Figure 10-5 for valve details and specifications.

Hard starting, or loss of power accompanied by high fuel consumption may be symptoms of faulty valves. Although these symptoms could also be attributed to worn rings, remove and check valves first. After removal, clean valve head, face, and stem with power wire brush and then carefully inspect for defects such as warped valve head, excessive corrosion, or worn stem end. Replace valves found to be in bad condition. A normal valve and valves in bad condition are shown in the accompanying illustrations.

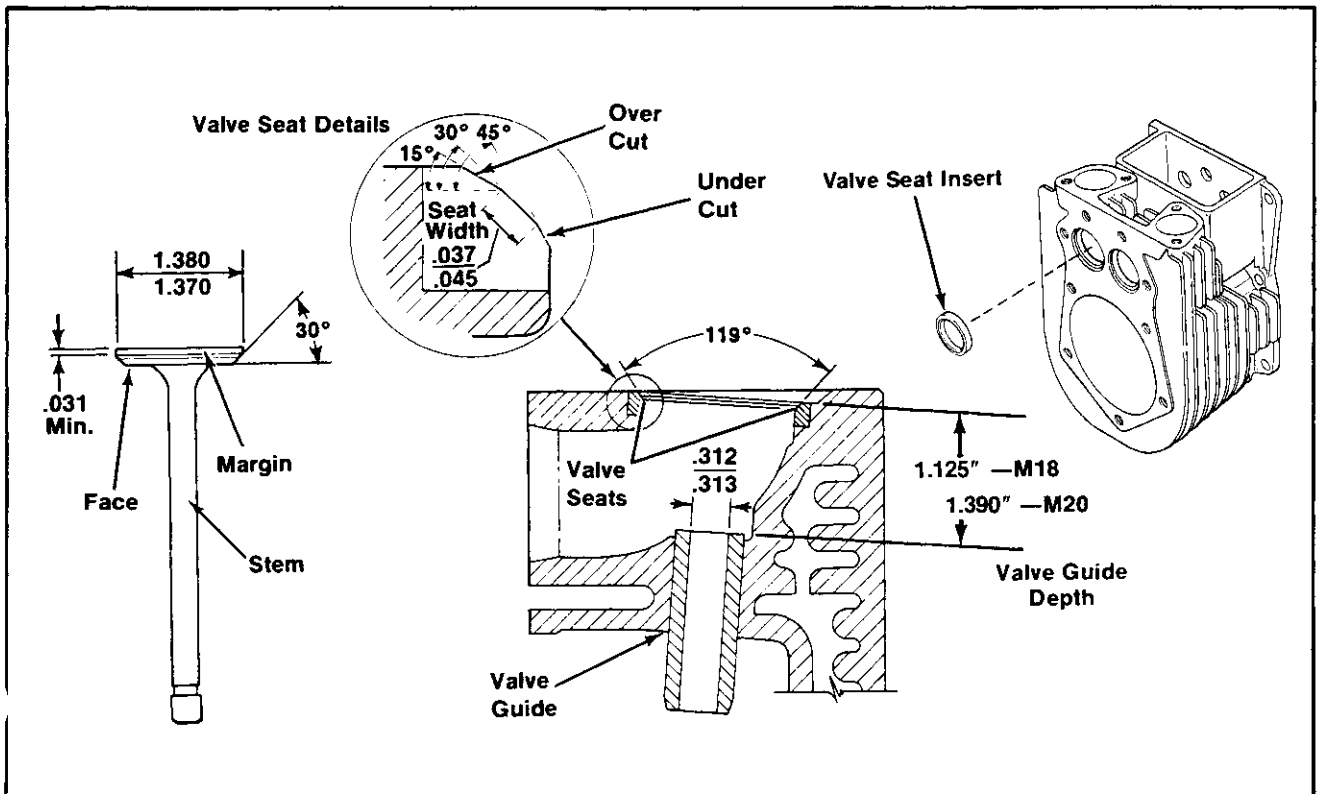
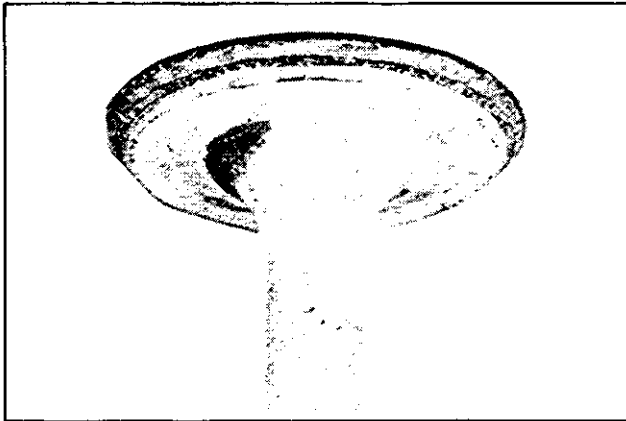
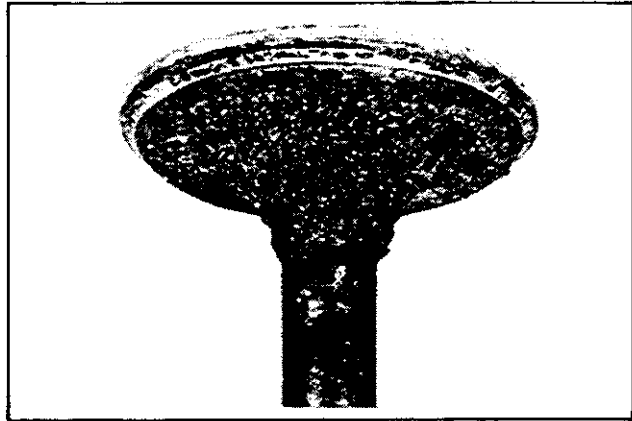

Figure 10-5. Valve Details.



**Normal:** Even after long hours of operation a valve can be reconditioned and reused if the face and margin are in good shape. If a valve is worn to where the margin is less than 1/32" do not reuse it. The valve shown was in operation for almost 100 hours under controlled test conditions.



**Gum:** Gum deposits usually result from using stale gasoline. This condition is often noted in applications where fuel is not drained out of tank during the off season. Gum is a prevalent cause of valve sticking. The cure is to ream the valve guides and clean or replace the valves, depending on their condition.

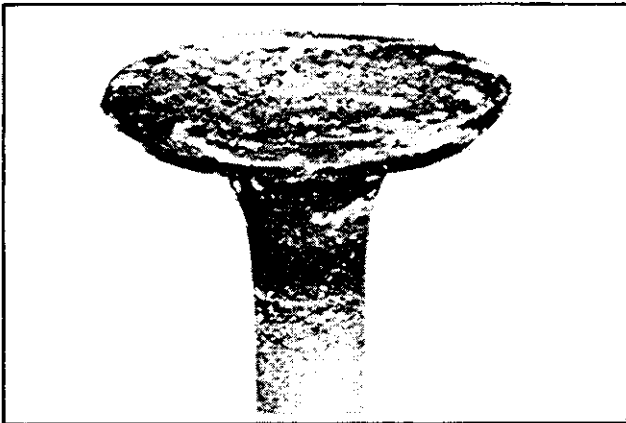

**Bad Condition:** The valve depicted here should be replaced. Note the warped head; margin damaged and too narrow. These conditions could be attributed to excessive hours or a combination of poor operating conditions.

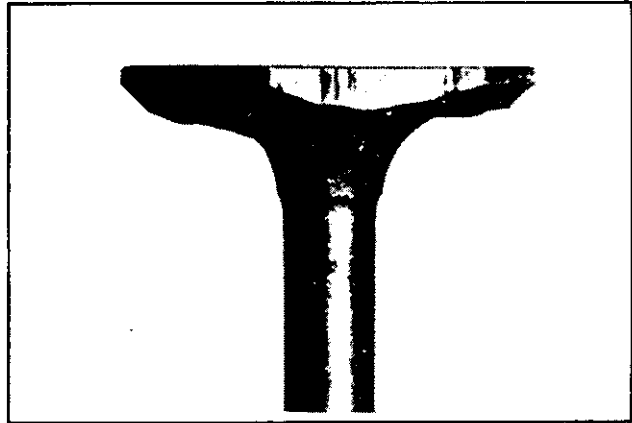

**Carbon Cut:** Excessive buildup of deposits in the combustion chamber may result in valve damage because deposits can become hard enough to cut the valve. Cleaning of the cylinder head at proper intervals could prevent such damage.

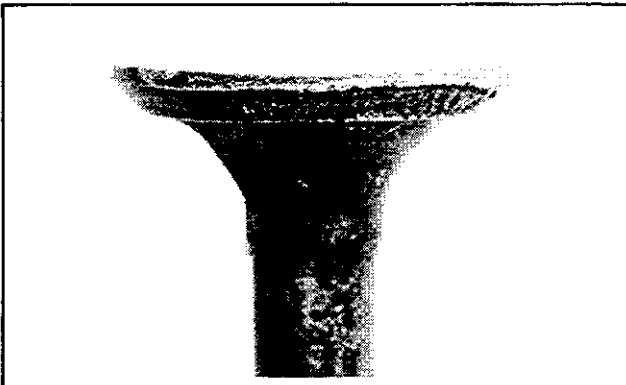

**Coking:** Coking is normal on intake valves and is not harmful. If the seat is good, the valve could be reused after cleaning.

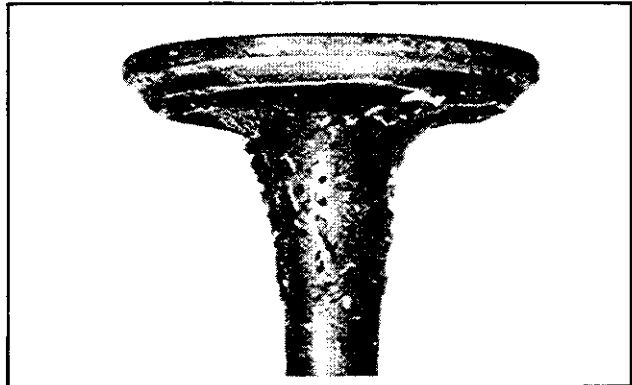

**Leakage:** A poor grind on face or seat of valve will allow leakage resulting in a burned valve on one side only.

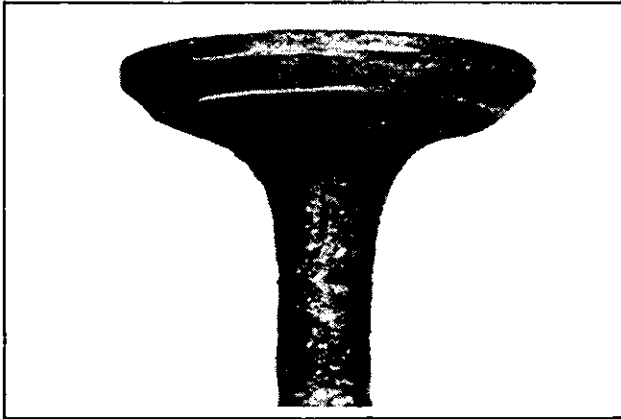

**Stem Corrosion:** Moisture in fuel or from condensation are the most common causes of valve stem corrosion. Condensation occurs from improper preservation during storage and when engine is repeatedly stopped before it has a chance to reach normal operating temperatures. Replace corroded valves.

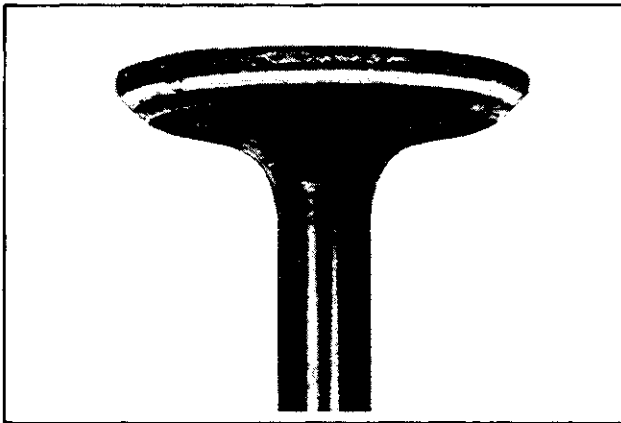

**Overheating:** An exhaust valve subject to overheating will have a dark discoloration in the area above the valve guide. Worn guides and faulty valve springs may cause this condition. Also check for clogged air intake, blocked fins, and lean fuel mixture when this condition is noted.

### Valve Guides

If a valve guide is worn beyond specifications, it will not guide the valve in a straight line. This may result in burnt valve faces or seats, loss of compression, and excessive oil consumption.

To check valve guide to valve stem clearance, thoroughly clean the valve guide and, using a split-ball gauge, measure the inside diameter. Then, using an outside micrometer, measure the diameter of the valve stem at several points on the stem where it moves in the valve guide. Use the largest stem diameter to calculate the clearance. If

the clearance exceeds **.005** on intake or **.007** on exhaust valve, determine whether the valve stem or the guide is responsible for the excessive clearance.

If the valve stem diameter is within specifications, then replace the valve guide.

### Remove Valve Guide

The valve guides are a tight press fit in the cylinder barrel. A valve guide removal tool is recommended to remove the guides (refer to Section 2, Special Tools). To remove valve guide, refer to Figure 10-6 and proceed as follows:

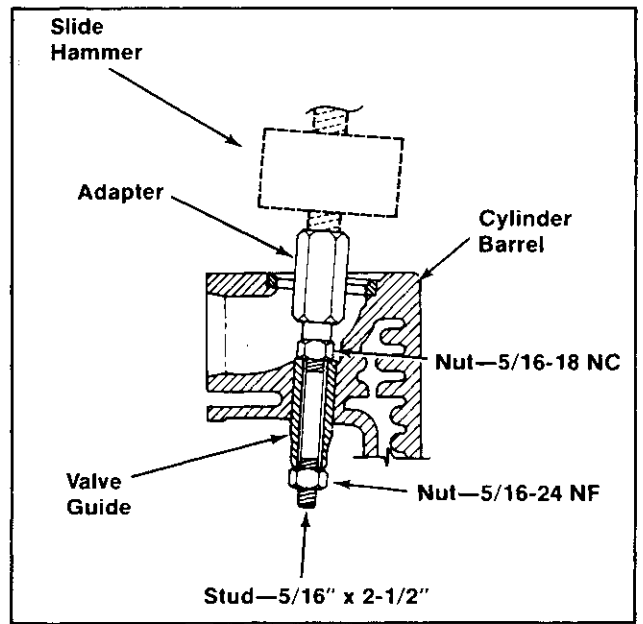

Figure 10-6. Pulling Valve Guide.

1. Install 5/16-18 NC nut on coarse threaded end of 2-1/2" long stud.
2. Insert other end of stud through valve guide bore and install 5/16-24 NF nut. Tighten both nuts securely.

**NOTE:** Valve guide must be held firmly by the stud assembly so that all slide hammer force will act on the guide.

3. Assemble the valve guide removal adapter to the stud and then the slide hammer to the adapter.
4. Use the slide hammer to pull the guide out.

### Install Valve Guide

To install valve guide, proceed as follows:

1. Make sure valve guide bore is clean and free of nicks or burrs.

- Using valve guide driver (Refer to Section 2, Special Tools), align and then press guide in until valve guide driver bottoms on depth gauge. Refer to Figure 10-7.

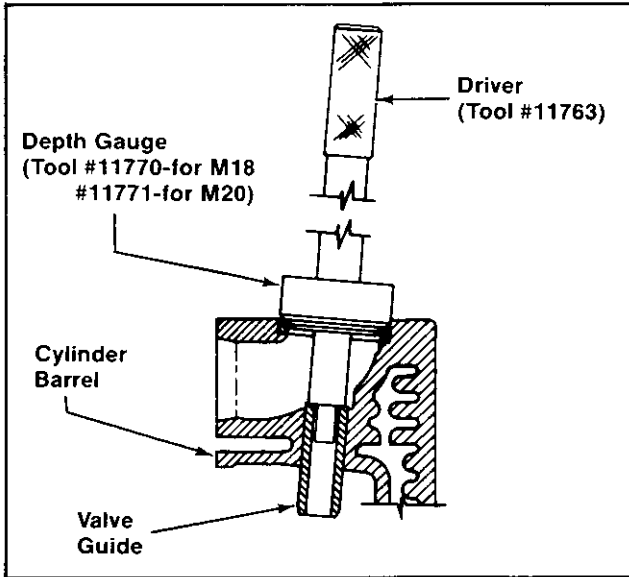

Figure 10-7. Installing Valve Guide.

- Valve guides are often slightly compressed during insertion. Use a piloted reamer (Refer to Section 2, Special Tools) and then a finishing reamer to resize the guide bore to .3125". Refer to Figure 10-8.

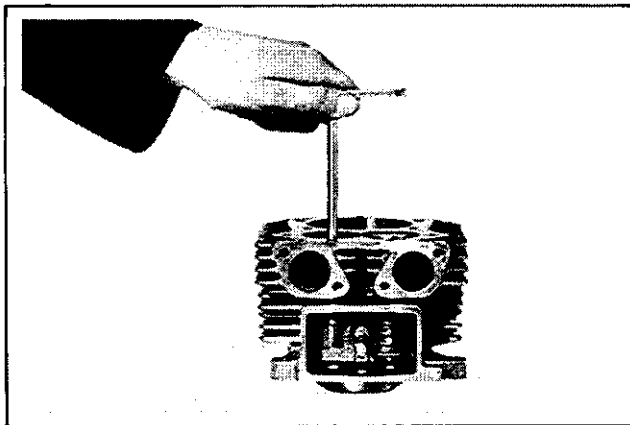

Figure 10-8. Reaming Valve Guide.

### Valve Seat Inserts

Intake valve seats are usually machined into the cylinder barrel, however, certain applications may specify hard alloy inserts. The exhaust valve seats are replaceable alloy inserts. If the seats become badly pitted, cracked, or distorted, the inserts must be replaced.

The inserts are a tight press fit in the cylinder barrel. A valve seat removal tool is recommended for this job (Refer to Section 2, Special Tools). Since insert removal causes loss of metal in the insert bore area, use only Kohler service replacement inserts which are slightly larger to provide retention in the cylinder barrel. Make sure new inserts are properly started and pressed into bore to prevent cocking of the insert.

### Remove Valve Seat Insert

To remove a valve seat insert, refer to Figure 10-9 and proceed as follows:

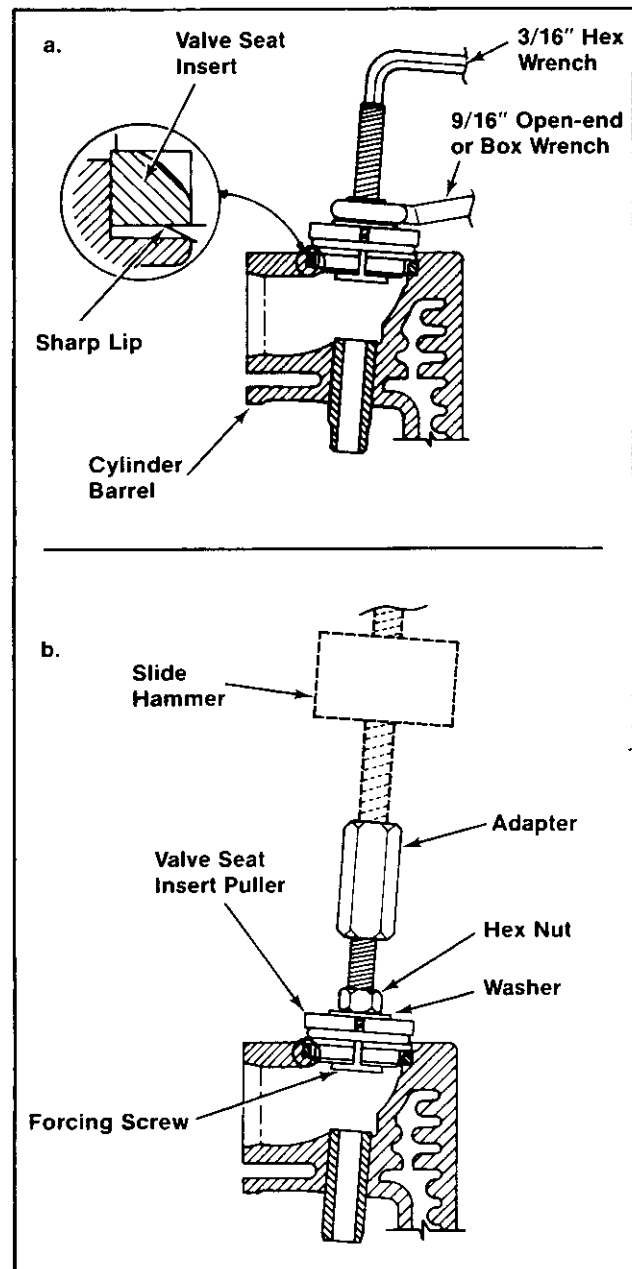

Figure 10-9. Pulling Valve Seat Insert.



1. Install valve seat puller on forcing screw and lightly secure with washer and nut.
2. Center the puller assembly on valve seat insert.
3. Hold forcing screw with a hex wrench to prevent turning and slowly tighten nut. (See Figure 10-9a.)
4. Continue to tighten nut until puller is tight against valve seat insert.
5. Assemble adapter to valve seat puller forcing screw and slide hammer to adapter. (See Figure 10-9b.)
6. Use slide hammer to remove valve seat insert.

### Install Valve Seat Insert

To install valve seat insert, proceed as follows:

1. Make sure valve seat insert bore is clean and free of nicks or burrs.
2. Align valve seat insert in counterbore. Using valve seat installer and driver (Refer to Section 2, Special Tools), press seat in until bottomed.
3. Use a valve seat cutter (see Figure 10-10) and cut seat to dimensions shown in Figure 10-5.

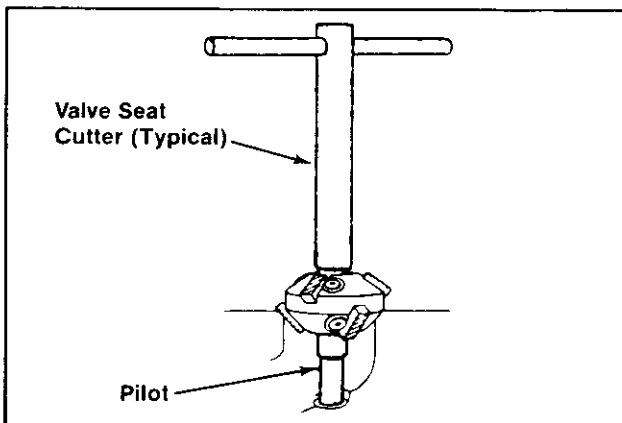

Figure 10-10. Typical Valve Seat Cutter.

Reground or new valves must be lapped in, to provide fit. Use a hand valve grinder with suction cup for final lapping. Lightly coat valve face with "fine" grade of grinding compound, then rotate valve on seat with grinder. Continue grinding until smooth surface is obtained on seat and on valve face. Thoroughly clean cylinder barrel in soap and hot water to remove all traces of grinding compound. After drying cylinder barrel, apply a light coating of SAE 10 oil to prevent rust.

### Valve Stem Seals

These engines use valve stem seals on the intake valves. Always use new seals when valves are removed from cylinder. Seals should also be replaced if deteriorated or damaged in any way. Never reuse old seals.

## PISTONS AND RINGS

### Identification

All Magnum MV engines use the new, "style D" pistons and matching piston rings. Style D pistons are identified by the installation direction identifier "Fly", which is stamped into the top of the piston, and by the rectangular recessed area around the piston pin. See Figure 10-11. Also, the piston pin bosses are thicker than other styles of similar pistons.

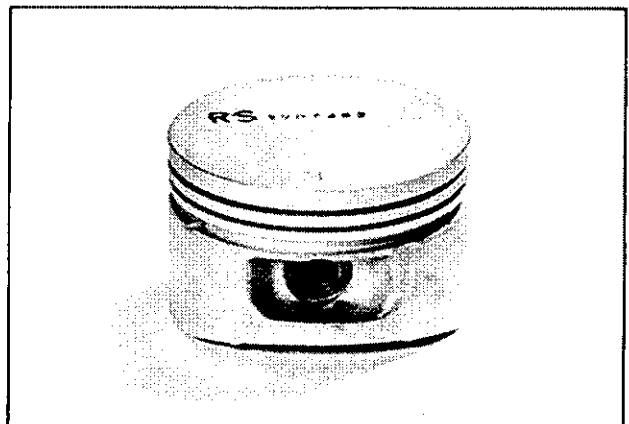

Figure 10-11. Style "D" Piston.

NOTE: The Posi-Lock connecting rods used with the style D pistons are narrower at piston pin end to accommodate the increased piston pin boss thickness. See "Posi-Lock Connecting Rods" elsewhere in this section.

### Inspection

Scuffing and scoring of pistons and cylinder walls occurs when internal temperatures approach the welding point of the piston. Temperatures high enough to do this are created by friction, which is usually attributed to improper lubrication, and/or overheating of the engine.

Normally, very little wear takes place in the piston boss-piston pin area. If the original piston and connecting rod can be reused after new rings are installed, the original pin can also be reused but new piston pin retainers are required. The piston

pin is included as part of the piston assembly—if the pin boss in piston, or the pin are worn or damaged, a new piston assembly is required.

Ring failure is usually indicated by excessive oil consumption and blue exhaust smoke. When rings fail, oil is allowed to enter the combustion chamber where it is burned along with the fuel. High oil consumption can also occur when the piston ring end gap is incorrect because the ring cannot properly conform to the cylinder wall under this condition. Oil control is also lost when ring gaps are not staggered during installation.

When cylinder temperatures get too high, lacquer and varnish collect on pistons causing rings to stick which results in rapid wear. A worn ring usually takes on a shiny or bright appearance. Scratches on rings and pistons are caused by abrasive material such as carbon, dirt, or pieces of hard metal.

Detonation damage occurs when a portion of the fuel charge ignites spontaneously from heat and pressure shortly after ignition. This creates two flame fronts which meet and explode to create extreme hammering pressures on a specific area of the piston. Detonation generally occurs from using fuels with too low of an octane rating.

Preignition or ignition of the fuel charge before the timed spark can cause damage similar to detonation. Preignition damage is often more severe than detonation damage—often a hole is quickly burned right through the piston dome. Preignition is caused by a hot spot in the combustion chamber from sources such as: glowing carbon deposits, blocked fins, improperly seated valves, or wrong spark plugs.

See Figure 10-12 for some common types of piston and ring damage.

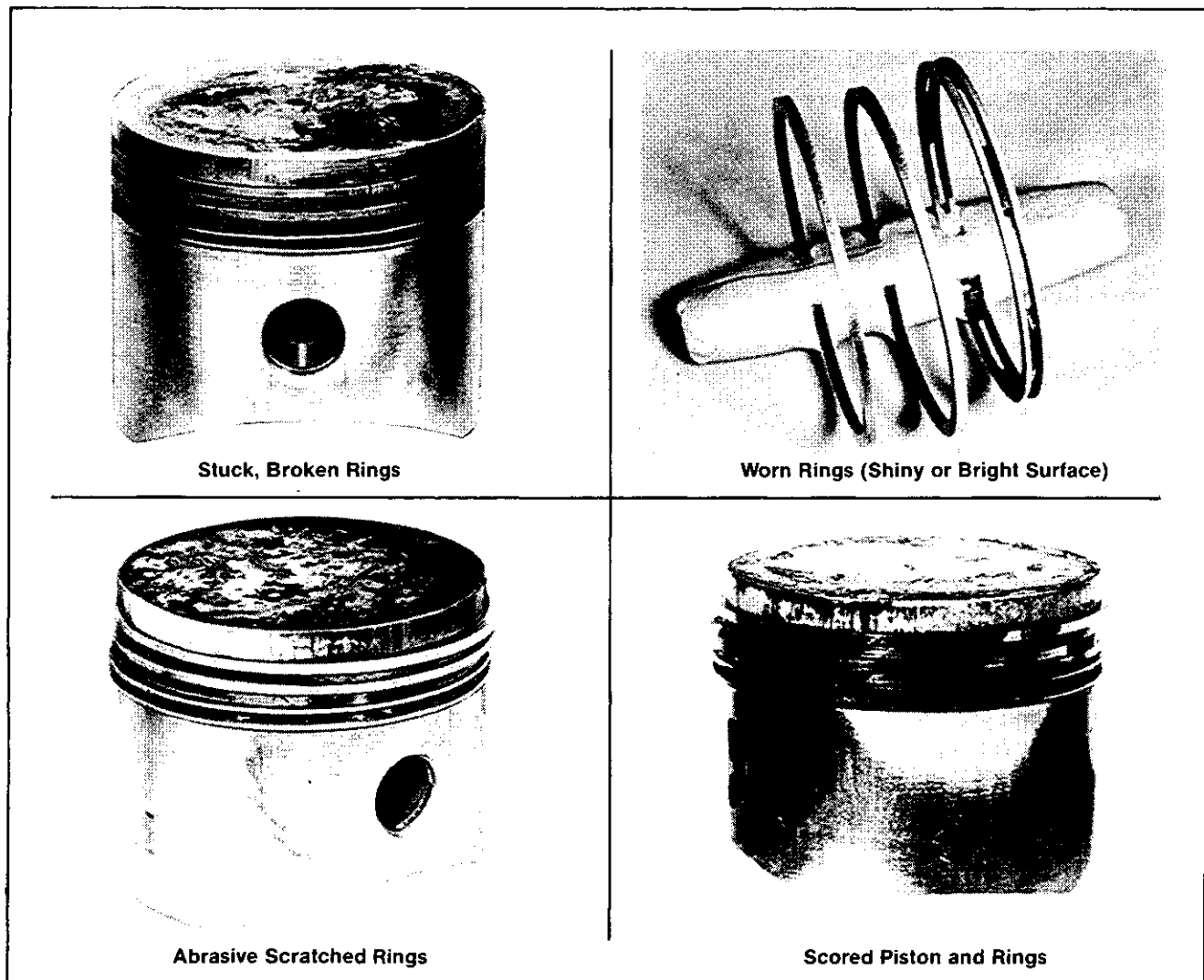

Figure 10-12. Common Types of Piston and Ring Damage.

## Service

Service replacement pistons are available in STD bore size, and in .003", .010", .020", and .030" oversizes. Replacement pistons include new piston ring sets and new piston pins.

Service replacement piston ring sets are also available separately for STD/.003" (same ring set for both sizes), .010", .020", and .030" oversized pistons. Always use new piston rings when installing pistons. Never reuse old rings.

The cylinder bore must be deglazed before service ring sets are used.

Some important points to remember when servicing piston rings:

1. If the cylinder block does not need reboring and if the old piston is within wear limits and free of score or scuff marks, the old piston may be reused.
2. Remove old rings and clean up grooves. Never reuse old rings.
3. Before installing new rings on piston, place top two rings, each in turn, in its running area in cylinder bore and check end gap (refer to Figure 10-13). This gap should be **.010"/.032"** in a used cylinder bore and **.010"/.023"** in a new cylinder bore.

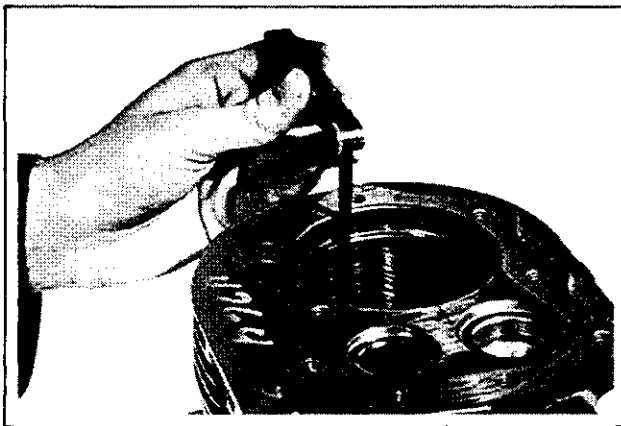

Figure 10-13. Measuring Piston Ring End Gap.

4. After installing the new compression (top and middle) rings on piston, check piston-to-ring side clearance. Maximum recommended side clearance is **.006"**. If side clearance is greater than **.006"**, a new piston must be used. Refer to Figure 10-14.

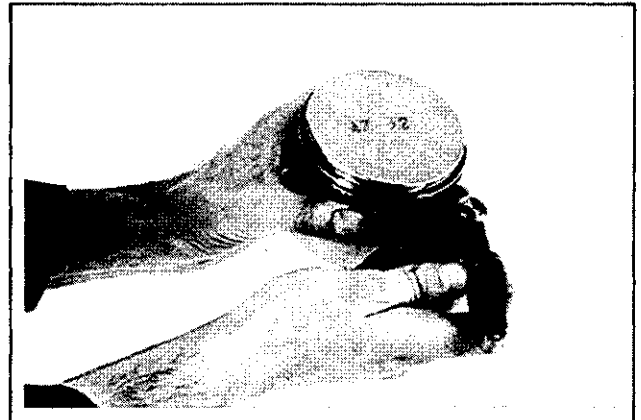

Figure 10-14. Measuring Piston Ring Side Clearance.

## Install Piston Rings

To install piston rings, proceed as follows:

NOTE: Rings must be installed correctly. Ring installation instructions are usually included with new ring sets. Follow instructions carefully. Use a piston ring expander to install rings. Install the bottom (oil control) ring first and the top compression ring last. Refer to Figure 10-15.

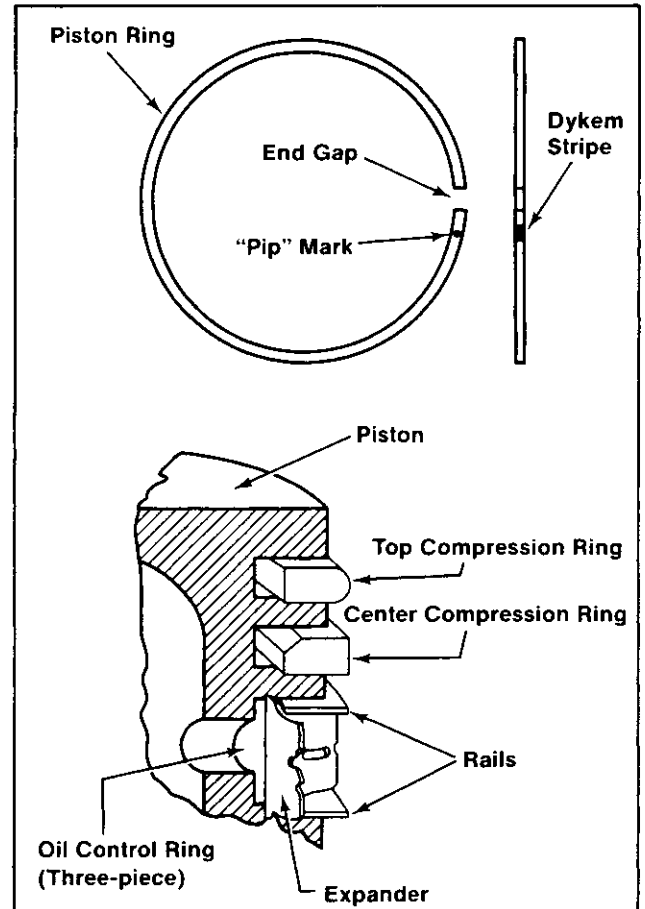

Figure 10-15. Piston Ring Installation.

1. Oil Control Ring (Bottom Groove): Install the expander and then the rails. Make sure the ends of expander are not overlapped.
2. Compression Ring (Center Groove): Install the beveled ring using a piston ring installation tool. Make sure the "pip" mark is up and the PINK dykem stripe is to the left of end gap.
3. Compression Ring (Top Groove): Install the top ring using a piston ring installation tool. Make sure the "pip" mark is up and the BLUE dykem stripe is to the left of end gap.

### POSI-LOCK CONNECTING RODS

Posi-Lock connecting rods are used in all Magnum MV16 and MV18 engines. The Posi-Lock design ensures accurate alignment of the rod and rod cap, and uniform lubrication. Once the rod and rod cap are locked together, shift is virtually impossible. Refer to Figure 10-16.

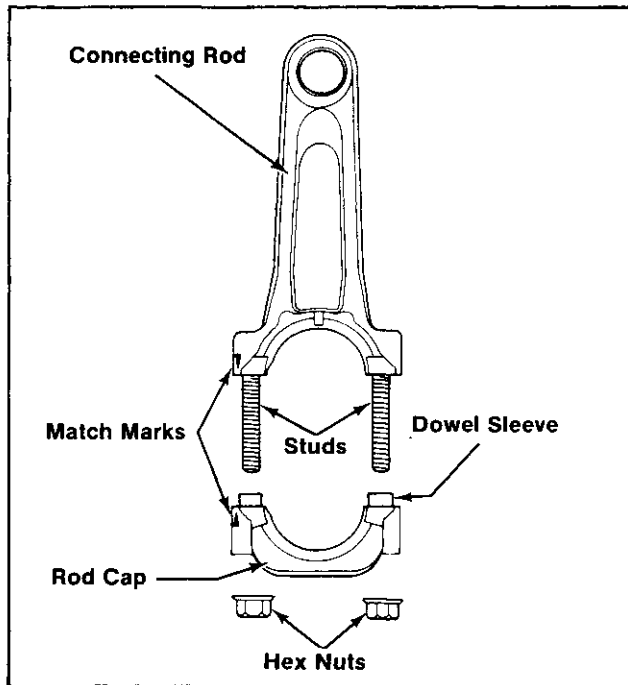

Figure 10-16. Posi-Lock Connecting Rods.

### Inspection And Service

Check bearing area (big end) for excessive wear, score marks, running and side clearances (Refer to Section 1, "Specifications, Tolerances, And Special Torque Values"). Replace rod and cap if scored or excessively worn.

Service replacement connecting rods are available in STD crankpin size and .010" undersize. The .010" undersized rod can be identified by the drilled hole located in the lower end of the rod shank (refer to Figure 10-17). Always refer to the appropriate parts information to ensure that correct replacements are used.

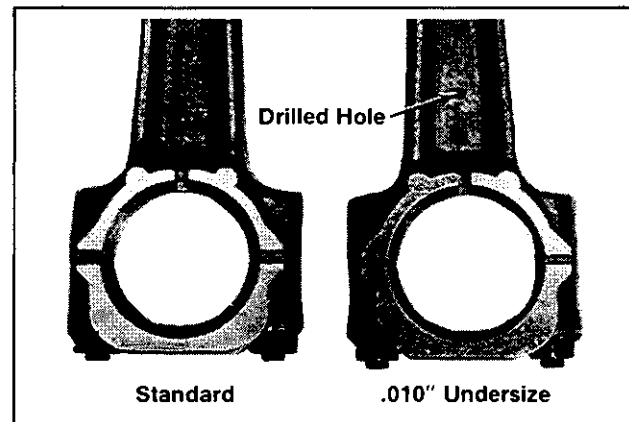

Figure 10-17. Standard and .010" Undersize Service Connecting Rods.

### CAMSHAFT AND CRANKSHAFT

#### Inspection and Service

Inspect the gear teeth on both the crankshaft and camshaft. If the teeth are badly worn, chipped, or some are missing, replacement of the damaged components will be necessary.

Also, inspect the crankshaft bearings for scoring, grooving, etc. Do not replace bearings unless they show signs of damage or are out of running clearance specifications. If crankshaft turns easily and noiselessly, and there is no evidence of scoring, grooving, etc., on the races or bearing surfaces, the bearings can be reused.

Check crankshaft keyways. If worn or chipped, replacement of the crankshaft will be necessary. Also inspect the crankpin for score marks or metallic pickup. Slight score marks can be cleaned with crocus cloth soaked in oil. If wear limits, as stated in "Specifications and Tolerances" are exceeded, it will be necessary to either replace the crankshaft or regrind the crankpin to .010" undersize. If reground, a .010" undersize connecting rod (big end) must then be used to achieve proper running clearance. Measure the crankpin for size, taper, and out-of-round.

NOTE: If the crankpin is reground, visually check to insure that the fillet blends smoothly with the crankpin surface. Refer to Figure 10-18.

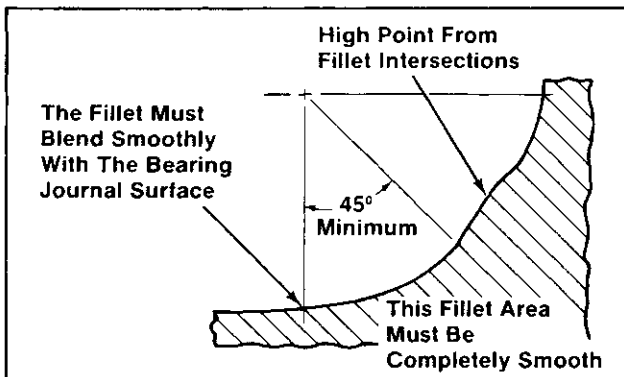

Figure 10-18. Crankpin Fillets.

## OIL PUMP

### Inspection And Service

Check oil pump gear for any cracked, chipped, or badly worn teeth. Replace gear if any of these problems exist. See Figure 10-19 for oil pump gear removal.

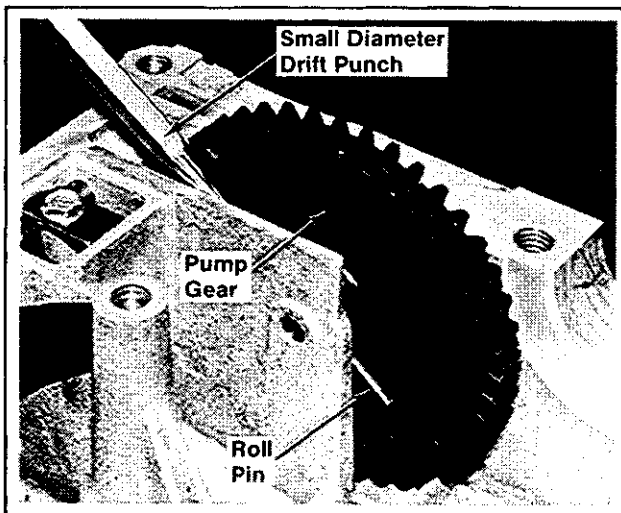

Figure 10-19. Removing The Oil Pump Gear.

Check oil pump relief valve ball, seat and spring (refer to Figure 10-20). Ball and seat should be free of nicks or burrs. Check spring for wear or distortion. Spring free length should be approximately .992". Replace spring if distorted or worn.

NOTE: An oil relief valve repair kit is available which contains a new spring, check ball and sleeve. Refer to your parts manual for correct kit part number.

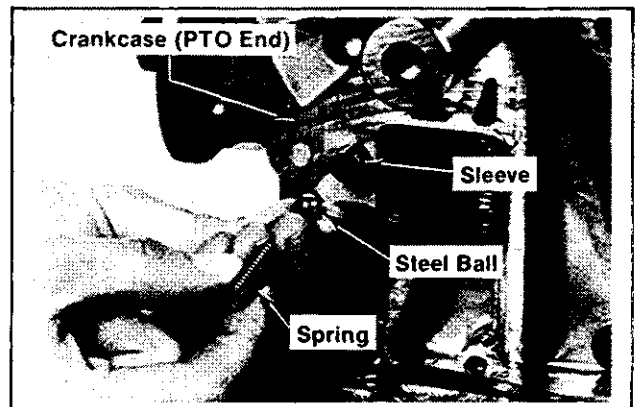

Figure 10-20. Oil Pressure Relief Valve.

## GOVERNOR GEAR

### Inspection

Inspect the governor gear teeth. Look for any evidence of worn, chipped, or cracked teeth. If one or more of these problems is noted, replace the governor gear.

# SECTION 11

## REASSEMBLY

The following sequence is suggested for complete engine reassembly. This procedure assumes that all components are new or have been reconditioned, and all component subassembly work has been completed. This procedure may have to be varied slightly to accommodate options or special equipment.

**CAUTION:** Make sure the engine is assembled using all specified torque values, tightening sequences, and clearances. Failure to observe specifications could cause severe engine wear or damage.

Always use new gaskets.

1. Install oil pump.
2. Install cross shaft and governor gear.
3. Install connecting rods.
4. Install bearings and crankshaft.
5. Install tappets and camshaft.
6. Install camshaft bore plug and seal crankcase.
7. Install oil seal.
8. Install oil pickup screen, oil pressure relief valve, and oil pan.
9. Install oil seal.
10. Install oil filter adapter.
11. Install piston rings.
12. Install pistons in cylinder barrels.
13. Install cylinder barrels.
14. Measure valve-to-tappet clearance.
15. Install valves.
16. Install cylinder heads and spark plugs.
17. Install stator.
18. Install fan, flywheel, and grass screen.
19. Install electric starter.
20. Install bracket and ignition module.
21. Install fuel pump.
22. Install blower housing, cylinder head baffles, support baffle, and top baffle.
23. Install breather and valve cover.

24. Install rectifier-regulator and connect wiring.
25. Install carburetor, intake manifold, and external governor components.
26. Install air cleaner.
27. Install mufflers.
28. Install oil filter.

### INSTALL OIL PUMP

1. Install the shim spacer (next to support rib), oil pump drive gear (slotted end of gear hub towards spacer and rib), and oil pump drive shaft (through support rib and into pump cavity). Refer to Figures 11-1 and 11-3.

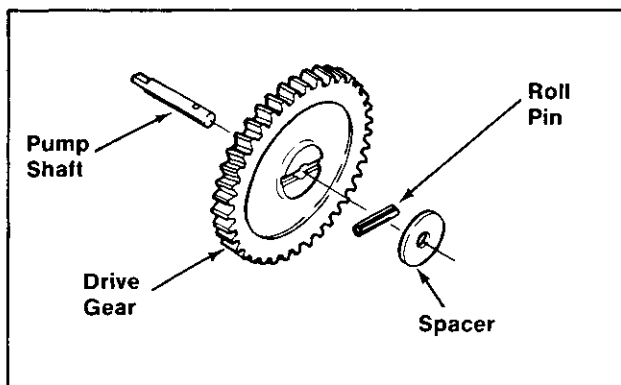

Figure 11-1. Installing Oil Pump Drive Gear.

2. Measure pump drive gear end play with a flat feeler gauge. Refer to Figure 11-2. Recommended end play is  $.010/.029$ ". Add one (1) additional shim spacer, if necessary, to bring end play within range.

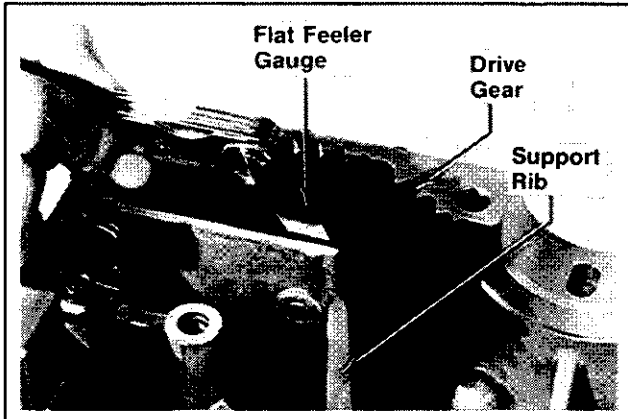

Figure 11-2. Measuring Oil Pump Drive Gear End Play.

3. Rotate the drive shaft and drive gear until hole in shaft is aligned with slot in gear hub.
4. Lubricate a new roll pin with grease. Drive the roll pin until it is flush with gear hub. Refer to Figure 11-3.

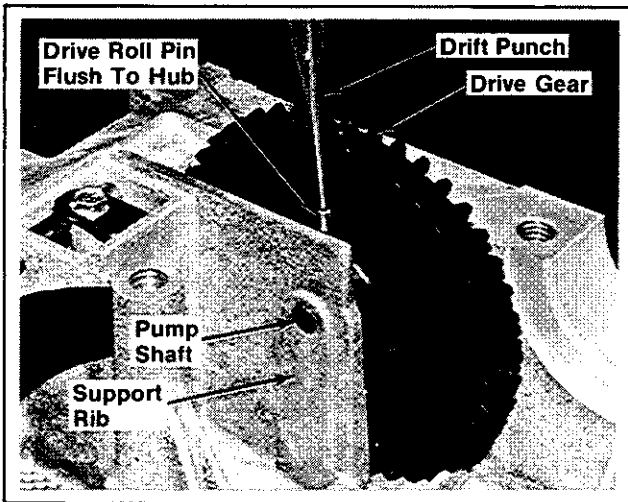

Figure 11-3. Securing Oil Pump Drive Gear To Shaft.

5. Lubricate the oil pump cavity with engine oil. Install inner and outer rotors. Refer to Figure 11-4.

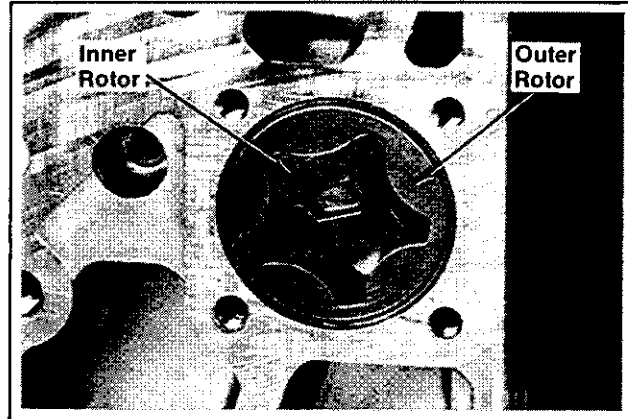

Figure 11-4. Installing Oil Pump Rotors.

6. Install the cover (side marked "OUT" away from crankcase) and self-tapping screws. Refer to Figure 11-5.

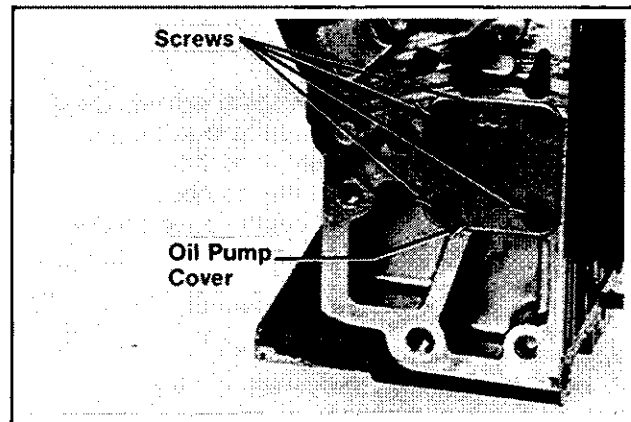

Figure 11-5. Installing Oil Pump Cover.

### INSTALL CROSS SHAFT AND GOVERNOR GEAR

1. Install the plain washer, cross shaft, plain washer, and retaining ring. Refer to Figure 11-6.

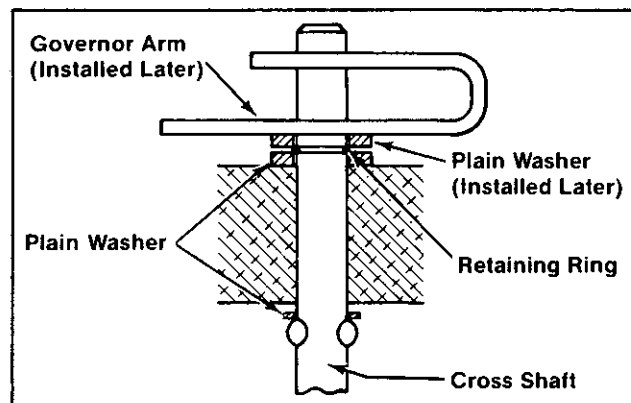

Figure 11-6. Installing Governor Cross Shaft.

2. Install the governor gear to stub shaft. Refer to Figure 11-7.

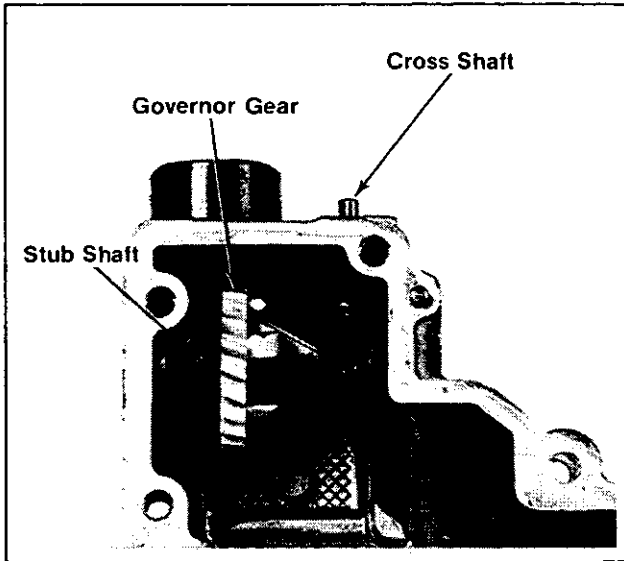

Figure 11-7. Installing Governor Gear.

3. Install the copper washer and governor stop pin. Refer to Figure 11-8.

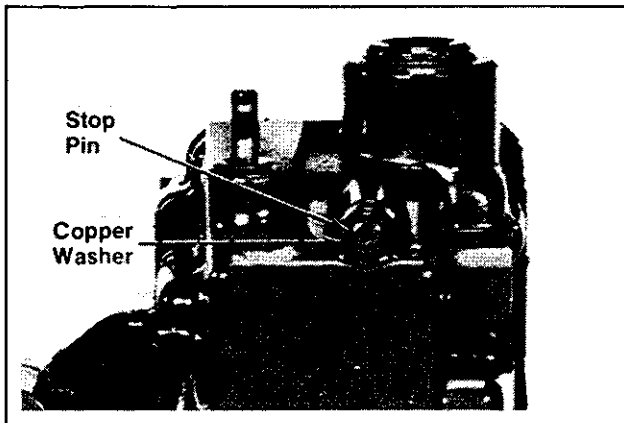

Figure 11-8. Installing Governor Stop Pin.

## INSTALL CONNECTING RODS

1. Lubricate the connecting rod journals and studs with engine oil and install connecting rods to crankshaft.

• **When Reinstalling Used Rods:** Install the #1 connecting rod to crankshaft journal closest to flywheel end of crankshaft. Install #2 connecting rod to the journal closest to PTO end of crankshaft.

2. Install the connecting rod caps. Make sure the match marks are aligned and the proper cap is reinstalled to each connecting rod. Refer to Figure 11-9.

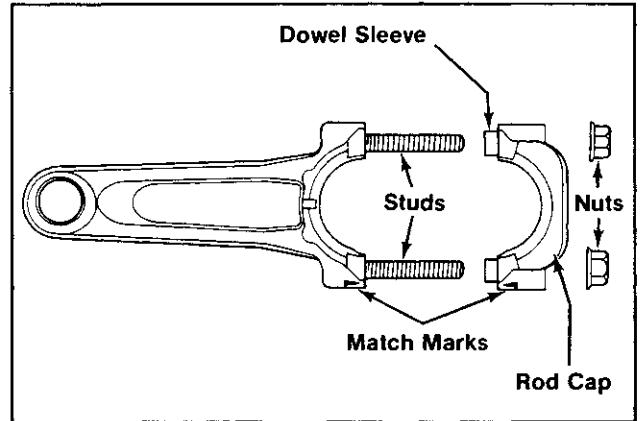

Figure 11-9. Installing Posi-Lock Connecting Rods.

3. Install the hex nuts and torque as follows:

	Torque
New Service Rod	140 in. lb.
Used/Reinstalled Rod	100 in. lb.

**CAUTION:** To prevent damage to the connecting rods and engine, do not overtorque—loosen—and retorque the hex nuts on Posi-Lock connecting rods. Torque the nuts, in increments, directly to the specified values.

## INSTALL BEARINGS AND CRANKSHAFT

1. Lubricate the crankshaft bearing journals with engine oil. Install the .130" thrust washer to PTO end of crankshaft. Refer to Figure 11-10.

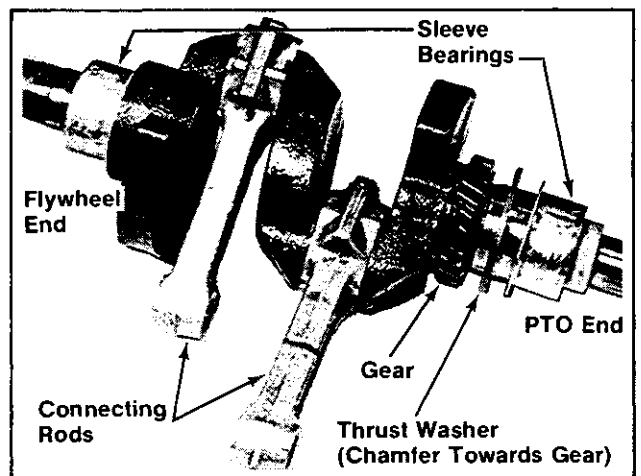

Figure 11-10. Installing Thrust Washer And Bearings To Crankshaft.



Make sure chamfer on thrust washer is towards crankgear.

2. Install the bearings to PTO and flywheel end of crankshaft.
3. Install the crankshaft with connecting rods and bearings into crankcase. Make sure the locating tab of PTO end sleeve bearing is positioned in notch in crankcase. Refer to Figure 11-11. The oil hole in flywheel end sleeve bearing must be aligned with the oil gallery in crankcase. Refer to Figure 11-12.

**CAUTION:** Improper positioning of bearings could result in engine failure due to lack of lubrication.

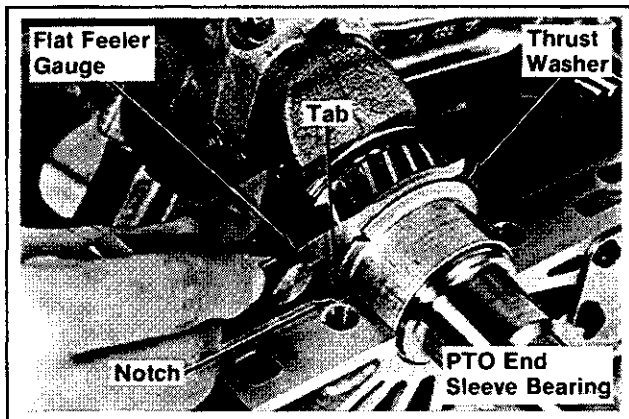

Figure 11-11. Position Of PTO End Bearing/Measuring Crankshaft End Play.

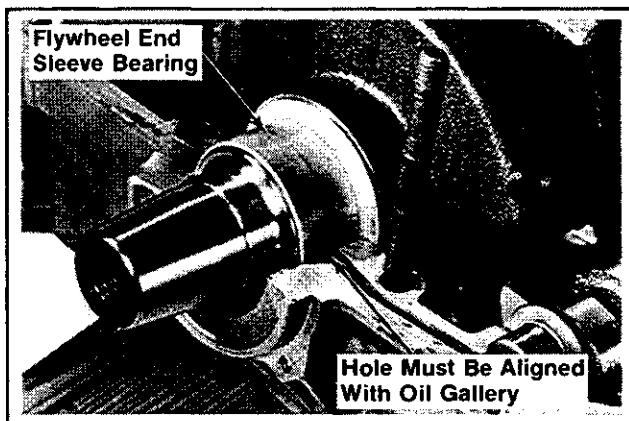

Figure 11-12. Position Of Flywheel End Bearing.

4. Measure the crankshaft end play with a flat feeler gauge. The recommended crankshaft end play is  $.002/.014$ ". Refer to Figure 11-11.

Exchange thrust washer, if necessary, to bring end play within range. Three sizes of thrust washers are available:  $.121$ ",  $.130$ " (STD), and  $.139$ ".

## INSTALL TAPPETS AND CAMSHAFT

1. Lubricate the stems of tappets with engine oil. Install the tappets into crankcase sides. Make sure that used tappets are reinstalled into the proper sides and positions (intake or exhaust) as marked during disassembly.

**NOTE:** The intake valve tappet is closest to the flywheel side of crankcase. The exhaust tappet is closest to the PTO side of crankcase.

2. Put a rubber band or tape around the tappet stems in the #2 crankcase side. This prevents the tappets from falling into the #1 side when reassembling crankcase. Refer to Figure 11-13.

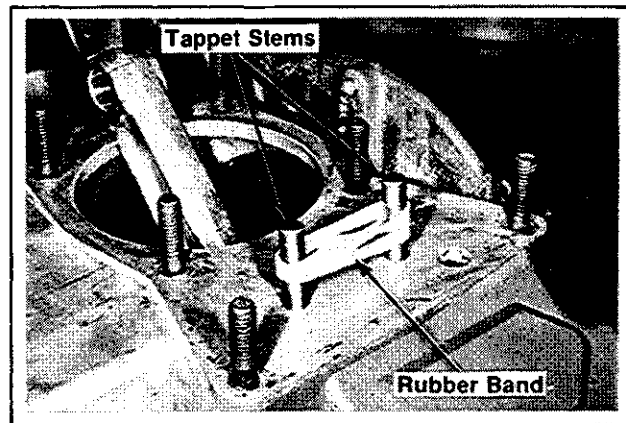

Figure 11-13. Holding Tappets (#2 Side) Using Rubber Band.

3. Place the camshaft into the #1 side of crankcase. Make sure the timing mark on crankshaft aligns with the timing mark on camgear. Refer to Figure 11-14.

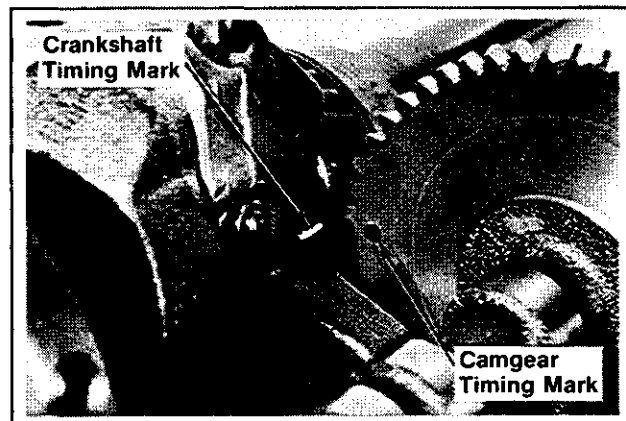

Figure 11-14. Aligning Crankshaft And Camgear Timing Marks.

4. Measure the camshaft end play with a flat feeler gauge. The recommended camshaft end play is  $.003/.013$ ". Refer to Figure 11-15. Add shim spacers, if necessary, to bring end play within range.

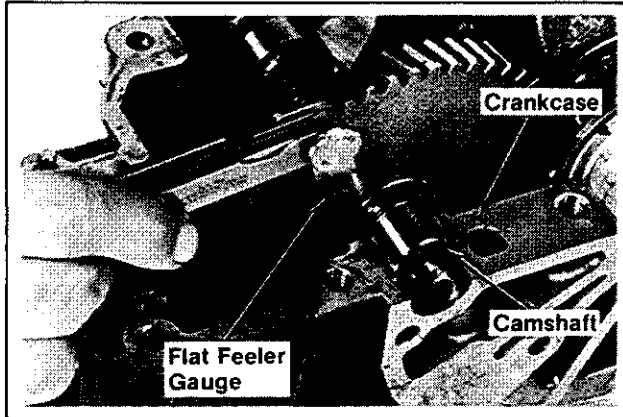

Figure 11-15. Measuring Camshaft End Play.

## INSTALL CAMSHAFT BORE PLUG AND SEAL CRANKCASE

1. Prepare the sealing surfaces of the crankcase sides and mating surfaces of crankcase and cylinder barrels as directed by the sealant manufacturer.

**CAUTION:** Do not scrape the surfaces when cleaning as this will damage the surfaces and could cause leaks. The use of a gasket removing solvent is recommended.

2. Apply a  $1/16$ " bead of sealant to the #2 crankcase side as shown in Figure 11-16. Follow the sealant manufacturer's recommendations regarding "setting." Recommended sealants are listed in the table on the following page. Silicone sealant Kohler part no. 52 597 01.

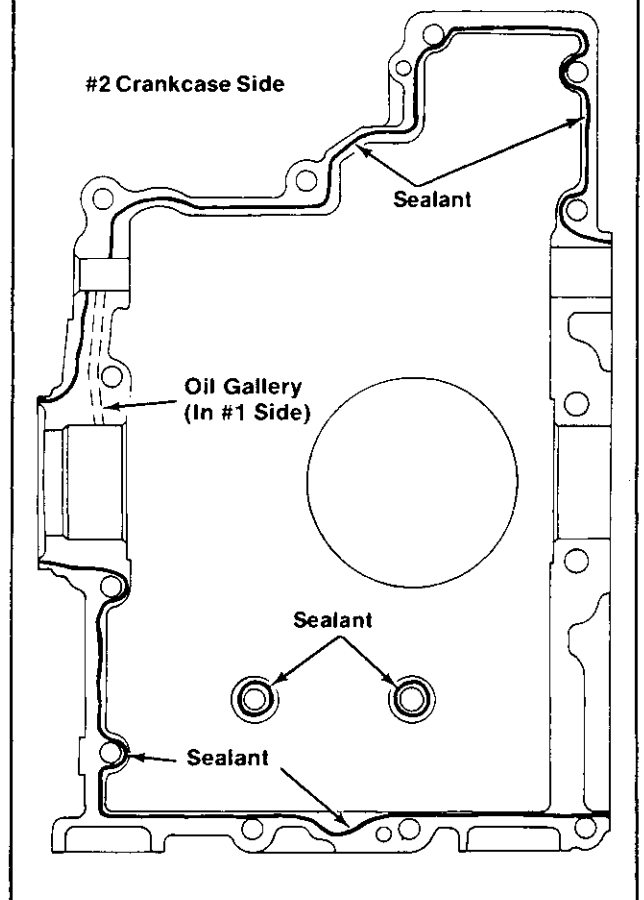
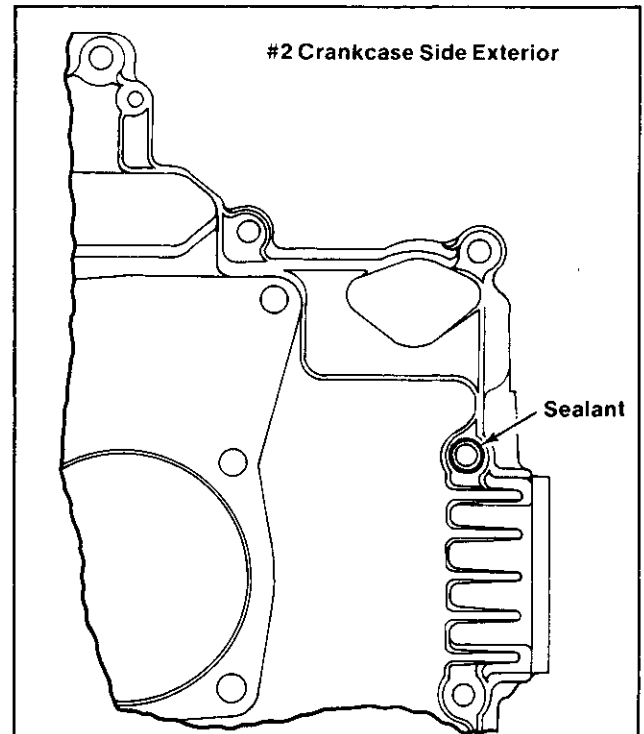

Figure 11-16. Crankcase Sealant Pattern.

## Recommended Sealants

These commercially available sealants are recommended for use on MAGNUM engines.

VENDOR	PRODUCT	VENDOR NO. & DESCRIPTION	AVAILABILITY
Dow Corning	Silicone Rubber Sealant	732 Aluminum, Black, Bronze, Clear, White	Automotive, Hardware, and Discount Stores
GE	RTV Silicone Rubber	RTV102 - White    RTV109 - Gary RTV103 - Black    RTV154 - Gray RTV106 - Red      RTV156 - Red RTV108 - Clear    Silmate - Black	GE Silicone Products Distributors
GE	Silicone Instant Gasket	Red	Automotive, Hardware, and Discount Stores
GE	Silicone Hi Temp Instant Gasket	Red	Automotive, Hardware, and Discount Stores
Loctite	Superflex Silicone Adhesive Sealant	593 - Black 594 - White 595 - Clear	Loctite Distributors
Permatex	Silicone Form-A-Gasket	6 Blue    3 oz. Bubble pack tube 6B Blue    3 oz. Boxed tube 6C Blue    11 oz. Cartridge 6M Blue    12 oz. Tube 66B Clear    3 oz. Tube 66C Clear    11 oz. Tube	Automotive Hardware, and Discount stores

**CAUTION:** Using an outdated sealant can result in seal leakage. All of the above sealants have a one to two year storage life.

3. Lubricate the o-ring of camshaft bore plug with engine oil. Insert the plug into the camshaft bore in flywheel end of #1 crankcase side.

When reinstalling a used plug, make sure the marks scribed on the crankcase and plug during disassembly are aligned. Refer to Figure 11-17.

4. Place the #2 crankcase side on the #1 side. Apply thumb pressure on the plug as the sides are brought together. Maintain pressure on the plug as the crankcase fasteners are installed and tightened. This ensures the plug shoulder is bottomed tightly against the crankcase. Refer to Figure 11-18.

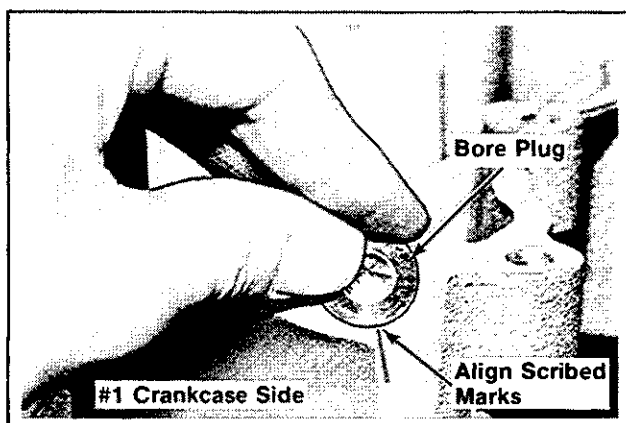

Figure 11-17. Installing Camshaft Bore Plug.

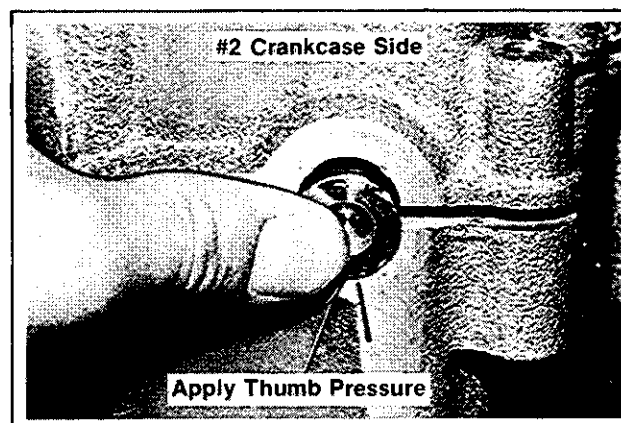
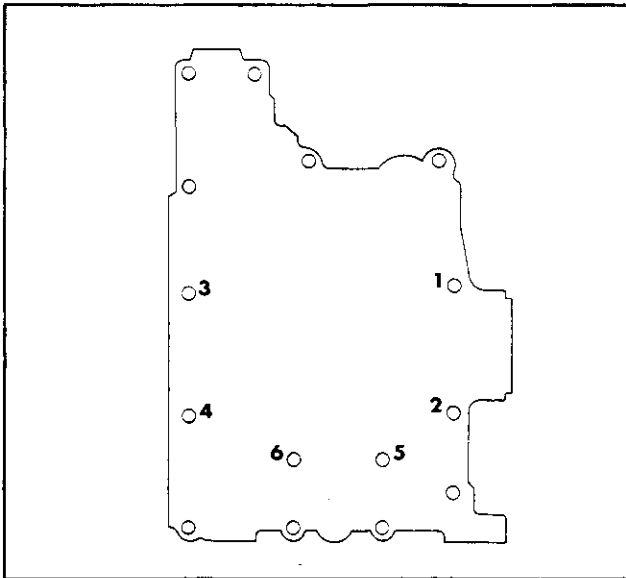

Figure 11-18. Installing #2 Crankcase Side.

5. Install the hex flange screws, plain washers, and hex nuts.
6. Torque fasteners #1 through #6 in the sequence shown to a preliminary value of **100 in. lb.** Torque the remaining fasteners to **100 in. lb.** in the most expedient sequence. Refer to Figure 11-19.



**Figure 11-19. Crankcase Fastener Torque Sequence.**

7. Torque fasteners #1 through #4 to **260 in. lb.** Torque fasteners #5 and #6 to **200 in. lb.** Torque the remaining fasteners to **200 in. lb.** in the most expedient sequence. Refer to Figure 11-19.
8. Locate a center punch in the previous stake marks surrounding the camshaft bore plug. Restake the plug securely in place. Refer to Figure 11-20.

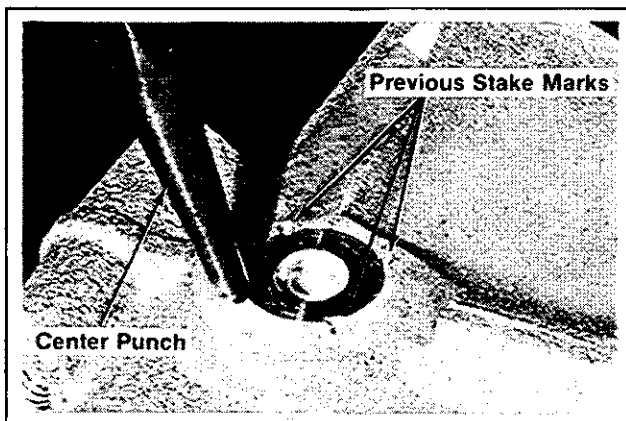
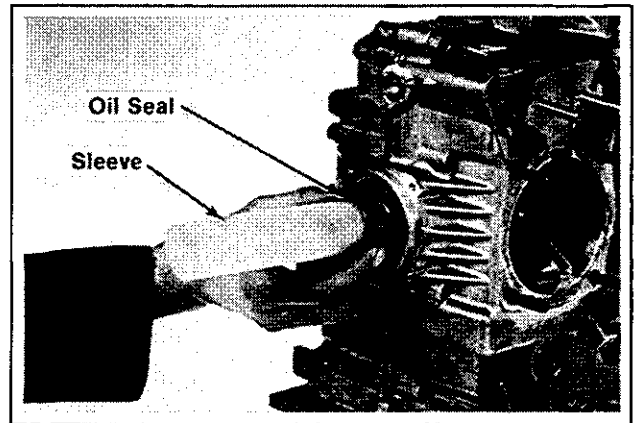

**Figure 11-20. Restaking Camshaft Bore Plug.**

9. Remove the rubber band or tape from tappets in #2 crankcase side.

### INSTALL OIL SEAL

1. Slide the appropriate seal sleeve (refer to Section 2, Special Tools) over flywheel end of crankshaft. Generously lubricate lips of oil seal with light grease. Slide oil seal over sleeve. Refer to Figure 11-21.



**Figure 11-21. Installing Oil Seal Using Sleeve.**

2. Using the handle (Tool No. NU-11795) and appropriate seal driver, install the oil seal. (depth:  $1/32'' + 3/64''$ ;  $-1/64''$ ). Refer to Figure 11-22.

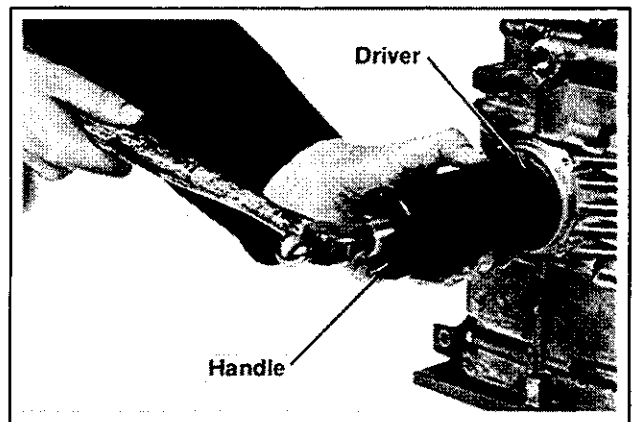

**Figure 11-22. Installing Oil Seal Using Driver.**

### INSTALL OIL PICKUP SCREEN, OIL PRESSURE RELIEF VALVE, AND OIL PAN

1. Install the oil pickup screen and self-tapping screws to oil pan. Refer to Figure 11-23.

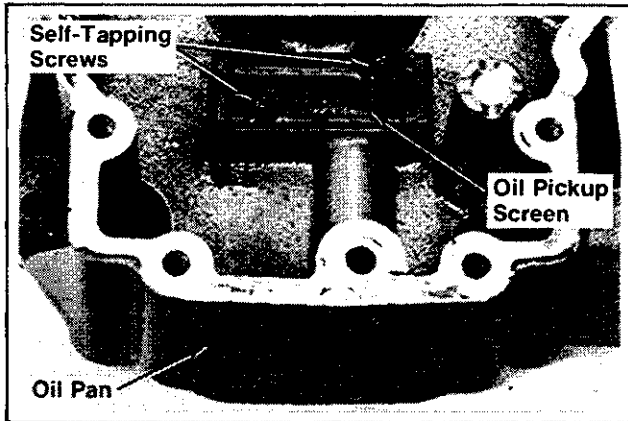

Figure 11-23. Installing Oil Pickup Screen.

2. Install the oil pressure relief valve sleeve, steel ball, and spring. Refer to Figure 11-24.

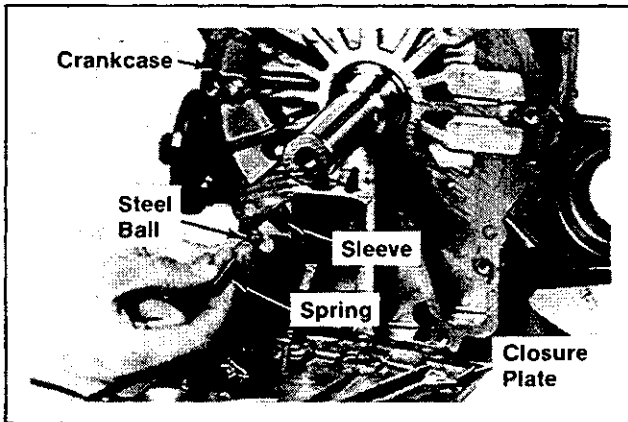

Figure 11-24. Installing Oil Pressure Relief Valve.

3. Make sure the mating surfaces of crankcase and oil pan are cleaned and prepared as directed by the sealant manufacturer. Refer to "INSTALL CAMSHAFT BORE PLUG AND SEAL CRANKCASE" found previously in this section for information on sealants.
4. Apply a 1/16" bead of sealant to the **oil pan** as shown in Figure 11-25. Follow the sealant manufacturer's recommendations regarding setting.

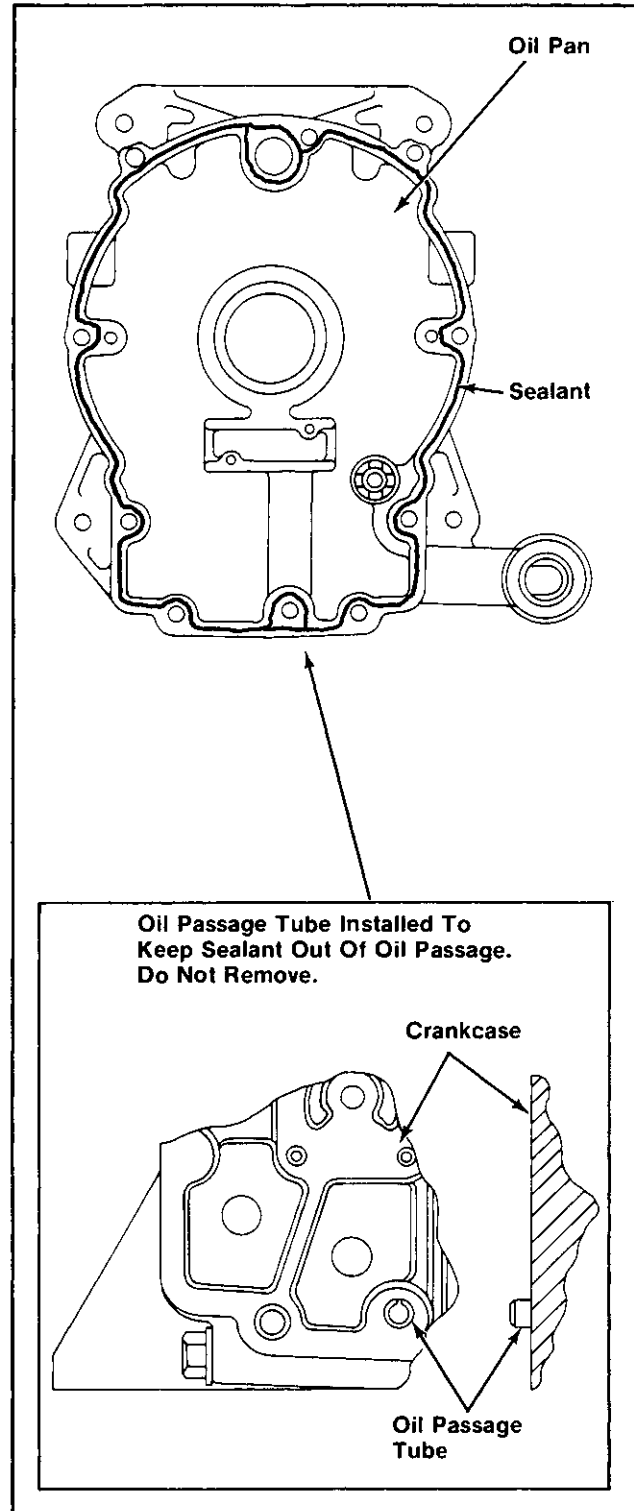

Figure 11-25. Oil Pan Sealant Pattern.

5. Install the oil pan and hex. flange screws to crankcase. Torque screws to **150 in. lb.** in the sequence shown in Figure 11-26.

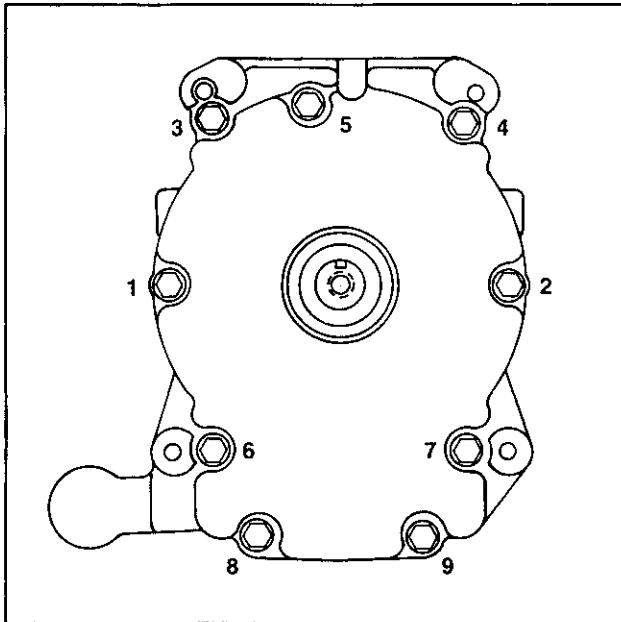

Figure 11-26. Oil Pan Fastener Torque Sequence.

### INSTALL OIL SEAL

1. Slide the appropriate seal sleeve over the PTO end of crankshaft. Generously lubricate the lips of oil seal with light grease. Slide the oil seal over sleeve. Refer to Figure 11-21.
2. Using the appropriate oil seal driver (Tool No. KO-1019), install the oil seal into the oil pan. Refer to Figure 11-27.

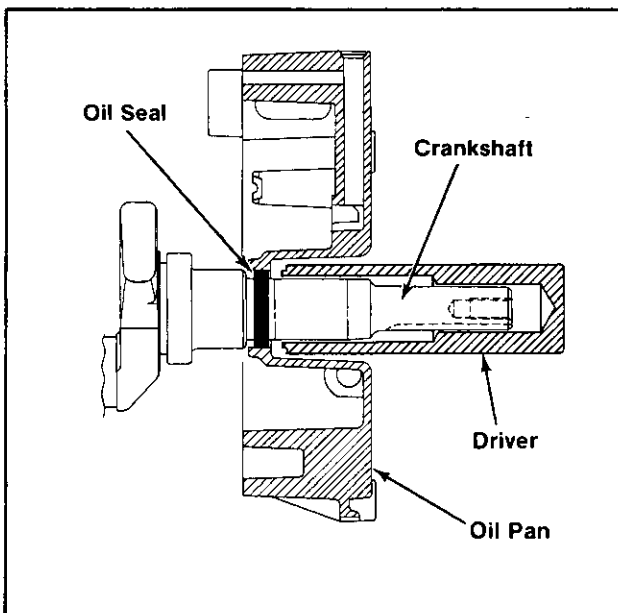

Figure 11-27. Installing Oil Seal Using Driver.

### INSTALL OIL FILTER ADAPTER

1. Install the gasket, oil filter adapter, and hex socket head screws. Make sure the arrow on filter adapter is pointing to carburetor side of crankcase. Refer to Figure 11-28.

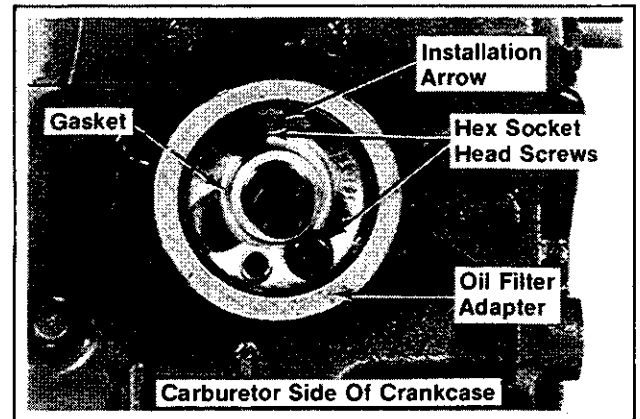

Figure 11-28. Installing Oil Filter Adapter.

2. Torque the hex socket head screws to 125 in. lb.

NOTE: Refer to the "Lubrication System" Section for installation torques of remote oil filter and oil filter bypass components.

### INSTALL PISTON RINGS

NOTE: For detailed piston inspection procedures and piston ring installation procedures, refer to the "Inspection And Repair/Reconditioning" Section.

### INSTALL PISTONS IN CYLINDER BARRELS

CAUTION: Proper orientation of the pistons within cylinder barrels is extremely important. Improper orientation may cause extensive wear or damage.

1. Stagger the piston rings in grooves until the end gaps are 120° apart.
2. Lubricate the pistons and rings with engine oil. Install piston ring compressor around pistons. Refer to Figure 11-29.

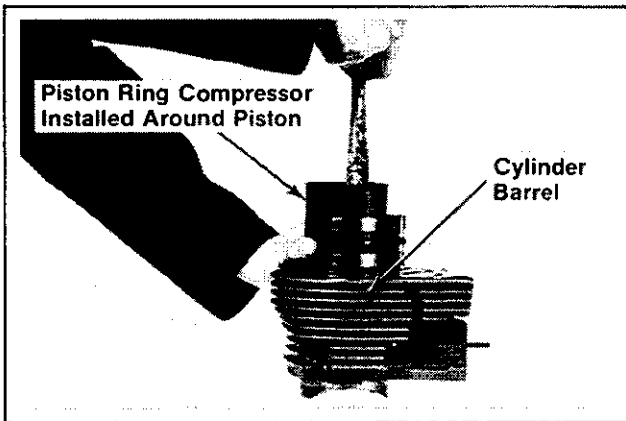

Figure 11-29. Installing Pistons.

3. Orient the "Fly" mark on pistons so it points towards flywheel (intake port) side of cylinder barrels. Refer to Figure 11-30.

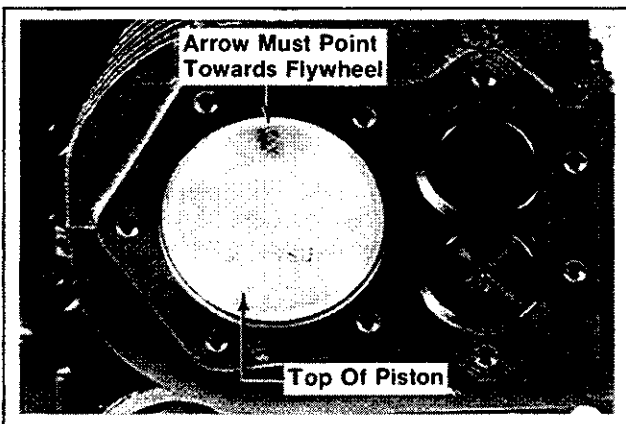

Figure 11-30. Piston Installation Direction Identifier.

Gently push the pistons into cylinder bores from cylinder head side—do not pound on piston. Refer to Figure 11-29.

Make sure that used pistons are reinstalled into the proper cylinder barrels as marked during disassembly.

4. Continue pushing the piston into bore until the piston pin bore is completely exposed on the crankcase side of cylinder barrel. Make sure the oil control ring is not exposed.

NOTE: Engine should be in a vertical position to complete assembly procedures.

## INSTALL CYLINDER BARRELS

1. Make sure the mating surfaces of crankcase and cylinder barrels are cleaned and prepared as directed by the sealant manufacturer. Refer to "INSTALL CAMSHAFT BORE PLUG AND SEAL CRANKCASE" found previously in this section for information on sealants.
2. Apply a 1/16" bead of sealant to the **crankcase** as shown in Figure 11-31. Follow the sealant manufacturer's recommendations regarding setting.

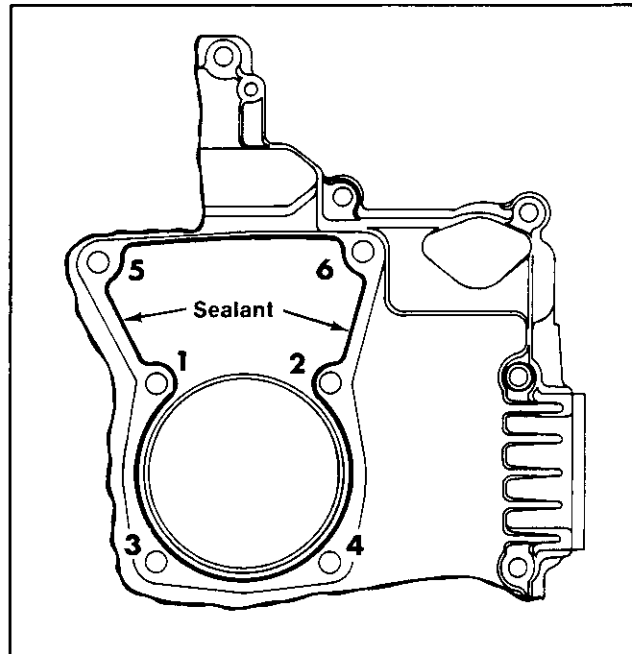

Figure 11-31. Cylinder Barrel Sealant Pattern/Cylinder Barrel Fastener Torque Sequence.

3. Install one (1) new piston pin retainer in one side of each piston pin bore.
4. Install the pistons (inside cylinder barrels), piston pins, and new piston pin retainers to connecting rods. Refer to Figure 11-32.

**CAUTION:** To prevent damage to the connecting rods when reinstalling the cylinder barrels, make sure the barrels and connecting rods are supported at all times. Do not allow the connecting rods to strike the edges of crankcase.

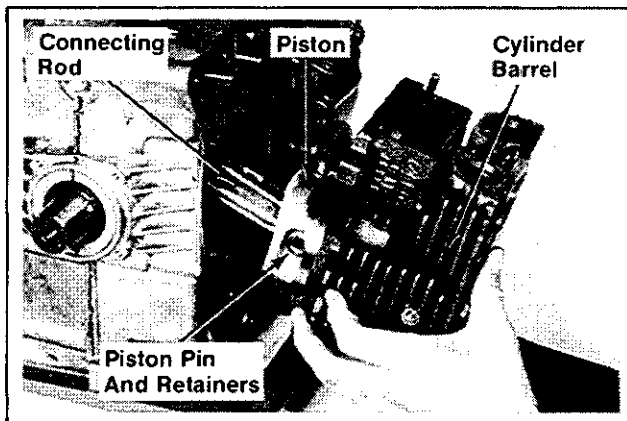

Figure 11-32. Installing Pistons/Cylinder Barrels To Connecting Rods.

5. Slide the cylinder barrels over pistons and crankcase studs. (Note #1 & #2 markings)
6. Install the plain washers and hex nuts. Torque hex nuts #1 and #2 to **100 in. lb.** Torque the remaining hex nuts to **100 in. lb.** in the most expedient sequence. Refer to Figure 11-31.
7. Torque all hex nuts to **200 in. lb.** in the sequence shown.

## MEASURE VALVE-TO-TAPPET CLEARANCE

### IMPORTANT:

The piston must be at top dead center (TDC) of the compression stroke to measure valve-to-tappet clearance. By rotating the crankshaft and observing the tappets for movement, it can be determined if a cylinder is at TDC.

If, for example, the crankshaft is rotated and movement is observed in the #2 side valve box—the opposite cylinder (#1 side) will be at TDC and valve-to-tappet clearance can be measured.

Rotating the flywheel one complete revolution (360°) will then cause movement in the #1 side valve box. The #2 side cylinder will be at TDC, enabling measurement of valve-to-tappet clearance for that side.

The valve faces and seats must be lapped-in before checking/adjusting valve-to-tappet clearance.

1. Rotate the crankshaft and look into the valve boxes. The tappets will move in only one of the boxes.

2. Install valves into valve guides for the cylinder in which **no movement** was observed. Hold valves firmly against seat and measure valve-to-tappet clearance with a flat feeler gauge. Refer to Figure 11-33.

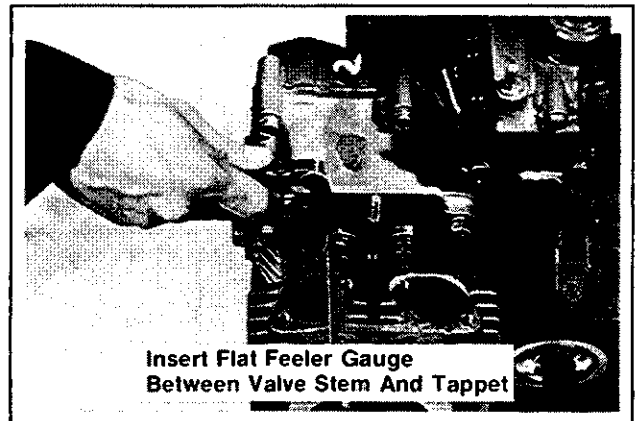

Figure 11-33. Measuring Valve-To-Tappet Clearance.

### Clearance Specifications – See Page 3.6

3. Rotate the crankshaft 360° and measure the valve-to-tappet clearance for the remaining cylinder. Refer to "Clearance Specifications."
4. If the clearance is insufficient, grind the valve stems until the correct clearance is obtained. Make sure the valve stems are ground perfectly flat and smooth.

If the clearance is excessive, replace the valves and recheck clearance.

## INSTALL VALVES

1. Install the intake valve seals to valve guides.
2. Install the valve springs (close coils towards cylinder head surface), exhaust valve rotators, lower intake valve spring retainers, and valves.
3. Compress the springs using a valve spring compressor and install keepers. Refer to Figure 11-34.



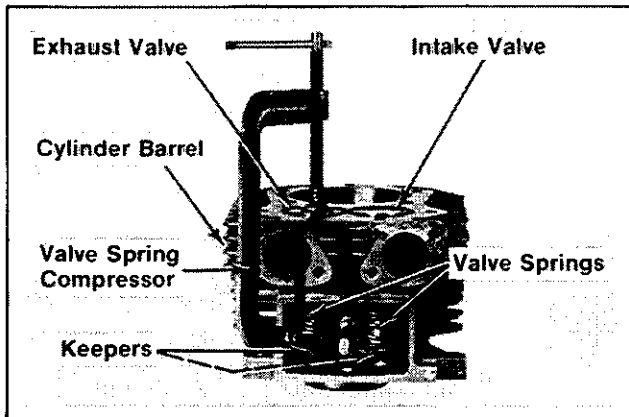

Figure 11-34. Installing Valves. Side #1 Shown.

## INSTALL CYLINDER HEADS AND SPARK PLUGS

1. Install gaskets, cylinder heads, plain washers, and hex cap screws (lubricate threads with oil). Torque hex cap screws in the sequence shown in Figure 11-35 to **15/20 ft. lb.**

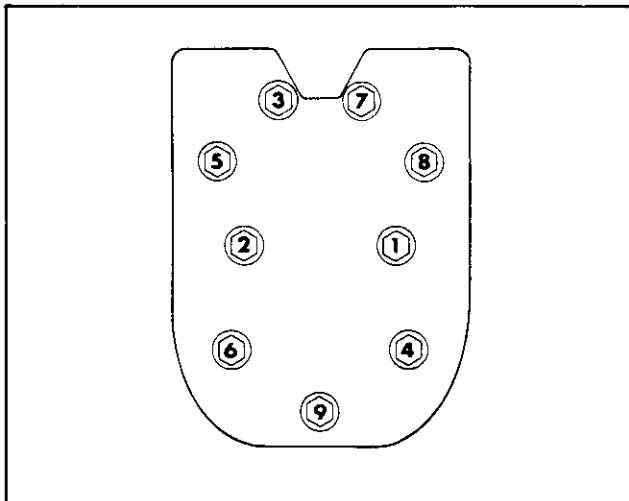

Figure 11-35. Cylinder Head Fastener Torque Sequence.

2. Install the spark plugs (**0.025" gap**); torque to **10/15 ft. lb.**

## INSTALL STATOR

1. Install the stator and self-tapping screws. Make sure the stator leads are positioned as shown in Figure 11-36.

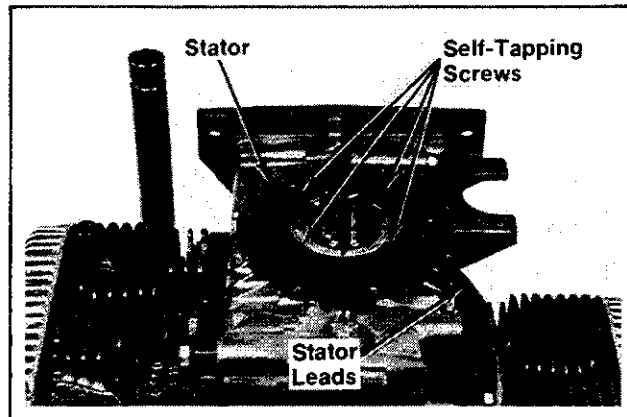

Figure 11-36. Installing Stator.

## INSTALL FAN, FLYWHEEL, AND GRASS SCREEN

**WARNING:** *Damaging Crankshaft and Flywheel Could Cause Personal Injury!*



*Using improper procedures to install the flywheel can crack or damage the crankshaft and/or flywheel. This not only causes extensive engine damage, but also is a serious threat to the safety of persons nearby, since broken fragments could be thrown from the engine. Always observe and use the following precautions and procedures when installing the flywheel.*

**CAUTION:** A. Before installing the flywheel, make sure the crankshaft taper and flywheel hub are clean, dry, and completely free of lubricants. The presence of lubricants can cause the flywheel to be overstressed and damaged when the cap screw is torqued to specification.

B. Make sure the flywheel key is installed only in the flat area of keyway, not in the rounded area. The flywheel can become cracked or damaged if the key is installed in the rounded area of keyway.

C. Always use a flywheel strap wrench to hold flywheel when tightening the flywheel fastener. Do not use any type of bar or wedge between the cooling fins or flywheel ring gear, as these parts could become cracked or damaged.

1. Install the spacers, fan, and hex flange screws. Torque screws to **115 in. lb.** Refer to Figure 11-37.

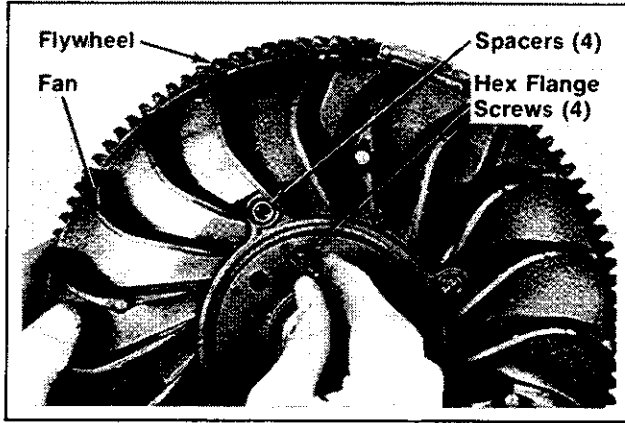

Figure 11-37. Installing Fan To Flywheel.

2. Place the flywheel on crankshaft and install plain washer, split lock washer, and hex cap screw (lubricate threads with oil). Refer to Figure 11-38.

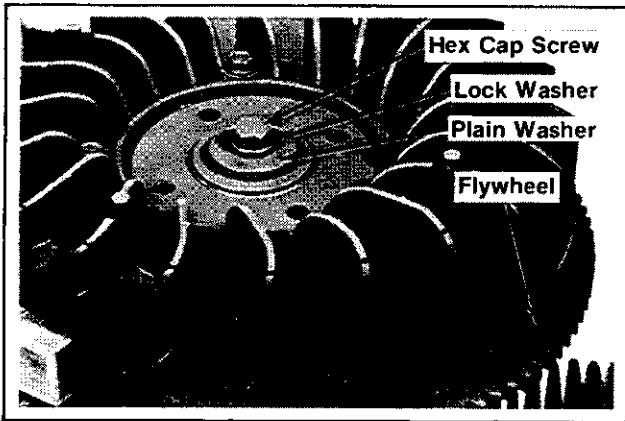

Figure 11-38. Installing Flywheel Fastener.

3. Hold the flywheel with the strap wrench and torque the hex cap screw to **40 ft. lb.**
4. Install the grass screen to fan.

### INSTALL ELECTRIC STARTER

1. Install the starter, split lock washers, and hex nuts. Refer to Figure 11-39.

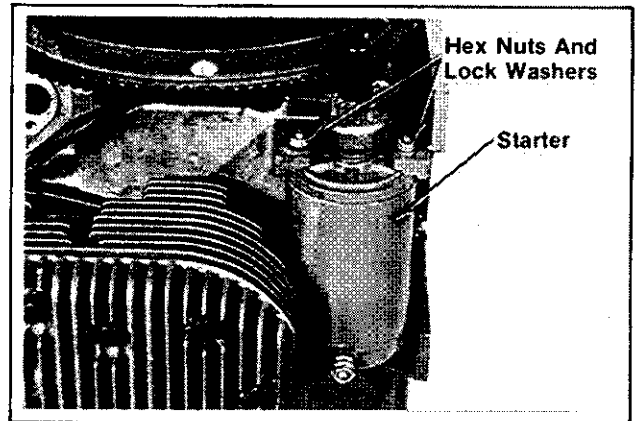

Figure 11-39. Installing Electric Starter.

### INSTALL BRACKET AND IGNITION MODULE

1. Install the bracket and hex flange screws to #1 cylinder barrel. Make sure the arrow on bracket is pointing to the carburetor side of crankcase. Refer to Figure 11-40.

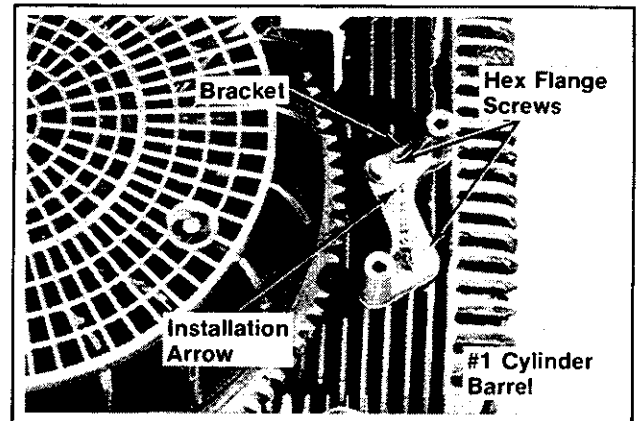

Figure 11-40. Installing Ignition Module Bracket.

2. Install the ignition module and hex flange screws to bracket. Move module as far from flywheel/magnet as possible—tighten hex cap screws slightly.
3. Align the magnet on flywheel with the module. Insert a .014" flat feeler gauge or shim stock between magnet and module. Loosen the hex flange screws so magnet pulls the module against feeler gauge. Refer to Figure 11-41. Tighten the hex flange screws securely. Remove the feeler gauge or shim stock. Due to the pull of the magnet, the magnet-to-module air gap should be within the final range of **.008"/.012"**.

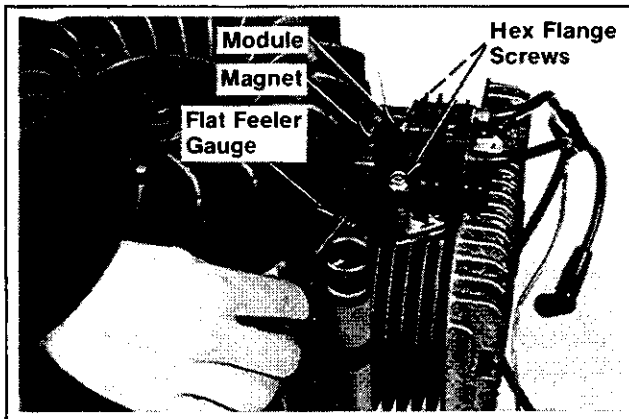

Figure 11-41. Installing Ignition Module.

4. Rotate the flywheel back and forth; check to make sure the magnet does not strike the module. Readjust gap if necessary.

## INSTALL FUEL PUMP

1. Install the gasket, fuel pump, and truss head screws. Refer to Figure 11-42.

**CAUTION:** Make sure the fuel pump lever is positioned above the camshaft. Damage to the fuel pump and subsequent severe engine damage could result if the lever is positioned below the camshaft.

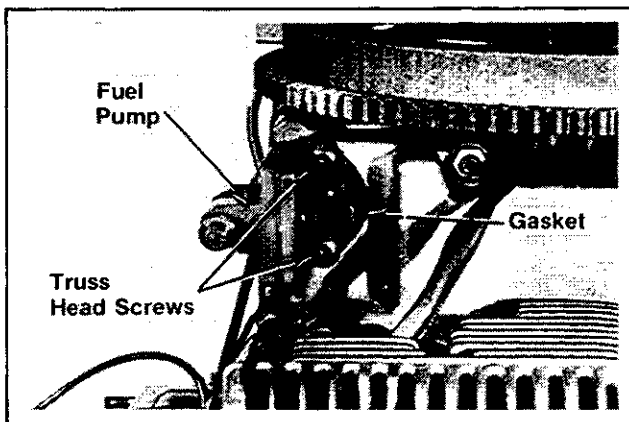

Figure 11-42. Installing Fuel Pump.

2. Torque screws to 40/45 in. lb.

## INSTALL BLOWER HOUSING, CYLINDER HEAD BAFFLES, SUPPORT BAFFLE, AND TOP BAFFLE

1. Route the stator leads to carburetor side of crankcase.

2. Install the high tension leads and kill lead into grommet. Install the grommet in slot in blower housing.
3. Install the blower housing, and self-tapping screws shown in Figure 11-43.

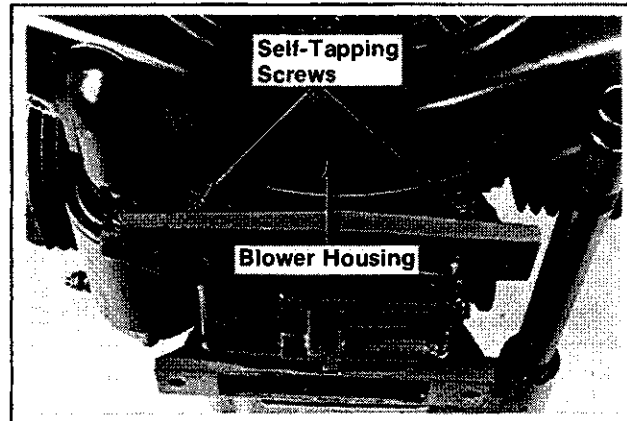

Figure 11-43. Installing Blower Housing.

4. Install the #1 side cylinder head baffle and self-tapping screws. Slide the oil fill tube support bracket onto oil fill tube and install the o-ring. Secure the bracket to blower housing with self-tapping screws. Refer to Figure 11-44.

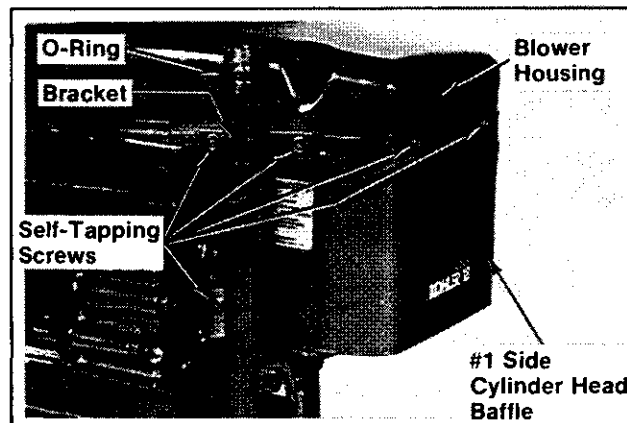

Figure 11-44. Installing #1 Side Cylinder Head Baffle.

5. Install the #2 side cylinder head baffle and self-tapping screws. Refer to Figure 11-45.

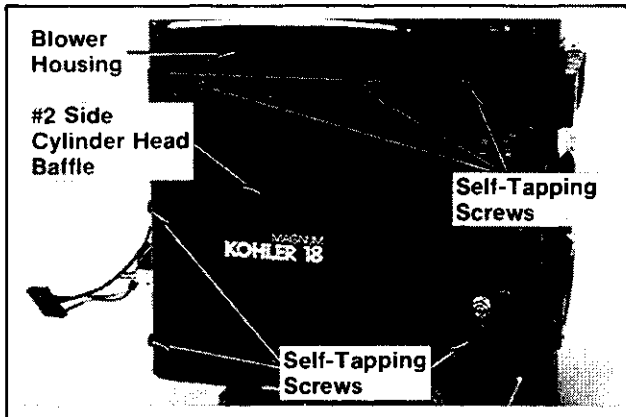

Figure 11-45. Installing #2 Side Cylinder Head Baffle.

6. Install the support baffle, top baffle, and self-tapping screws. Refer to Figure 11-46.

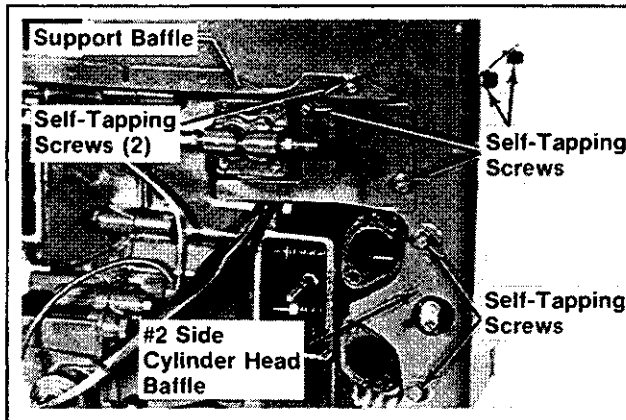

Figure 11-46. Installing Support Baffle And Top Baffle.

## INSTALL BREATHER AND VALVE COVER

### On #1 Side:

1. If removed, install the umbrella valve to breather plate. Refer to Figure 11-47.

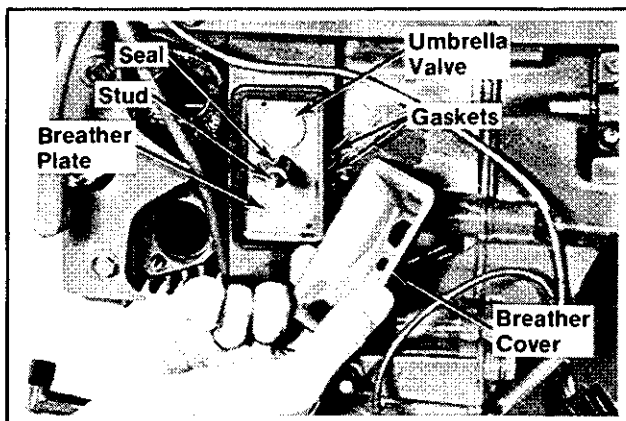

Figure 11-47. Installing Breather Components.

2. Install the gasket, breather plate, and seal. Make sure the umbrella valve is positioned above the stud (towards blower housing).
3. Install the gasket, breather cover, copper washer, and hex nut. Make sure the hole in breather cover is positioned above the hex nut (towards blower housing). Refer to Figure 11-48.

### On #2 Side:

1. Install the gasket, valve cover, copper washer, and hex nut. Refer to Figure 11-48.

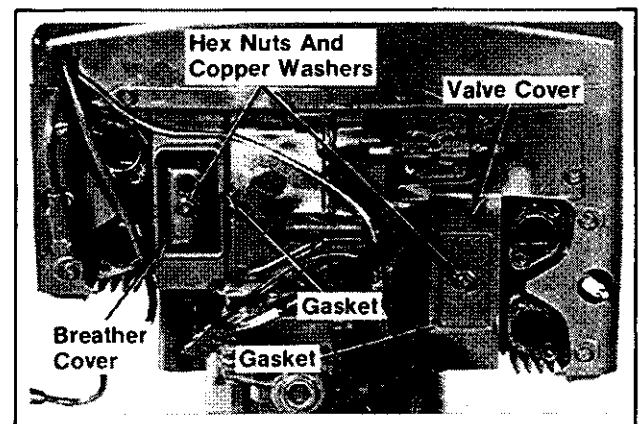

Figure 11-48. Installing Breather Cover And Valve Cover.

## INSTALL RECTIFIER-REGULATOR AND CONNECT WIRING

1. Install the rectifier-regulator and hex cap screws. Refer to Figure 11-49.

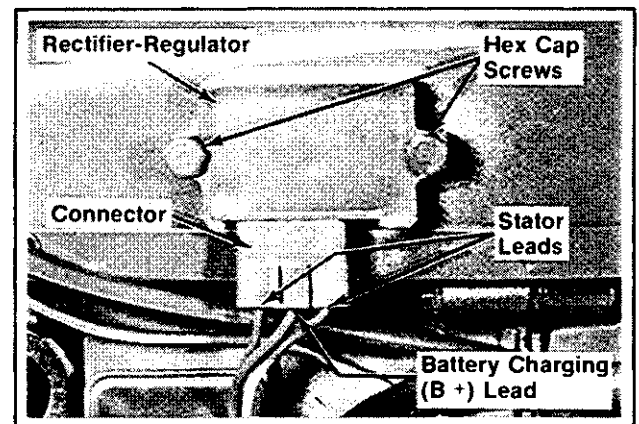

Figure 11-49. Installing Rectifier-Regulator.

2. Install the battery charging (B+) lead to center position of connector. Install the connector to rectifier-regulator.
3. Install the battery charging (B+) and kill lead to connector as necessary.

## INSTALL CARBURETOR, INTAKE MANIFOLD, AND EXTERNAL GOVERNOR COMPONENTS

1. Install the gasket, intake elbow, internal tooth lock washers, and pan head screws to carburetor. Refer to Figure 11-50.

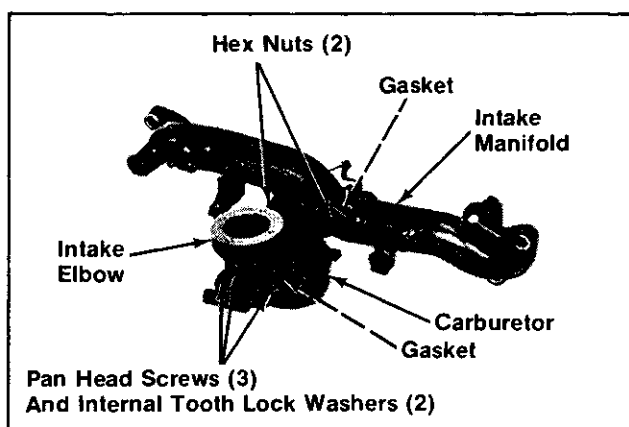

Figure 11-50. Installing Intake Elbow And Carburetor.

2. Install the gasket, carburetor with intake elbow, and hex nuts to intake manifold. Torque hex nuts to **150 in. lb.**
3. Install the gaskets, intake manifold with carburetor, plain washers, and hex socket head screws. Torque screws to **150 in. lb.** Refer to Figure 11-51.

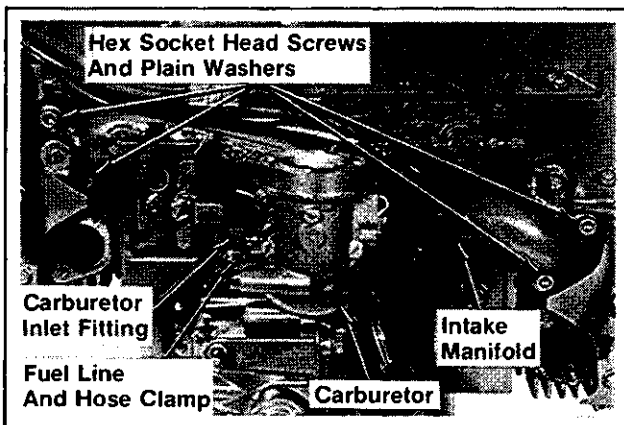

Figure 11-51. Installing Intake Manifold With Carburetor.

4. Install the fuel line and hose clamp to fuel inlet fitting on carburetor.
5. Install the plain washer and governor arm to cross shaft. Refer to Figures 11-52, 11-53, and 11-54. Do not tighten hex nut on governor arm until linkages are installed and arm is adjusted (steps 6 and 7).

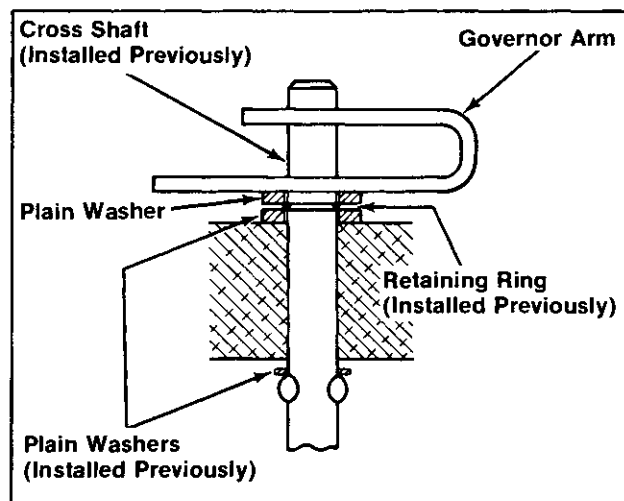

Figure 11-52. Installing Governor Arm To Cross Shaft.

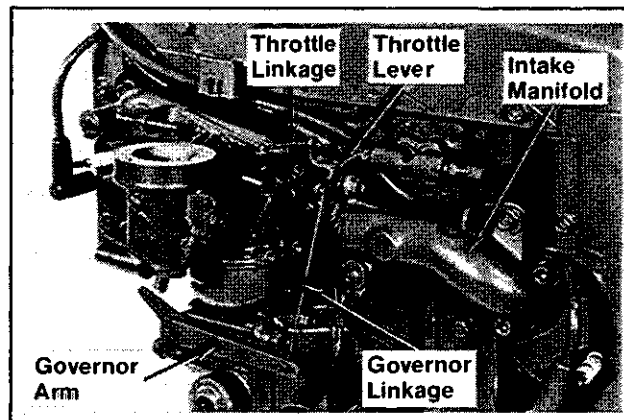

Figure 11-53. Installing External Governor Components.

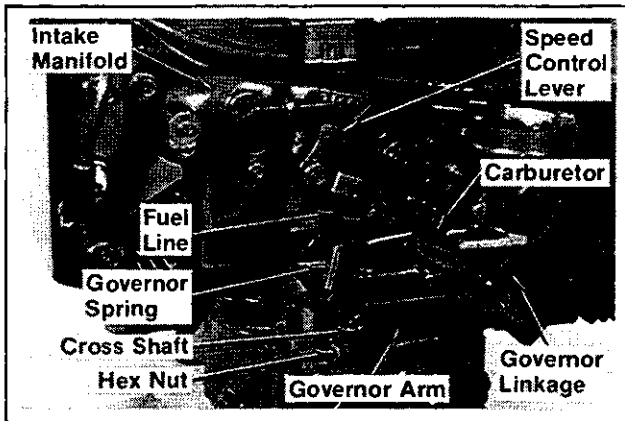

Figure 11-54. Installing External Governor Components.

6. Install the throttle linkage to throttle lever on carburetor and throttle lever on intake manifold. Install the governor linkage to throttle lever on intake manifold and governor arm.

NOTE: The linkages on some engines are secured into the bushings with small retaining clips. These clips can be eliminated by ordering and installing new bushings.

7. Governor Adjustment. Refer to Figure 11-55.

- A. Grasp the cross shaft with pliers and turn shaft clockwise as far as it will go.
- B. Pull the governor arm away from carburetor as far as it will go. Tighten the hex nut to **15 in. lb.** torque.

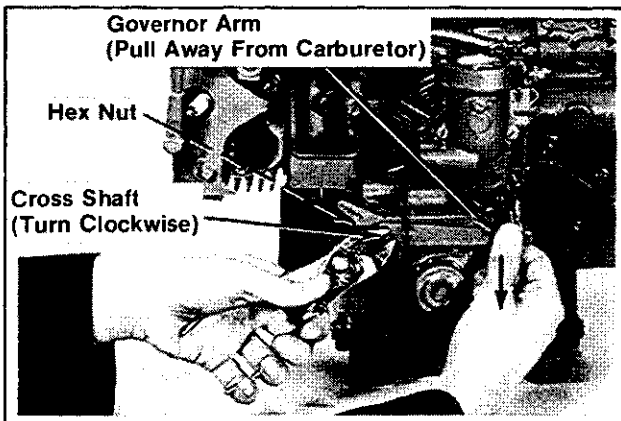

Figure 11-55. Adjusting Governor Arm/Cross Shaft.

8. Install governor spring to governor arm and speed control lever. Refer to Figure 11-54. Make sure spring is installed in the same positions as noted during disassembly, for proper operation.

## INSTALL AIR CLEANER

1. Install the gasket, air cleaner base, breather hose, and self-tapping screws. Refer to Figure 11-56.

CAUTION: Make sure the breather hose seals tightly in air cleaner base and breather cover to prevent unfiltered air from entering the engine.

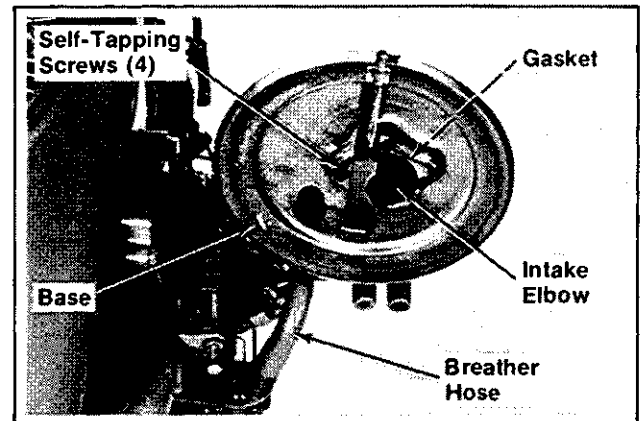

Figure 11-56. Installing Air Cleaner Base.

2. Install the paper element, optional precleaner, element cover, and element cover seal. Refer to Figure 11-57.

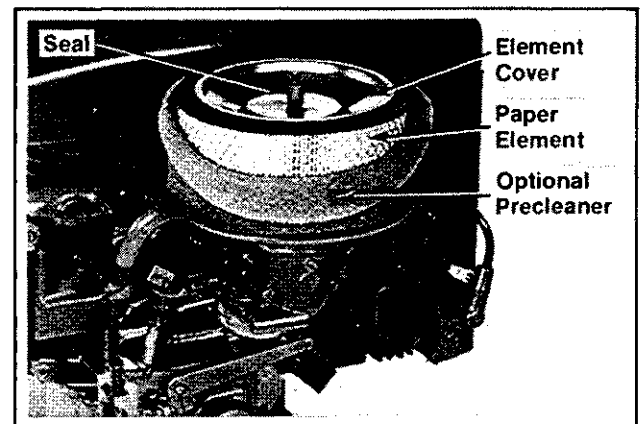

Figure 11-57. Installing Air Cleaner Element.

3. Install the air cleaner cover and wing nut. Tighten the wing nut 1/2 to 1 full turn after nut contacts cover. Do not overtighten. Refer to Figure 11-58.

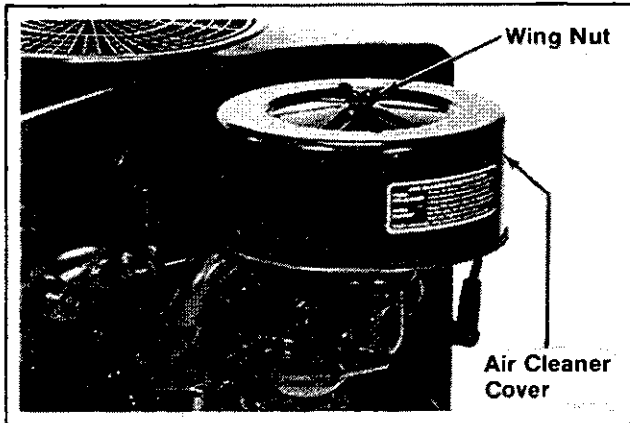

Figure 11-58. Installing Air Cleaner Cover.

## INSTALL MUFFLERS

1. Install the gaskets, mufflers, split lock washers, and hex socket screws. Torque screws to **150 in. lb.** Refer to Figure 11-59.

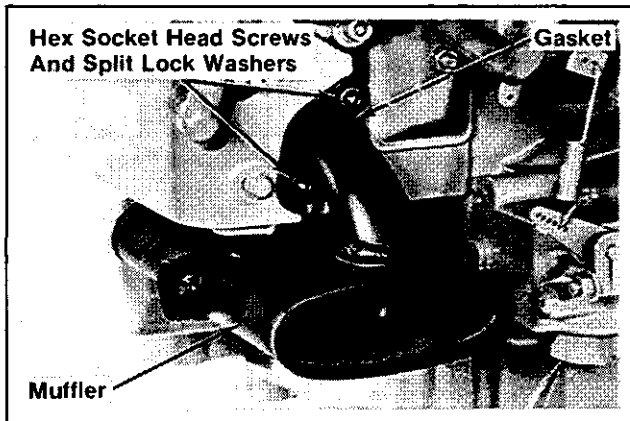

Figure 11-59. Installing Mufflers.

## INSTALL OIL FILTER

NOTE: The instructions given here are for the basic spec engine with the engine mounted oil filter. Refer to Figure 11-60. If the engine is equipped with an optional remote oil filter system, refer to the "Lubrication System" Section in this manual for installation details.

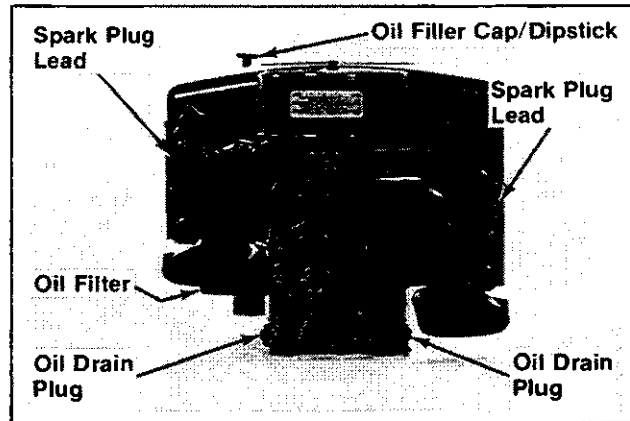

Figure 11-60. Installing Oil Filter, Oil Drain Plugs, And Spark Plug Leads.

1. Apply a thin coating of oil to the rubber seal on oil filter.
2. Turn the filter clockwise until rubber seal contacts the filter adapter, then tighten filter an additional 1/2 turn.
3. Add an additional 1/2 pint of oil for the filter capacity.

## PREPARE THE ENGINE FOR OPERATION

The engine is now completely reassembled. Before operating the engine, be sure to do the following:

- Make sure all hardware is tightened securely and oil drain plugs are installed.
- Fill the crankcase with the correct amount, weight, and type of oil. Refer to the oil recommendations and procedures in the "General Information" and "Periodic Maintenance" Sections.
- Adjust the carburetor idle fuel needle, or idle speed adjusting screw as necessary. Refer to the "Fuel System And Governor" Section.
- Make sure the maximum engine speed does not exceed 3750 R.P.M. Adjust the high speed stop as necessary. Refer to the "Fuel System And Governor" Section.

---

## TESTING THE ENGINE

It is recommended that the engine be operated on a test stand or bench prior to installation in the piece of equipment.

1. Set the engine up on a stand. Install an oil pressure gauge in the location normally used for Oil Sentry. Refer to "Lubrication system" section, figures 7-9 and 7-10. Start the engine and check to be certain that oil pressure (40 p.s.i. or more) is present. Run the engine for 5-10 minutes between idle and mid-range. Adjust the carburetor mixture settings as necessary.
2. Make sure the maximum engine speed does not exceed 3750 rpm. Adjust the throttle and choke controls and the high speed stop as necessary. Refer to the "Fuel System and Governor" section.



FOR SALES AND SERVICE INFORMATION  
IN U.S. AND CANADA, CALL  
**1-800-544-2444**

**KOHLER**<sup>®</sup>**engines**

ENGINE DIVISION, KOHLER CO., KOHLER, WISCONSIN 53044

FORM NO.:	TP-2289-A
ISSUED:	12/86
REVISED:	3/92
MAILED:	

LITHO IN U.S.A.