

KOHLER® KDW 1603 - 2204 - 2204/T

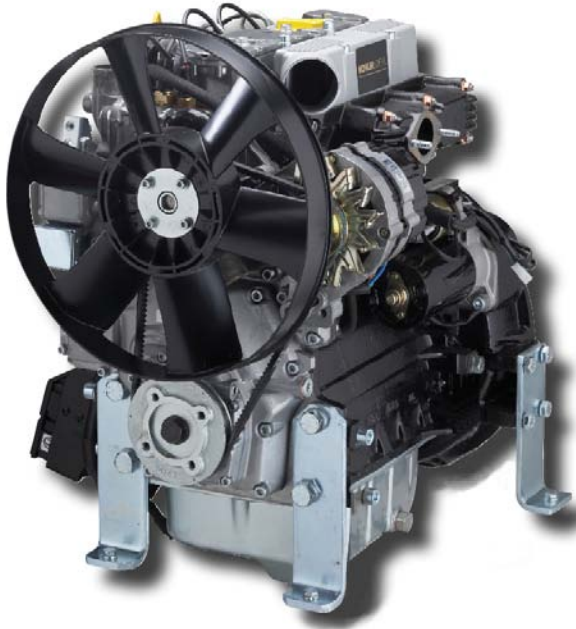



KDW 1603-2204-2204/T

PREFACE

- Every attempt has been made to present within this service manual, accurate and up to date technical information.
However, development on the **KOHLER** series is continuous.
Therefore, the information within this manual is subject to change without notice and without obligation.

- The information contained within this service manual is the sole property of **KOHLER**.
As such, no reproduction or replication in whole or part is allowed without the express written permission of **KOHLER**.

Information presented within this manual assumes the following:

- 1 - The person or people performing service work on **KOHLER** series engines is properly trained and equipped to safely and professionally perform the subject operation;
 - 2 - The person or people performing service work on **KOHLER** series engines possesses adequate hand and **KOHLER** special tools to safely and professionally perform the subject service operation;
 - 3 - The person or people performing service work on **KOHLER** series engines has read the pertinent information regarding the subject service operations and fully understands the operation at hand.
- This manual was written by the manufacturer to provide technical and operating information to authorised **KOHLER** after-sales service centres to carry out assembly, disassembly, overhauling, replacement and tuning operations.
 - As well as employing good operating techniques and observing the right timing for operations, operators must read the information very carefully and comply with it scrupulously.
 - Time spent reading this information will help to prevent health and safety risks and financial damage.
Written information is accompanied by illustrations in order to facilitate your understanding of every step of the operating phases.

**REGISTRATION OF MODIFICATIONS TO THE DOCUMENT**

Any modifications to this document must be registered by the drafting body, by completing the following table.

Drafting body	Document code	Model N°	Edition	Revision	Issue date	Review date	Endorsed
CUSE/ATLO <i>M. Primelli</i>	0053029180	51223	1°	0	02_15_2011	02_15_2011	

CHAPTER INDEX

1 - MANUFACTURER AND MOTOR IDENTIFICATION DATA 10

 The identification plate shown in the figure can be found directly on the engine 10

 Approval data 10

 Name plate for EPA rules applied on rocker-arm cap 11

 Compilation example 11

2 - GENERAL REMARKS AND SAFETY INFORMATION 12

 General remarks and safety information 12

 California emission control warranty statement 13

 Your warranty rights and obligations 13

 Safety 14

 Limited 3 year kohler diesel engine warranty 15

 General service manual notes 15

 Glossary and terminology 15

 Safety regulations 16

 General safety during operating phases 17

 Safety and environmental impact 17

3 - TECHNICAL INFORMATION 18

 Possible causes and trouble shooting 18

 Technical data 21

 Performance diagrams 22

 Overall dimensions 25

4 - MAINTENANCE - RECOMMENDED OIL TYPE - REFILLING 28

 Routine engine maintenance 28

 Ordinary maintenance 28

 Extraordinary maintenance 28

 Lubricant 29

 Prescribed lubricant 30

 Coolant 31

 Specifications fuel 31

5 - REGULATIONS FOR LIFTING THE ENGINE 32

 Regulations for lifting the engine 32

6 - DISASSEMBLY/REASSEMBLY 34

 Recommendations for disassembling and assembling 34

 Recommendations for overhauls and tuning 34

 Oil-bath air cleaner 35

 Oil-bath air cleaner components 35

 Dry air cleaner 35

 Dry air components 36

 Air filter clogging indicator 36

 Intake manifold 37

 Exhaust manifold 37

 "V" belt 37

 Cooling fan 37

 Driving pulley (2a P.T.O.) 38

 Tank 38

 Flywheel 38

 Rocker arm cover with vent into the air 39

Rocker arm cover with vent into the air	39
Rocker arm cover for engines with recirculating vent.....	39
Rocker arm assembly	40
Cylinder head.....	40
Valve removal	40
Valve spring - Check.....	41
Valve spring - check under load	41
Valve material	41
Valve guides and cylinder head.....	41
Valve guide insertion, after driving	42
Oil seal in the valves guides, (intake and exhaust).....	42
Valve seats and bore	43
Valve recess and sealing surfaces	43
Precombustion chamber.....	44
Hydraulic tappet valve control.....	44
Hydraulic diagram for feeding the tappets.....	44
Hydraulic tappet components:	44
Hydraulic tappet operation.....	45
Injection pump follower	45
Cylinders.....	46
Cylinder roughness.....	46
Piston	46
Piston availability	46
Piston weight.....	47
Piston rings - End gaps	47
Piston rings - Clearance between grooves.....	47
Piston rings - Fitting sequence	47
Piston - Refitting	48
Piston position and clearance.....	48
Cylinder head gasket	48
Cylinder head tightening for engines without hydraulic tappets	49
Cylinder head tightening steps	49
Assembling and tightening the cylinder head on engines with hydraulic tappets	49
Connecting rod	50
Connecting rod weights.....	50
Connecting rod and piston pin.....	50
Connecting rod alignment.....	51
Piston cooling sprayer	51
Connecting rod/piston assemblies	51
Center main bearings	52
Main bearing caps timing side - flywheel side.....	52
Check clearance between main bearings and journals	53
Thrust bearing, oversizes	54
Crankshaft end play.....	54
Crankshaft front and rear oil seal	55
Crankshaft timing gear.....	55
Crankshaft lubrication ducts	55
Checking main journals and crank pins.....	56
Main bearing and connecting rod big bearing inside diameter (mm)	56
Crankshaft for engines with dynamic equalizer (only four-cylinder engines)	57
Dynamic balancer (on request) - Adjustment of clearance between teeth D and ring gear A	57
Front cover (before the serial number 7366305).....	58
Front cover (after the serial number 7366306).....	58
Idler gear and hub.....	58
Speed governor	59
Dimensions for injection pump delivery control yoke adjustment	59
Camshaft gear - Speed governor counter weights	60
Speed governor counter springs	60
Frame with idling speed governor spring.....	60
Summary tables of the governor equipment according to the speed variation.....	61
Spring for extra fuel supply at starting.....	61
Camshaft.....	61
Camshaft removal.....	61
Checking camshaft bushing internal diameter	62
Camshaft journals and bushings in model KDW 1603.....	62
Camshaft journals and bushings in models KDW 2204-2204/T	62

Camshaft bushing replacement.....	62
Intake, exhaust and injection cam height for engine with hydraulic tappets	63
Camshaft timing.....	64
Valve timing without considering timing marks.....	64
Valve timing check.....	64
Engines with hydraulic tappets	65
Camshaft end play.....	66
Hydraulic pump P.T.O.....	66
GR 1 and GR 2 hydraulic pump 3rd P.T.O.	66
7 - TURBOCHARGER.....	68
Turbocharger.....	68
Turbocharger components.....	68
Turbocharger Testing.....	68
Checking actuator setting - "Waste Gate" valve control rod stroke adjustment.....	69
8 - LUBRICATION SYSTEM.....	70
Oil pump.....	71
Oil pump rotor clearance	71
Oil pressure adjusting valve.....	71
Oil filter cartridge	71
Oil pressure check.....	72
Oil pressure curve for KDW 1603.....	72
Oil pressure curve for KDW 2204.....	72
Oil pressure curve for KDW 2204/T	72
9 - COOLING SYSTEM.....	74
Expansion tank and cap	75
Checking for cooling system leaks	75
Coolant circulating pump	75
Thermostat.....	75
10 - FUEL SYSTEM.....	76
Fuel filter	77
Fuel feeding pump	77
Fuel feeding pump drive rod protrusion.....	77
Electric fuel pump (24V)	78
Injection pump	78
Injection pump disassembly	78
How to reassemble injection pump components.....	79
Injection pump non-return valve	79
Injection pump control rod	79
How to remove injection pump feeding tubes.....	79
How to reassemble injection pump feeding tubes.....	80
Instrument for equalizing injection pump delivery - Part No. 7104-1460-090.....	80
Injection pump delivery equalization	80
Test data of injection pump.....	81
Injection pump P. No. 6590-249 - Plunger and barrel assembly.....	81
Checking injection pump delivery.....	81
Checking low pressure injection timing for engines with hydraulic tappets	82
Checking low pressure injection timing for engines with mechanical tappets	83
Injection timing correction by changing the pad thickness.....	83
Injector (pin type)	84
Injector setting	84

11 - ELECTRIC SYSTEM.....	86
Wiring diagram with alternator 12V 45A / 65A / 80A	86
Recommended batteries	87
Alternator type Marelli AA 125 R 14V 45A	88
Characteristic curves for alternator type Marelli AA 125 R 14V 45A	88
Characteristic voltage curve for regulator type RTT 119 AC.....	88
Alternator type Marelli AA 125 R 14V 65A	89
Characteristic curves for alternator type Marelli AA 125 R 14V 65A	89
Characteristic voltage curve for regulator type RTT 119 AC.....	89
Alternator type Iskra, AAK3139 14V 80A	90
Characteristic curves for alternator type Iskra, AAK3139 14V 80A	90
Characteristic voltage curve for regulator type AER 1528	90
Starting Motor 12V	91
Characteristic curves for starting motor type Bosch EV 12V 2.2 kW.....	91
Wiring diagram 24V with alternator 35A	92
Recommended batteries	93
Alternator type Iskra, type AAK3570 28V 35A - (for 24 V outfits)	94
Characteristic curves for alternator type AAK3570 28V 35A (for 24 V outfits)	94
Characteristic voltage curve for regulator type AER 1528	94
Starting Motor 24V	95
Characteristic curves for starting motor Iskra type AZE 4598 24V 3 kW	95
Spacer flange for starter motor.....	95
Connection diagram for preheating control unit	96
Glow plug controller relay with coolant temperature sensor	96
Pre-heating glow plug.....	96
Temperature sensor (Thermistor).....	97
Coolant high temperature lamp switch	97
Thermistor for electric thermometer	98
Thermistor for preheating water temperature - Thermal contact for water temperature indicator light	98
12 - SETTINGS	100
Idling speed setting in no-load conditions (standard).....	100
Full speed setting in no-load conditions (standard).....	100
Standard injection pump delivery setting without torque dynamometer	100
Injection pump delivery limiting and torque adjusting device	100
Fuel limiting device (fig. 208-209).....	101
Fuel limiting device adjustment (fig. 208-209).....	101
Stop setting.....	101
Application diagram for tampering system adjustment screw and torque gearing device for EPA-approved engines ..	101
13 - ENGINE STORAGE	103
Engine storage	103
Protective treatment.....	103
Preparing the engine for operation after protective treatment	103
14 - TORQUE SPECIFICATIONS AND USE OF SEALANT	104
Main torque specifications	104
Table of tightening torques for standard screws (coarse thread)	105
Table of tightening torques for standard screws (fine thread)	105
15 - SPECIAL TOOLS	106

The identification plate shown in the figure can be found directly on the engine.

It contains the following information:

- A) Manufacturer's identity
- B) Engine type
- C) Engine serial number
- D) Maximum operating speed
- E) Number of the customer version (form K)
- F) Approval data

Approval data

The approval reference directives EC are on the engine plate (F).

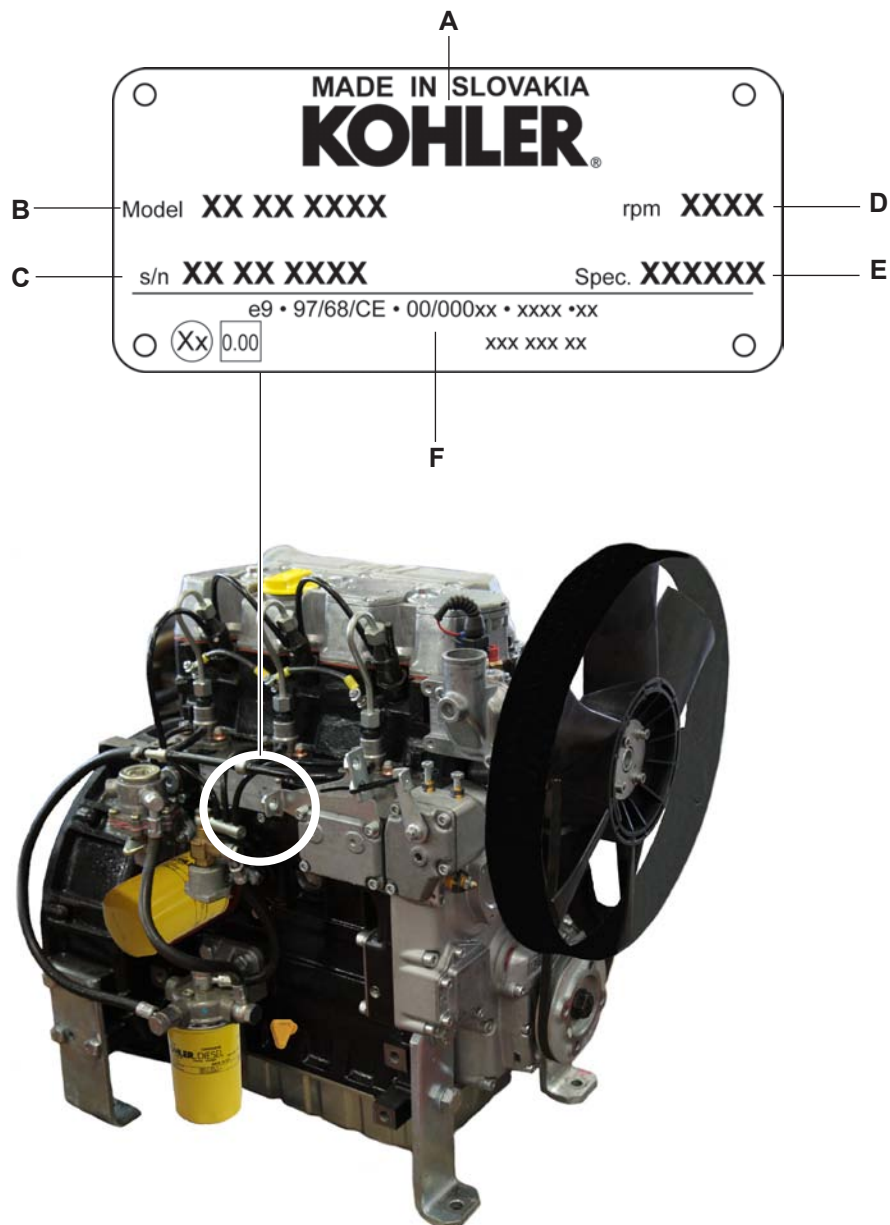

Name plate for EPA rules applied on rocker-arm cap



Compilation example

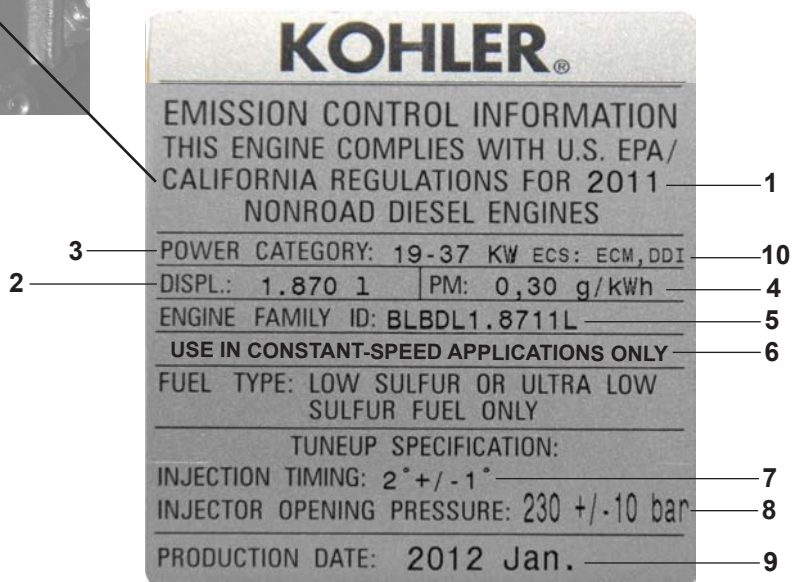

- 1) Model year.
- 2) Engine displacement.
- 3) Power category, kW.
- 4) Particulate emission limit (g/kWh).
- 5) Engine family ID.
- 6) Kind of application i.e.
- 7) Injection timing (BTDC).
- 8) Injector opening pressure (bar).
- 9) Production date (example 2012_Jan).
- 10) Emission Control System = ECS.

General remarks and safety information

To ensure safe operation please read the following statements and understand their meaning. Also refer to your equipment manufacturer's manual for other important safety information. This manual contains safety precautions which are explained below.



Danger – Attention

This indicates situations of grave danger which, if ignored, may seriously threaten the health and safety of individuals.



Caution – Warning

This indicates that it is necessary to take proper precautions to prevent any risk to the health and safety of individuals and avoid financial damage.



Important

This indicates particularly important technical information that should not be ignored.

SAFETY REGULATIONS

DANGER



Accidental Starts can cause severe injury or death.
Disable engine by disconnecting negative (-) battery cable.

Accidental Starts!

Disabling engine. Accidental starting can cause severe injury or death. Before working on the engine or equipment, disable the engine as follows: 1) Disconnect negative (-) battery cable from battery.

DANGER



Rotating Parts can cause severe injury.
Stay away while engine is in operation.

Rotating Parts!

Keep hands, feet, hair, and clothing away from all moving parts to prevent injury. Never operate the engine with covers, shrouds, or guards removed.

DANGER



Carbon Monoxide can cause severe nausea, fainting or death.
Avoid inhaling exhaust fumes, and never run the engine in a closed building or confined area.

Lethal Exhaust Gases!

Engine exhaust gases contain poisonous carbon monoxide. Carbon monoxide is odorless, colorless, and can cause death if inhaled. Avoid inhaling exhaust fumes, and never run the engine in a closed building or confined area.

DANGER



Hot Parts can cause severe burns.
Do not touch engine while operating or just after stopping.

Hot Parts!

Engine components can get extremely hot from operation. To prevent severe burns, do not touch these areas while the engine is running, or immediately after it is turned off. Never operate the engine with heat shields or guards removed.

DANGER



Fuel can cause fires and severe burns.
Do not fill the fuel tank while the engine is hot or running.

Explosive Fuel!

Fuel is flammable and its vapors can ignite. Store fuel only in approved containers, in well ventilated, unoccupied buildings. Do not fill the fuel tank while the engine is hot or running, since spilled fuel could ignite if it comes in contact with hot parts or sparks from ignition. Do not start the engine near spilled fuel. Never use fuel as a cleaning agent.

DANGER



Explosive Gas can cause fires and severe acid burns.
Charge battery only in a well ventilated area. Keep sources of ignition away.

Explosive Gas!

Batteries produce explosive hydrogen gas while being charged. To prevent a fire or explosion, charge batteries only in well ventilated areas. Keep sparks, open flames, and other sources of ignition away from the battery at all times. Keep batteries out of the reach of children. Remove all jewelry when servicing batteries. Before disconnecting the negative (-) ground cable, make sure all switches are OFF. If ON, a spark will occur at the ground cable terminal which could cause an explosion if hydrogen gas or fuel vapors are present.

! DANGER



High Pressure Fluids can puncture skin and cause severe injury or death.
Do not work on fuel system without proper training or safety equipment.

High Pressure Fluid Puncture!

Fuel system is to be serviced only by properly trained personnel wearing protective safety equipment. Fluid puncture injuries are highly toxic and hazardous. If an injury occurs, seek immediate medical attention.

! CAUTION



Electrical Shock can cause injury.
Do not touch wires while engine is running.

Electrical Shock!

Never touch electrical wires or components while the engine is running. They can be sources of electrical shock.

**California Proposition 65
WARNING**

Engine exhaust from this product contains chemicals known to the State of California to cause cancer, birth defects, or other reproductive harm.

**CALIFORNIA EMISSION CONTROL WARRANTY STATEMENT
YOUR WARRANTY RIGHTS AND OBLIGATIONS**

The California Air Resources Board and Kohler Co. are pleased to explain the **emission control system warranty** on your 2012 engine. In California, new heavy-duty off-road engines must be designed, built and equipped to meet the State's stringent anti-smog standards. Kohler Co. must warrant the emission control system on your engine for the time period listed below provided there has been no abuse, neglect or improper maintenance of your engine.

Your emission control system may include parts such as the fuel-injection system and the air induction system. Also included may be hoses, connectors and other emission related assemblies.

Where a warrantable condition exists, Kohler Co. will repair your heavy-duty off-road engine at no cost to you including diagnosis, parts and labor.

MANUFACTURER'S WARRANTY COVERAGE:

Your off-road, diesel engine emission control system is covered under warranty for a period of five (5) years or 3,000 hours, whichever occurs first, beginning on the date the engine or equipment is delivered to an ultimate purchaser for all constant speed engines with maximum power $19 \leq kW < 37$ and rated speed less than 3,000 rpm, all variable speed engines with maximum power $19 \leq kW < 37$, and all variable or constant speed engines with maximum power greater than 37 kW. Your off-road, diesel engine emission control system on variable or constant-speed engines with maximum power less than 19 kW, and for constant speed engines with maximum power $19 \leq kW < 37$ and rated speed equal to or greater than 3,000 rpm is covered under warranty for a period of two (2) years or 1,500 hours, whichever occurs first. If any emission related part on your engine is defective, the part will be repaired or replaced by Kohler Co.

OWNER'S WARRANTY RESPONSIBILITIES:

As the heavy-duty off-road engine owner, you are responsible for the performance of the **required maintenance listed in your Kohler Co. owner's manual**. Kohler Co. recommends that you retain all receipts covering maintenance on your heavy-duty off-road engine, but Kohler Co. cannot deny warranty solely for the lack of receipts or for your failure to ensure the performance of all recommended scheduled maintenance.

As the heavy-duty off-road engine owner, you should however be aware that Kohler Co. may deny you warranty coverage if your heavy-duty off-road engine or emission control related component has failed due to abuse, neglect, improper maintenance or unapproved modifications.

Your engine is designed to operate on commercial diesel fuel (No. 1 or No. 2 low sulfur or ultra low sulfur diesel fuel) only. Use of any other fuel may result in your engine no longer operating in compliance with California's emissions requirements.

You are responsible for initiating the warranty process. The Air Resources Board suggests that you present your heavy-duty off-road engine to a Kohler Co. dealer as soon as a problem exists. The warranty repairs should be completed by the dealer as expeditiously as possible.

Please review the document titled, "Kohler Co. Federal and California Emission Control Systems Limited Warranty Off-Road Diesel Engines", for complete details of your heavy-duty off-road engine warranty. If you have any questions regarding your warranty rights and responsibilities or the location of the nearest Kohler Co. authorized service location, you should contact Kohler Co. at 1-800-544-2444 or access our website at www.kohlerengines.com.

Safety

Explanation of the safety pictograms that can be found on the engine or in the Operation and Maintenance handbook

- | | | | |
|--|---|--|---|
| | Read the Operation and Maintenance handbook before performing any operation on the engine | | Use protective gloves before carrying out the operation |
| | High temperature components - Danger of scalding | | Use protective glasses before carrying out the operation |
| | Presence of rotating parts - Danger of entangling and cutting | | Use sound absorbing protections before carrying out the operation |
| | Presence of explosive fuel - Danger of fire or explosion | | Electric shock - Danger of severe scalding or death |
| | Presence of steam and pressurized coolant - Danger of scalding | | Fluids under high pressure - Danger of fluids penetration |
| | | | Lethal exhaust gas - Danger of poisoning or death |
| | | | |
| | | | |

Indications regarding the points on the engine where the safety pictograms are placed

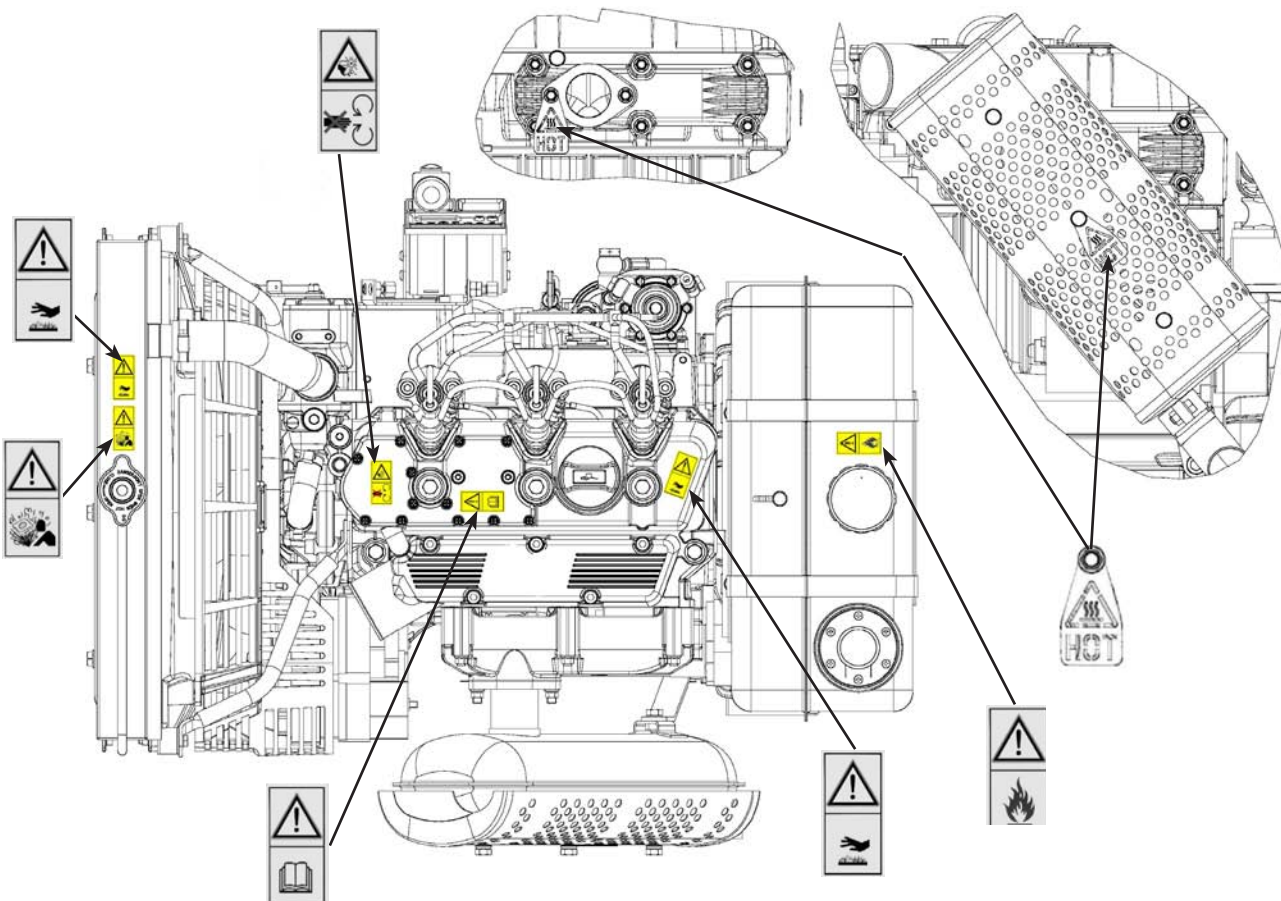

LIMITED 3 YEAR KOHLER® DIESEL ENGINE WARRANTY

Kohler Co. warrants to the original retail consumer that each new KOHLER Diesel engine sold by Kohler Co. will be free from manufacturing defects in materials or workmanship in normal service for a period of three (3) years or 2000 hours whichever occurs first from the date of purchase, provided it is operated and maintained in accordance with Kohler Co.'s instructions and manuals. If no hour meter is installed as original equipment then 8 hours of use per day and 5 days per week will be used to calculate hours used.

Our obligation under this warranty is expressly limited, at our option, to the replacement or repair at Kohler Co., Kohler, Wisconsin 53044, or at a service facility designated by us of such parts as inspection shall disclose to have been defective.

This warranty does not apply to defects caused by unreasonable use, including faulty repairs by others and failure to provide reasonable and necessary maintenance.

The following items are not covered by this warranty:

Engine accessories such as fuel tanks, clutches, transmissions, power-drive assemblies and batteries, unless supplied or installed by Kohler Co. These are subject to the warranties, if any, of their manufacturers.

KOHLER CO. AND/OR THE SELLER SHALL NOT BE LIABLE FOR SPECIAL, INDIRECT, INCIDENTAL OR CONSEQUENTIAL DAMAGES OF ANY KIND, including but not limited to labor costs or transportation charges in connection with the repair or replacement of defective parts.

IMPLIED OR STATUTORY WARRANTIES, INCLUDING WARRANTIES OF MERCHANTABILITY OR FITNESS FOR A PARTICULAR PURPOSE, ARE EXPRESSLY LIMITED TO THE DURATION OF THIS WRITTEN WARRANTY. We make no other express warranty, nor is any one authorized to make any on our behalf.

Some states do not allow limitations on how long an implied warranty lasts, or the exclusion or limitation of incidental or consequential damages, so the above limitation or exclusion may not apply to you.

This warranty gives you specific legal rights, and you may also have other rights, which vary from state to state.

To obtain warranty service

Purchaser must bring the engine to an authorized Kohler service facility. To locate the nearest facility, visit our website, www.kohlerengines.com, and use the locator function, consult your Yellow Pages or telephone 1-800-544-2444.

ENGINE DIVISION, KOHLER CO., KOHLER, WISCONSIN 53044

GENERAL SERVICE MANUAL NOTES

1 - Use only genuine Kohler repair parts.

Failure to use genuine Kohler parts could result in sub-standard performance and low longevity.

2 - All data presented are in metric format. That is, dimensions are presented in millimeters (mm), torque is presented in Newton-meters (Nm), weight is presented in kilograms (Kg), volume is presented in liters or cubic centimeters (cc) and pressure is presented in barometric units (bar).

GLOSSARY AND TERMINOLOGY

For clarity, here are the definitions of a number of terms used recurrently in the manual.

- **Cylinder number one:** is the piston timing belt side «viewed from the flywheel side of the engine».
- **Rotation direction:** anticlockwise «viewed from the flywheel side of the engine».

SAFETY REGULATIONS

GENERAL NOTES

- **Kohler** engines are built to provide safe and longlasting performances, but in order to obtain these results it is essential that the maintenance requirements described in the manual are observed along with the following safety recommendations.
- The engine has been built to the specifications of a machine manufacturer, and it is his responsibility to ensure that all necessary action is taken to meet the essential and legally prescribed health and safety requirements. Any use of the machine other than that described cannot be considered as complying with its intended purpose as specified by **Kohler**, which therefore declines all responsibility for accidents caused by such operations.
- The following instructions are intended for the user of the machine in order to reduce or eliminate risks, especially those concerning the operation and standard maintenance of the engine.
- The user should read these instructions carefully and get to know the operations described. By not doing so he may place at risk his own health and safety and that of anyone else in the vicinity of the machine.
- The engine may be used or mounted on a machine only by personnel suitably trained in its operation and aware of the dangers involved. This is particularly true for standard and, above all, special maintenance work. For special maintenance contact personnel trained specifically by **Kohler**. This work should be carried out in accordance with existing literature.
- **Kohler** declines all responsibility for accidents or for failure to comply with the requirements of law if changes are made to the engine's functional parameters or to the fuel flow rate adjustments and speed of rotation, if seals are removed, or if parts not described in the operating and maintenance manual are removed and reassembled by unauthorized personnel.



WARNING

- In addition to all other machine specifications, ensure that the engine is in a near horizontal position when starting. If starting manually, ensure that the necessary operations can be performed without any risk of striking against walls or dangerous objects. Rope starting (except for recoil rope starting) is not permitted even in emergencies.
- Check that the machine is stable so that there is no risk of it overturning.
- Get to know the engine speed adjustment and machine stop operations.
- Do not start the machine in closed or poorly ventilated environments. The internal combustion process generates carbon monoxide, an odourless and highly toxic gas, so spending too long a time in an environment where the engine discharges its exhaust products freely can lead to loss of consciousness and even death.
- The engine may not be used in environments containing flammable materials, explosive atmospheres or easily combustible powders, unless adequate and specific precautions have been taken and are clearly stated and certified for the machine.
- To prevent the risk of fire, keep the machine at a distance of at least one metre from buildings or other machines.

- Children and animals must be kept at a sufficient distance from the machine to prevent any danger resulting from its operation.
- Fuel is flammable, so the tank must be filled only when the engine is turned off. Dry carefully any fuel that may have spilled, remove the fuel container and any cloths soaked in fuel or oil, check that any sound-absorbing panels made of porous material are not soaked with fuel or oil, and make sure that the ground on which the machine is located has not absorbed fuel or oil.
- Before starting, remove any tools that have been used for carrying out maintenance work to the engine and/or the machine and check that any guards removed have been replaced. In cold climates it is possible to mix kerosene with the diesel fuel to make the engine easier to start. The liquids must be mixed in the tank by pouring in first the kerosene and then the diesel fuel. Consult **Kohler** technical office for mixture proportions. Petrol may not be used because of the risk of it forming flammable vapours.
- During operation the surface of the engine reaches temperatures that may be dangerous. Avoid in particular all contact with the exhaust system.
- The liquid cooling circuit is under pressure. Do not carry out any checks before the engine has cooled down, and even then open the radiator cap or the expansion tank cautiously. Wear protective clothing and glasses. If there is an electric fan, do not approach the engine while it is still hot as the fan may come on even when the engine is not running. Clean the cooling system with the engine turned off.
- While cleaning the oil bath air filter, check that the oil is disposed of in such a way as not to harm the environment. Any filtering sponges in the oil bath air filter should not be soaked with oil. The cyclone pre-filter cup must not be filled with oil.
- Since the oil must be emptied out while the engine is still hot (approx. 80°C), particular care should be taken in order to avoid burns. In any case make sure that oil does not come into contact with your skin because of the health hazards involved.
- Fuel vapours are highly toxic, so fill up only in the open air or in well ventilated environments.
- During operations which involve access to moving parts of the engine and/or removal of the rotary guards, disconnect and insulate the positive cable of the battery so as to prevent accidental short circuits and activation of the starter motor.
- Check the belt tension only when the engine is turned off.



IMPORTANT

- To start the engine follow the specific instructions provided in the engine and/or machine operating manual. Do not use auxiliary starting devices not originally installed on the machine (e.g. Startpilot systems which utilise ether etc.)
- Before carrying out any work on the engine, turn it off and allow it to cool down. Do not perform any operation while the engine is running.
- Check that the discharged oil, the oil filter and the oil contained in the oil filter are disposed of in such a way as not to harm the environment.
- Close the fuel tank filler cap carefully after each filling operation. Do not fill the tank right up to the top, but leave sufficient space to allow for any expansion of the fuel.
- Do not smoke or use naked flames while filling.

- . Take care when removing the oil filter as it may be hot.
- . The operations of checking, filling up and replacing the cooling liquid must be carried out with the engine turned off and cold. Take particular care if liquids containing nitrites are mixed with others not containing these compounds as this may give rise to the formation of nitrosamines which are a health hazard. The cooling liquid is polluting, so dispose of in a manner that does not damage the environment.
- . In order to move the engine simultaneously use the eyebolts fitted for this purpose by **Kohler**. These lifting points are however not suitable for the entire machine, so in this case use the eyebolts fitted by the manufacturer.

GENERAL SAFETY DURING OPERATING PHASES

- The procedures contained in this manual have been tested and selected by the manufacturer's technical experts, and hence are to be recognised as authorised operating methods.
- Some tools are normal workshop ones, while others are special tools designed by the Manufacturer of the engine.
- All tools must be in good working condition so that engine components are not damaged and that operations are carried out properly and safely.
- It is important to wear the personal safety devices prescribed by work safety laws and also by the standards of this manual.
- Holes must be lined up methodically and with the aid of suitable equipment. Do not use your fingers to carry out this operation to avoid the risk of amputation.
- Some phases may require the assistance of more than one operator. If so, it is important to inform and train them regarding the type of activity they will be performing in order to prevent risks to the health and safety of all persons involved.
- Do not use flammable liquids (petrol, diesel, etc.) to degrease or wash components. Use special products.
- Use the oils and greases recommended by the manufacturer. Do not mix different brands or combine oils with different characteristics.
- Discontinue use of the engine if any irregularities arise, particularly in the case of unusual vibrations.
- Do not tamper with any devices to alter the level of performance guaranteed by the manufacturer.

SAFETY AND ENVIRONMENTAL IMPACT

Every organisation has a duty to implement procedures to identify, assess and monitor the influence of its own activities (products, services, etc.) on the environment.

Procedures for identifying the extent of the impact on the environment must consider the following factors:

- Liquid waste;
- Waste management;
- Soil contamination;
- Atmospheric emissions;
- Use of raw materials and natural resources;
- Regulations and directives regarding environmental impact.

In order to minimise the impact on the environment, the manufacturer now provides a number of indications to be followed by all persons handling the engine, for any reason, during its expected lifetime.

- All packaging components must be disposed of in accordance with the laws of the country in which disposal is taking place.
- Keep the fuel and engine control systems and the exhaust pipes in efficient working order to limit environmental and noise pollution.
- When discontinuing use of the engine, select all components according to their chemical characteristics and dispose of them separately.

POSSIBLE CAUSES AND TROUBLE SHOOTING
THE ENGINE MUST BE STOPPED IMMEDIATELY WHEN:

- 1) - The engine rpms suddenly increase and decrease
- 2) - A sudden and unusual noise is heard
- 3) - The colour of the exhaust fumes suddenly darkens
- 4) - The oil pressure indicator light turns on while running.

TABLE OF LIKELY ANOMALIES AND THEIR SYMPTOMS

The following table contains the possible causes of some failures which may occur during operation. Always perform these simple checks before removing or replacing any part.

POSSIBLE CAUSE		TROUBLE										
		Engine does not start	Engine starts but stops	No acceleration	Non-uniform speed	Black smoke	White smoke	Too low oil pressure	Overheats	Inadequate performance	Excessive oil consumption	High noise level
FUEL CIRCUIT	Obstructed fuel line											
	Fuel filter clogged											
	Air or water leaks in fuel system											
	The tank cap vent hole is clogged											
	No fuel											
ELECTRIC SYSTEM	Discharged battery											
	Cable connection uncertain or incorrect											
	Faulty starting switch											
	Faulty starting motor											
	Faulty glow plugs											
	Faulty glow plug control relay											
MAINTENANCE	Burnt fuse on preheating spark plugs											
	Clogged air filter											
	Excessive idle operation											
	Incomplete run-in											
SETTINGS REPAIRS	Overloaded engine											
	Incorrect governor linkage adjustment											
	Governor spring broken or unhooked											
	Low idle speed											
	Rings worn or sticking											
	Worn cylinder											
	Worn main con rod-rocker arm bearings											
	Badly sealed intake valve											
	Damaged cylinder head gasket											
	Defective timing system											
	Bent rods											
Faulty hydraulic tappets												

POSSIBLE CAUSE		TROUBLE										
		Engine does not start	Engine starts but stops	No acceleration	Non-uniform speed	Black smoke	White smoke	Too low oil pressure	Overheats	Inadequate performance	Excessive oil consumption	High noise level
INJECTION	Damaged injector											
	Injection pump valve damaged											
	Injector not adjusted											
	Faulty fuel feeding pump											
	Hardened pump control rod											
	Broken or loose supplementary start-up spring											
	Worn or damaged pumping element											
	Incorrect tuning of injection components (delivery balancing advance)											
	Cracked or broken precombustion chamber											
LUBRICATION CIRCUIT	Oil level too high											
	Oil level low											
	Oil pressure valve blocked or dirty											
	Worn oil pump											
	Oil sump suction line clogged											
	Faulty pressure gauge or pressure switch											
	Blocked draining pipe											
	Faulty spray nozzles (Turbo engines only).											
	Blocked draining pipe											
COOLING CIRCUIT	Alternator fan belt loose or torn											
	Clogged radiator exchange surface											
	Insufficient coolant											
	Fault fan, radiator or radiator plug											
	Faulty thermostatic valve											
	Blockage inside the radiator or the coolant ducts											
	Coolant leaking from radiator, hoses, the crankcase or from the water pump											
	Faulty or worn water pump											

TECHNICAL DATA

ENGINE TYPE		KDW 1603	KDW 2204	KDW 2204/T
Cylindres	N°	3	4	4
Bore	mm	88	88	88
Stroke	mm	90.4	90.4	90.4
Displacement	Cm ³	1649	2199	2199
Compression ratio		22:1	22:1	22:1
R.P.M.		3000	3000	3000
Power KW	N 80/1269/CEE-ISO 1585-DIN 70020	30.0	38.0	49.2
	NB ISO 3046 - 1 IFN - DIN 6270	27.6	34,5	47
	NA ISO 3046 - 1 ICXN - DIN 6270	25.4	32.0	42.3
Max. torque *	Nm	113	144	190
	RPM	@ 1600	@ 2200	@ 1800
Max. torque 3rd + 4th p.t.o.	Nm	39.2	39.2	39.2
	g/KWh	@ 3000	@ 3000	@ 3000
Oil consumption **	Kg/h	0.019	0.025	0.04
Dry weight	Kg	156	192	197
Combustion air volume at 3000 r.p.m.	l./1'	2475	3300	4200
Cooling air volume at 3000 r.p.m.	m ³ /mm	96	128	180
Max. permissible driving shaft axial load in both directions	Kg	300	300	300
Max inclination	Max. 60 seconds	α	35°	35°
	Lasting up to 30 seconds	α	25°	25°
	Permanent	α	***	***
Firing Order		1-3-2	1-3-4-2	1-3-4-2

* Referred to max. N power

** At NA power

*** Depending on the application

KDW 1603

KDW 2204/T

KDW 2204

PERFORMANCE DIAGRAMS

CHARACTERISTICS POWER, TORQUE AND SPECIFIC FUEL CONSUMPTION CURVES

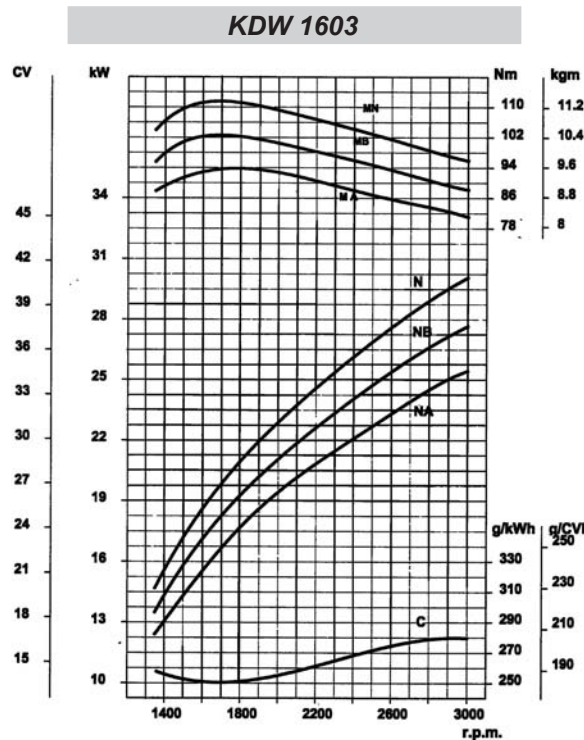

N (80/1269/CEE - ISO 1585) AUTOMOTIVE RATING: intermittent operation with variable speed and variable load.

NB (ISO 3046 - 1 IFN) RATING WITH NO OVERLOAD CAPABILITY: Continuous light duty operation with constant speed and variable load.

NA (ISO 3046 - 1 ICXN) CONTINUOUS RATING WITH OVERLOAD CAPABILITY: continuous heavy duty with constant speed and constant load.

MN Torque curve (N curve) - MB (NB curve) - MA (NA curve) - C: Specific fuel consumption curve (NB curve)

Max. power tolerance is 5%. Power decreases by approximately 1% every 100 m altitude and by 2% every 5°C above 25°C.

Engine power can be influenced by the type of coupling used with the cooling fan.

CHARACTERISTICS POWER, TORQUE AND SPECIFIC FUEL CONSUMPTION CURVES

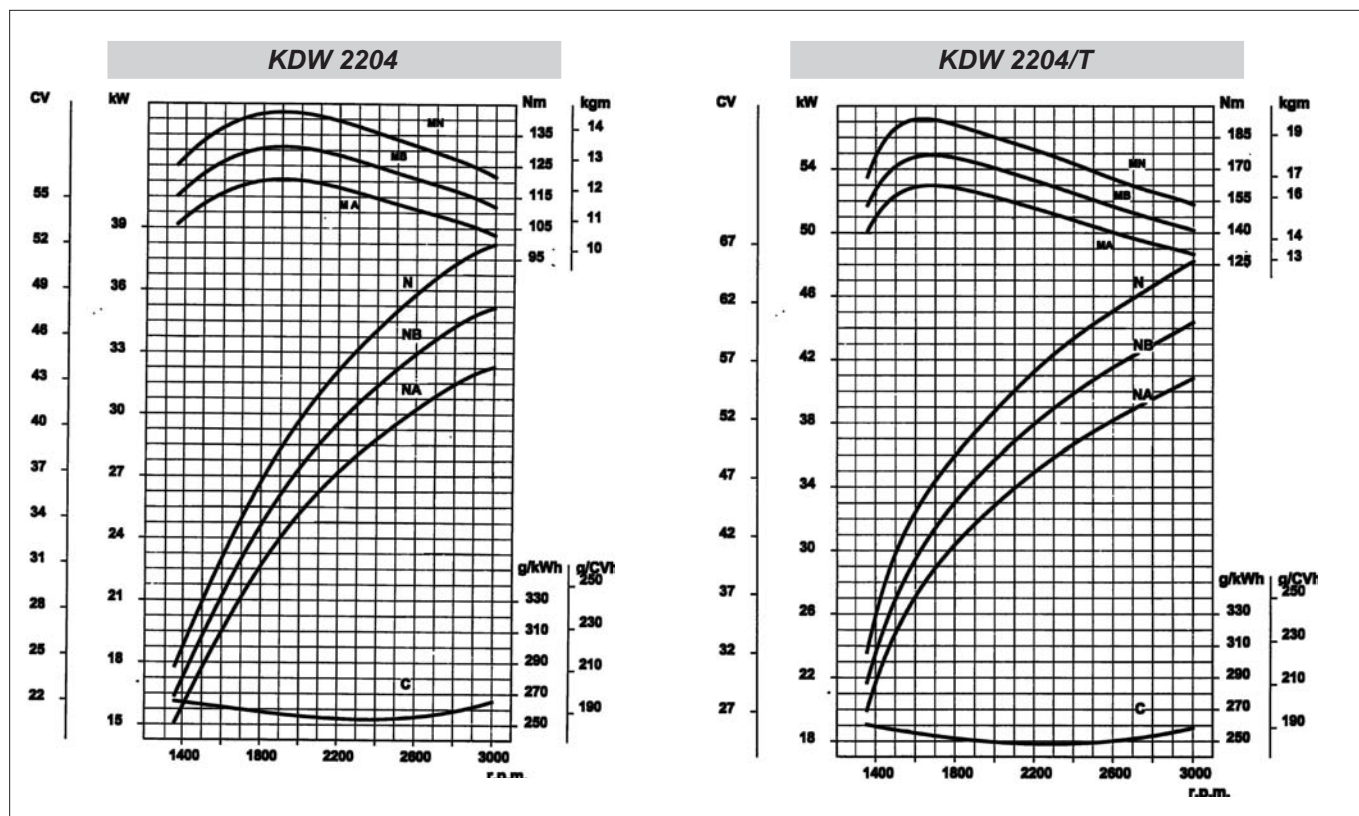

N (80/1269/CEE - ISO 1585) AUTOMOTIVE RATING: intermittent operation with variable speed and variable load.

NB (ISO 3046 - 1 IFN) RATING WITH NO OVERLOAD CAPABILITY: Continuous light duty operation with constant speed and variable load.

NA (ISO 3046 - 1 ICXN) CONTINUOUS RATING WITH OVERLOAD CAPABILITY: continuous heavy duty with constant speed and constant load.

MN Torque curve (N curve) - MB (NB curve) - MA (NA curve).

C: Specific fuel consumption curve (NB curve)

Max. power tolerance is 5%.

Power decreases by approximately 1% every 100 m altitude and by 2% every 5°C above 25°C.

Engine power can be influenced by the type of coupling used with the cooling fan.



Important

Non-approval by Kohler for any modifications releases the company from any damages incurred by the engine.

Note: Consult KOHLER for power, torque curves and specific consumptions at rates differing from those given above.

Lined area for technical information with horizontal dotted lines.

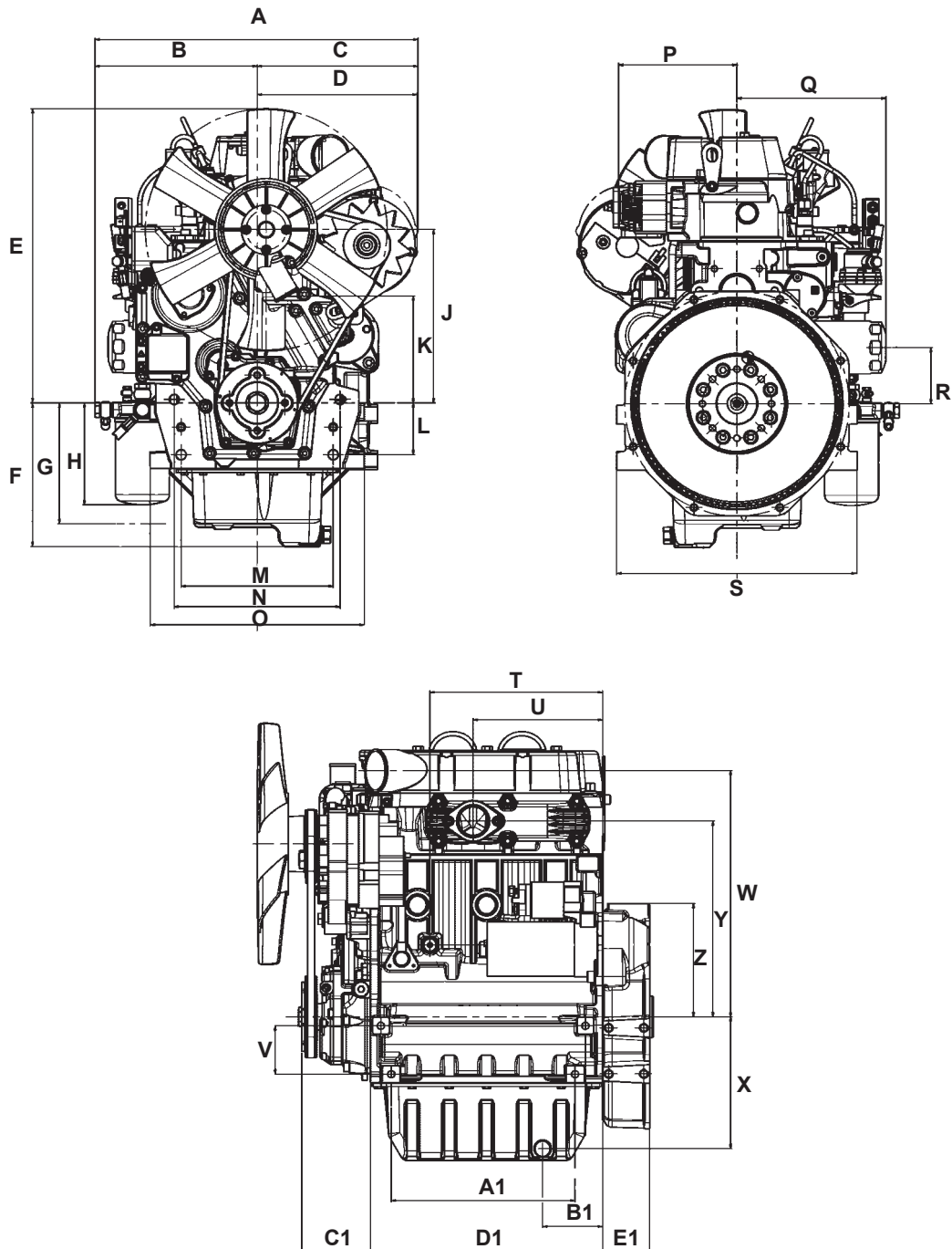
OVERALL DIMENSIONS
KDW 1603

Note : Dimensions shown in mm

DIMENSIONS mm											
A	468	F	208	L	75	Q	215.7	V	70	A1	266
B	235	G	175	M	220	R	81	W	356.4	B1	87
C	233 max	H	147.5	N	240	S	348	X	191	C1	99.6
D	231.3	J	250.2	O	310	T	250	Y	283.3	D1	336
E	425.2	K	154.2	P	171	U	187.5	Z	164	E1	68

KDW 2204

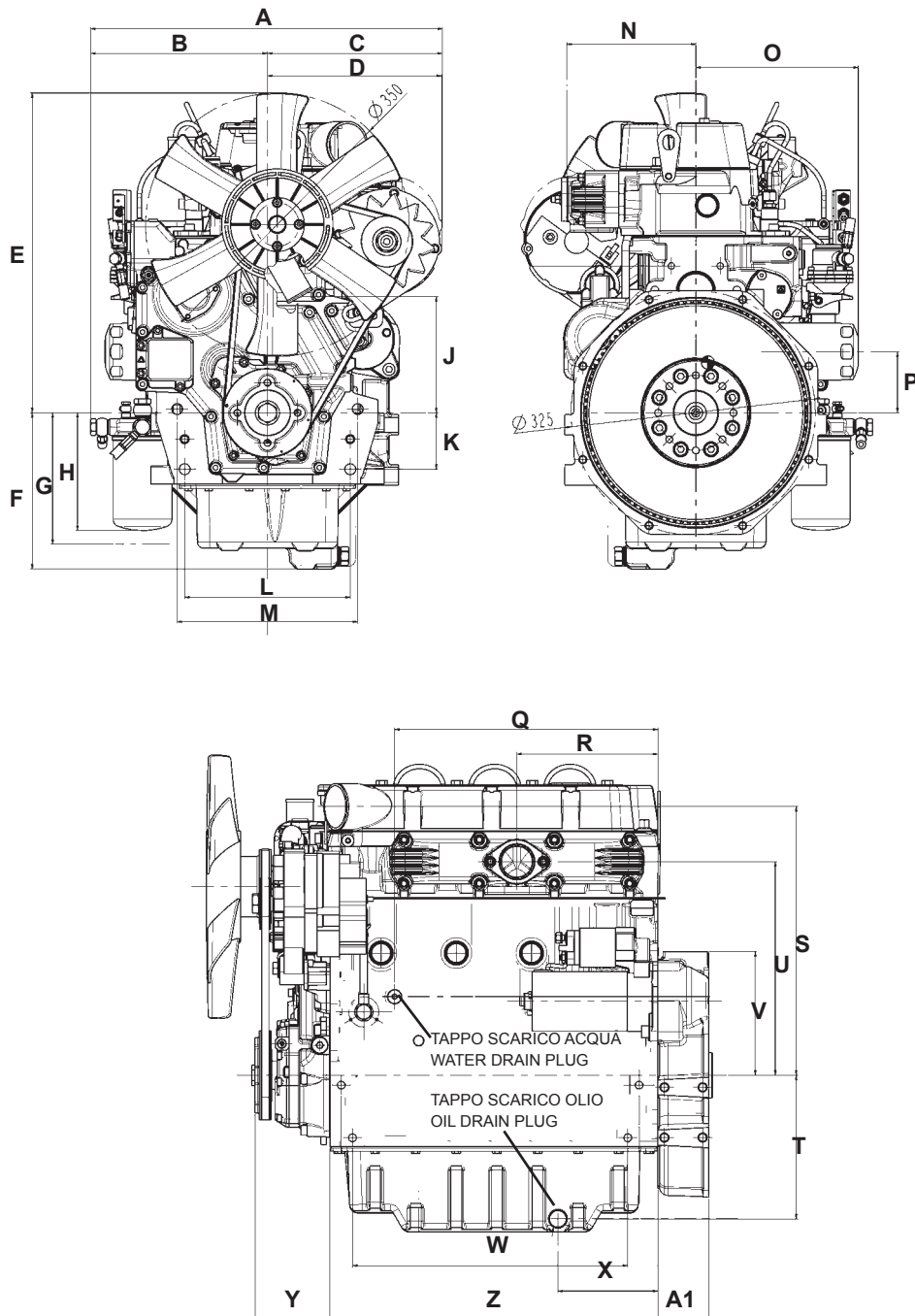

Note : Dimensions shown in mm

DIMENSIONS mm

A	468	F	208	L	220	Q	350	V	164	A1	68
B	235	G	175	M	240	R	187.5	W	366		
C	233	H	156.5	N	171	S	356.3	X	133		
D	231.3	J	154.2	O	215.7	T	191	Y	99.6		
E	425.2	K	75	P	81	U	283.3	Z	436		

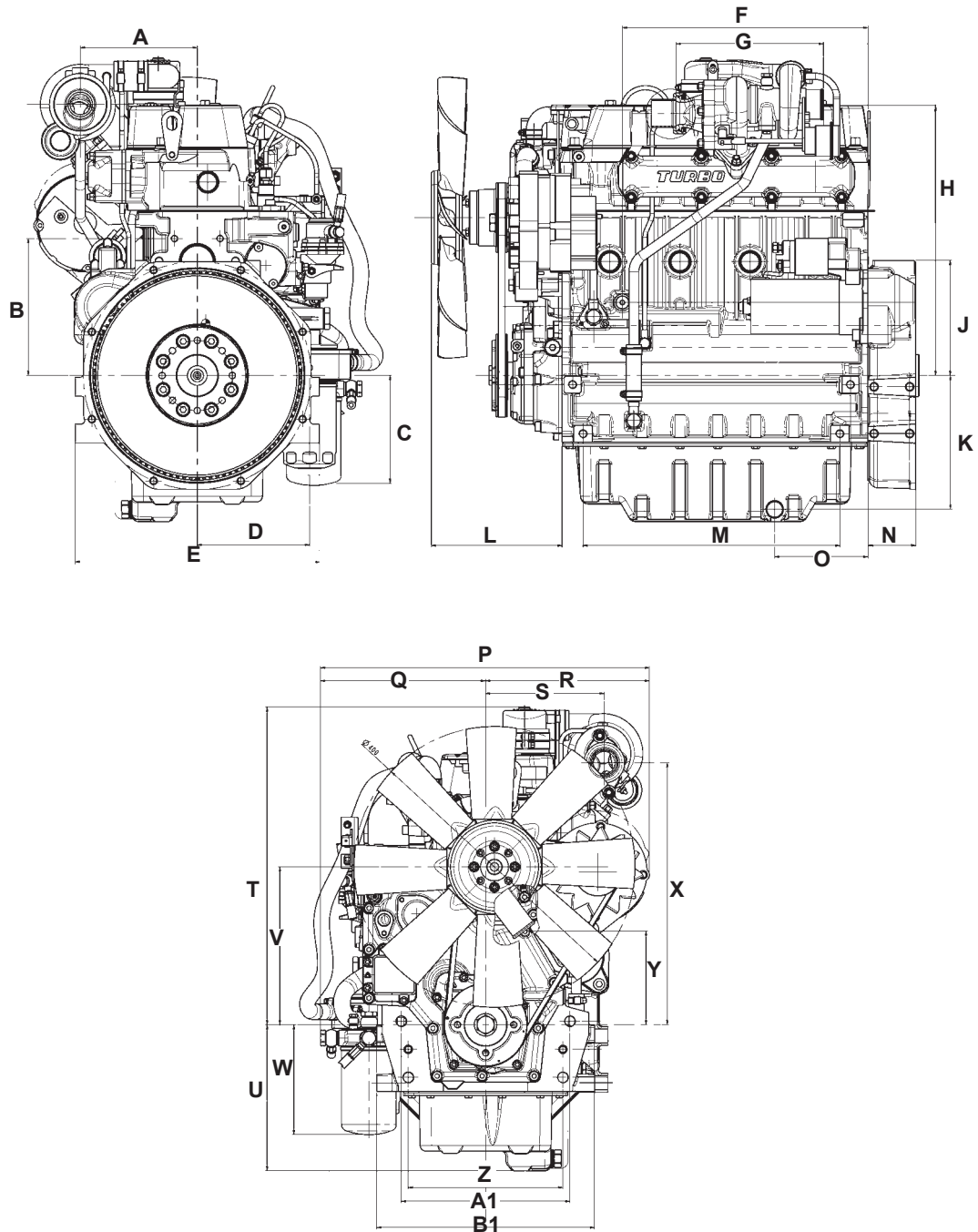
KDW 2204/T

Note : Dimensions shown in mm

DIMENSIONS mm											
A	166.7	F	350	L	186.3	Q	235	V	224.8	A1	210
B	195	G	210	M	366	R	233.1	W	156.5	B1	310
C	153.5	H	386.1	N	68	S	168.7	X	373.2		
D	160	J	164	O	133	T	452.5	Y	133.5		
E	348	K	190.5	P	468.1	U	208	Z	220		

ROUTINE ENGINE MAINTENANCE

Caution – Warning

Failure to carry out the operations described in the table may lead to technical damage to the machine and/or system.

ORDINARY MAINTENANCE

AFTER THE FIRST 50 WORKING HOURS

Engine oil replacement.

Oil filter replacement.

EXTRAORDINARY MAINTENANCE

			10	200	300	600	1200	5000	10000	
CHECK	LEVEL ENGINE LUBRICANT									
	COOLANT LEVEL									
	DRY AIR CLEANER	(***)								
	OIL BATH AIR CLEANER									
	RADIATOR EXCHANGE SURFACE									
	BELT FAN/ALTERNATOR STRETCH	(*)								
	SLEEVES	(*)								
	SETTING AND INJECTORS CLEANING	(**)								
	FUEL PIPES									
	RUBBER INTAKE HOSE (AIR FILTER – INTAKE MANIFOLD)									
	INTERIOR RADIATOR CLEANING									
	ALTERNATOR AND STARTER MOTOR									
REPLACEMENT	ENGINE LUBRICANT	(*) (°)								
	OIL FILTER	(*)								
	FUEL FILTER	(*)								
	ALTERNATOR FAN BELT	(**)								
	COOLANT LEVEL	(**)								
	PARTIAL OVERHAUL									
	TOTAL OVERHAUL									
	FUEL PIPES	(**)								
	RUBBER INTAKE HOSE (AIR FILTER – INTAKE MANIFOLD)	(**)								
	SLEEVES	(**)								
	DRY AIR CLEANER EXTERNAL CARTRIDGE	(***)	AFTER 6 CHECKS WITH CLEANING							
	DRY AIR CLEANER INTERNAL CARTRIDGE	(***)	AFTER 3 CHECKS WITH CLEANING							

200 STANDARD OIL SUMP

300 ENHANCED OIL SUMP

(*) - In case of low use: every year.

(**) - In case of low use: every 2 years.

(***) - The period of time that must elapse before cleaning or replacing the filter element depends on the environment in which the engine operates. The air filter must be cleaned and replaced more frequently in very dusty conditions.

(°) - If you are using oil of a quality lower than the prescribed one then you will have to replace it every 125 hours for the standard sump and every 150 hours for the enhanced sump.

LUBRICANT

SAE Classification

In the SAE classification, oils differ on the basis of their viscosity, and no other qualitative characteristic is taken into account.

The first number refers to the viscosity when the engine is cold (symbol W = winter), while the second considers viscosity with the engine at régime.

The criteria for choosing must consider, during winter, the lowest outside temperature to which the engine will be subject and the highest functioning temperature during summer.

Single-degree oils are normally used when the running temperature varies scarcely.

Multi-degree oil is less sensitive to temperature changes.

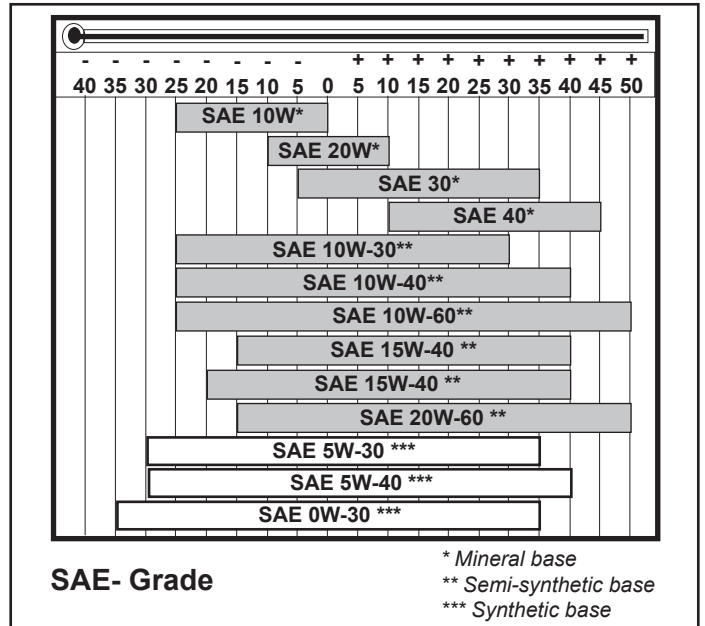

International specifications

They define testing performances and procedures that the lubricants need to successfully respond to in several engine testing and laboratory analysis so as to be considered qualified and in conformity to the regulations set for each lubrication kind.

A.P.I : (American Petroleum Institute)

MIL : Engine oil U.S. military specifications released for logistic reasons

ACEA : European Automobile Manufacturers Association

Tables shown on this page are of useful reference when buying a kind of oil.

Codes are usually printed-out on the oil container and the understanding of their meaning is useful for comparing different brands and choosing the kind with the right characteristics.

Usually a specification showing a following letter or number is preferable to one with a preceding letter or number.

An SF oil, for instance, is more performing than a SE oil but less performing than a SG one.

ACEA Regulations - ACEA Sequences

PETROL

A1 = Low-viscosity, for frictions reduction

A2 = Standard

A3 = High performances

LIGHT DUTY DIESEL ENGINES

B1 = Low-viscosity, for frictions reduction

B2 = Standard

B3 = High performances (indirect injection)

B4 = High quality (direct injection)

HEAVY DUTY DIESEL ENGINES

E1 = OBSOLETE

E2 = Standard

E3 = Heavy conditions (Euro 1 - Euro 2 engines)

E4 = Heavy conditions (Euro 1 - Euro 2 - Euro 3 engines)

E5 = High performances in heavy conditions (Euro 1 - Euro 2 - Euro 3 engines)

API / MIL Sequences

	DIESEL								PETROL								
API	CH-4	CG-4	CF-4	CF-2	CF	CE	CD	CC	SC	SD	SE	SF	SG	SH	SJ	SL	
MIL			L- 46152 D / E														

PRESCRIBED LUBRICANT
AGIP SINT 2000 TURBODIESEL 5W40

specifications

**API CF - SH
ACEA B3-B4
MIL - L-2104 C
MIL-L-46152 D**

In the countries where AGIP products are not available, use oil API CF/SH for Diesel engines or oil corresponding to the military specification MIL-L-2104 C/46152 D.

CHD ENGINES OIL CAPACITY			KDW 1603	KDW 2204 - 2204/T
OIL VOLUME AT MAX LEVEL (OIL FILTER INCLUDED)	Sheet STD oil sump.	Litres	4.4	6.4 - 5.3*
	ENHANCED aluminium oil sump.		7.1	9.5
OIL VOLUME AT MAX LEVEL (WITHOUT OIL FILTER)	Sheet STD oil sump.	Litres	3.8	5.7 - 4.5*
	ENHANCED aluminium oil sump.		6.4	8.8

* With dynamic balancer

Important

If you are using oil of a quality lower than the prescribed one then you will have to replace it every 125 hours for the standard sump and every 150 hours for the enhanced sump.

Danger – Attention

- The engine may be damaged if operated with insufficient lube oil. It is also dangerous to supply too much lube oil to the engine because a sudden increase in engine rpm could be caused by its combustion.
- Use proper lube oil preserve your engine. Good quality or poor quality of the lubricating oil has an affect on engine performance and life.
- If inferior oil is used, or if your engine oil is not changed regularly, the risk of piston seizure, piston ring sticking, and accelerated wear of the cylinder liner, bearing and other moving components increases significantly.
- Always use oil with the right viscosity for the ambient temperature in which your engine is being operated.

Danger – Attention

- The used engine oil can cause skin-cancer if kept frequently in contact for prolonged periods.
- If contact with oil cannot be avoided, wash carefully your hands with water and soap as soon as possible.
- Do not disperse the oil in the ambient, as it has a high pollution power.

COOLANT



Danger – Attention

- The fluid coolant circuit is pressurized. Inspections must only be made when the engine has cooled and even in this case, the radiator or expansion chamber plug must be unscrewed with the utmost caution.
- If an electric fan is installed, do not approach a hot engine since the fan itself could start up even when the engine is at a standstill.
- Coolant fluid is polluting, it must therefore be disposed of in the correct way. Do not litter.

The anti-freeze protection liquid (**AGIP ANTIFREEZE SPEZIAL**) must be used mixed with water, preferably decalcified. The freezing point of the cooling mixture depends on the product concentration in water, it is therefore recommended to use a 50% diluted mixture which guarantees a certain degree of optimal protection. As well as lowering the freezing point, the permanent liquid also raises the boiling point.

Prescribed coolant.

**50% AGIP ANTIFREEZE
SPEZIAL**
50% Water

Coolant refueling

ENGINE TYPE	KDW 1603	KDW 2204	KDW 2204/T
CAPACITY (Litres) Without radiator	4.00	5.50	5.70

For information concerning the capacity of Kohler radiators, please contact Kohler directly.
The total volume for refilling the cooling liquid varies according to the type of engine and radiator.

SPECIFICATIONS FUEL

Purchase diesel fuel in small quantities and store in clean, approved containers. Clean fuel prevents the diesel fuel injectors and pumps from clogging. Do not overfill the fuel tank.
Leave room for the fuel to expand. Immediately clean up any spillage during refueling.

Never store diesel fuel in galvanized containers; diesel fuel and the galvanized coating react chemically to each other, producing flaking that quickly clogs filters or causes fuel pump or injector failure.

High sulfur content in fuel may cause engine wear. In those countries where diesel has a high sulfur content, it is advisable to lubricate the engine with a high alkaline oil or alternatively to replace the lubricating oil recommended by the manufacturer more frequently. The regions in which diesel normally has a low sulfur content are Europe, North America, and Australia.

PRESCRIBED LUBRICANT	
Fuel with low sulphur content	API CF4 - CG4
Fuel with high sulphur content	API CF

FUEL TYPE

For best results, use only clean, fresh, commercial-grade diesel fuel. Diesel fuels that satisfy the following specifications are suitable for use in this engine: ASTM D-975 - 1D or 2D, EN590, or equivalent.

FUELS FOR LOW TEMPERATURES

It is possible to run the engine at temperatures below 0°C using special winter fuels. These fuels reduce the formation of paraffin in diesel at low temperatures. If paraffin forms in the diesel, the fuel filter becomes blocked interrupting the flow of fuel.

Fuel can be:

- Summer up to 0°C
- Winter up to -10°C
- Alpine up to -20°C
- Arctic up to -30°C

BIODIESEL FUEL

Fuels containing less than 20% methyl ester or B20, are suitable for use in this engine. Biodiesel fuels meeting the specification of BQ-9000 or equivalent are recommended. DO NOT use vegetable oil as a biofuel for this engine.

Any failures resulting from the use of fuels other than recommended will not be warranted.

AVIATION FUEL

Aviation fuels suitable for use in this engine include JP5, JP4, JP8 and, JET-A (if 5 percent oil is added).

EMISSION CONTROL INFORMATION

**LOW SULFUR FUEL OR
ULTRA LOW SULFUR FUEL ONLY**

EPA /CARB emission label must be attached near the fuel inlet.

Regulations for lifting the engine



Important

- Before removing the engine from the vehicle on which it is installed, disconnect the power supply, detach the fuel and coolant supply, and all connections including the mechanical ones.
- Attach the engine to a suitable lifting device (lifting beam).
- Hook the lifting device in the engine lifting points, as shown in the figure.
- Before lifting, make sure the weight is correctly balanced by checking its barycentre.
- Close all engine openings accurately (exhaust, intake, etc.), then wash the outside and dry with a jet of compressed air.

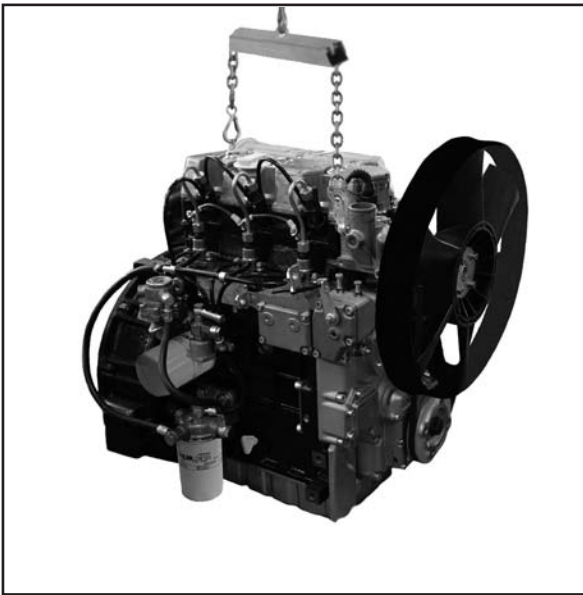

Important

The bracket of the lifting points have been designed to lift the engine only. They are not intended nor approved to lift additional weights. Do not use different methods to lift the engine than those described herein. In case different methods are used, no warranty shall be granted for any consequential damage.

Use protective gloves when handling the engine

RECOMMENDATIONS FOR DISASSEMBLING AND ASSEMBLING**Important**

To locate specific topics, the reader should refer to the index.

- Besides disassembly and reassembly operations this chapter also includes checking and setting specifications, dimensions, repair and operating instructions.
- Always use original KOHLER spare parts for proper repair operations.
- The operator must wash, clean and dry components and assemblies before installing them.
- The operator must make sure that the contact surfaces are intact, lubricate the coupling parts and protect those that are prone to oxidation.
- Before any intervention, the operator should lay out all equipment and tools in such a way as to enable him to carry out operations correctly and safely.
- For safety and convenience, you are advised to place the engine on a special rotating stand for engine overhauls.
- Before proceeding with operations, make sure that appropriate safety conditions are in place, in order to safeguard the operator and any persons involved.
- In order to fix assemblies and/or components securely, the operator must tighten the fastening parts in a criss-cross or alternating pattern.
- Assemblies and/or components with a specific tightening torque must initially be fastened at a level lower than the assigned value, and then subsequently tightened to the final torque.

RECOMMENDATIONS FOR OVERHAULS AND TUNING**Important**

To locate specific topics, the reader should refer to the index.

- Before any intervention, the operator should lay out all equipment and tools in such a way as to enable him to carry out operations correctly and safely.
- The operator must comply with the specific measures described in order to avoid errors that might cause damage to the engine.
- Before carrying out any operation, clean the assemblies and/or components thoroughly and eliminate any deposits or residual material.
- Wash the components with special detergent and do not use steam or hot water.
- Do not use flammable products (petrol, diesel, etc.) to degrease or wash components. Use special products.
- Dry all washed surfaces and components thoroughly with a jet of air or special cloths before reassembling them.
- Apply a layer of lubricant over all surfaces to protect them against oxidation.
- Check all components for intactness, wear and tear, seizure, cracks and/or faults to be sure that the engine is in good working condition.
- Some mechanical parts must be replaced *en bloc*, together with their coupled parts (e.g. valve guide/valve etc.) as specified in the spare parts catalogue.

**Danger - Attention**

During repair operations, when using compressed air, wear eye protection.

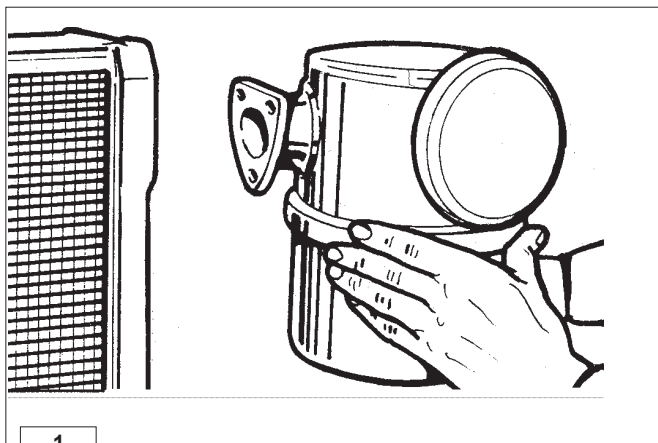

1

Oil-bath air cleaner



Danger – Attention

Never clean the filtering element 6 using solvents with a highly flash point. This could cause an explosion !



Caution – Warning

During repair operations, when using compressed air, wear eye protection.

Check gaskets and replace if necessary.
Check that flange welds are free of porosity or defective spots.
Carefully clean bowl and filtering element with Diesel fuel and dry with compressed air.
Top up engine oil to the mark (see below).
When refitting tighten nuts to 25 Nm
See page 22 for periodic cleaning and oil replacement.

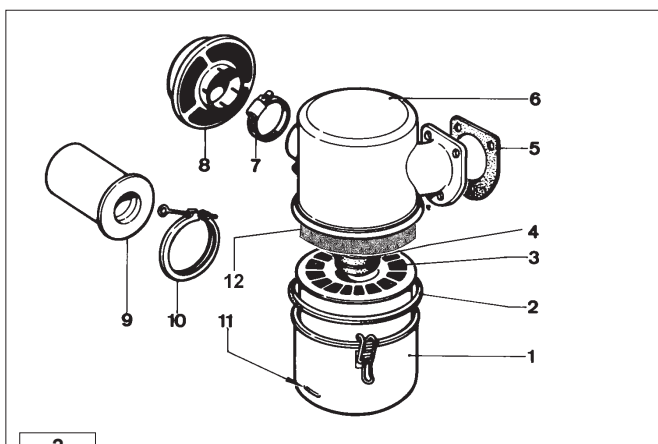

2

Oil-bath air cleaner components



Important

Check the sealing rings regularly.
Replace the sealing rings if hardening or damage is noted

- 1 Bowl
- 2 Outer seal ring
- 3 Lower filtering element
- 4 Inner seal ring
- 5 Gasket
- 6 Cover
- 7 Cap clamp
- 8 Cap
- 9 Centrifugal pre-filter
- 10 Centrifugal pre-filter clamp
- 11 Oil level mark
- 12 Upper filtering element (polyurethan sponge)

Note: Centrifugal pre-filter 9 is fitted upon request.

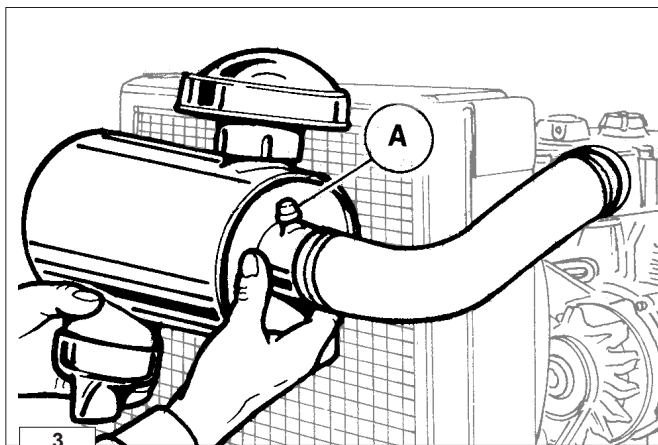

3

Dry air cleaner



Danger – Attention

Never clean the filtering element using solvents with a low flash point. This could cause an explosion !

A = Fitting to accomodate clogging indicator

See page 22 for periodic dry air cleaner check and replacement and the rubber intake hose (air filter - intake manifold).

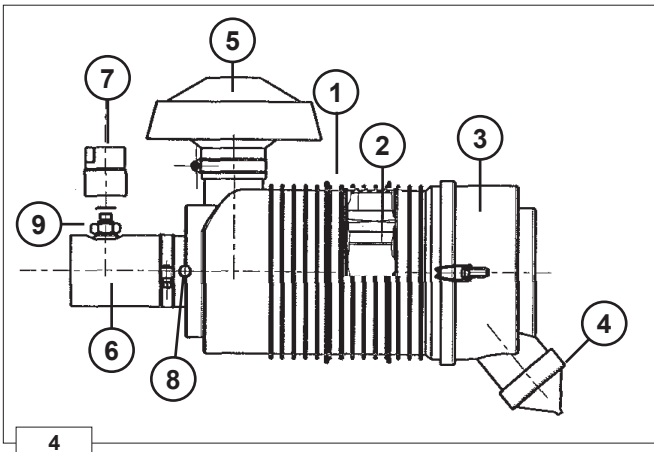

Dry air components

- 1 Main cartridge
- 2 Safety cartridge
- 3 Axial cover
- 4 Vacuator valve
- 5 Cap complete with clamp
- 6 Rubber connecting hose to the air filter - manifold or compressor.
- 7 Air filter restriction switch
- 8 Mounting for clogging indicator
- 9 Fastener

Scavenging valve 4 must be positioned as in figure 4.

The cartridge can be cleaned by blowing compressed air breadthways outside and inside the cartridge, at a pressure not greater than 5 atmospheres, or in necessity case by knocking the front of the cartridge several times against a flat surface.

Use a lamp to check that the filter element is not damaged or inspect it against the light while slanted. In case of doubt, install a new cartridge.

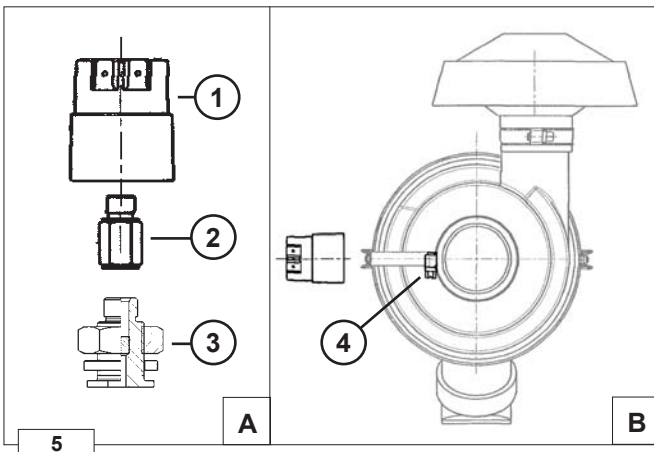

Air filter clogging indicator



Important

The indicator has to be tightened to mounting 4, as shown in fig. 5 B. Due to space requirements, it can be assembled by using special fastener 3 (fig. A) and by creating a hole of Ø14-15 mm in the rubber hose (see fig. 4).

- 1 Air filter restriction switch
- 2 Turbo adapter
- 3 Fastener
- 4 Mounting for clogging indicator

Note: There are two types: one for an aspirated engine and one for a supercharged engine.

Setting for aspirated engine(KDW 1603 - 2204) = 635 mm column of water.

Setting for supercharged engine (KDW 2204/T) = 380 mm column of water.

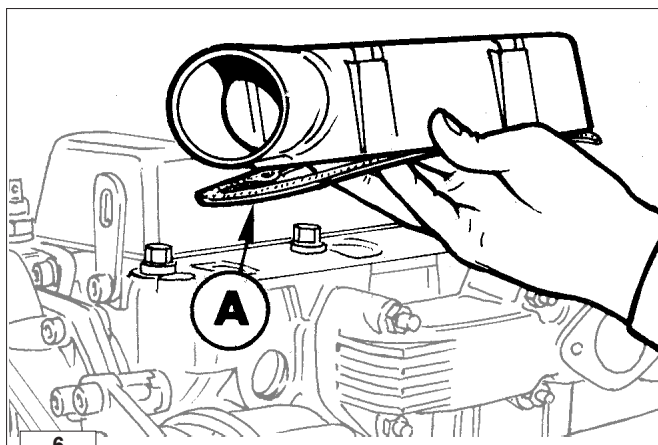

Intake manifold

The sealing surface should be clean, smooth and free of any strains and scoring.
When reassembly replace gasket **A**.

- Tighten the fastening screws to 25 Nm.

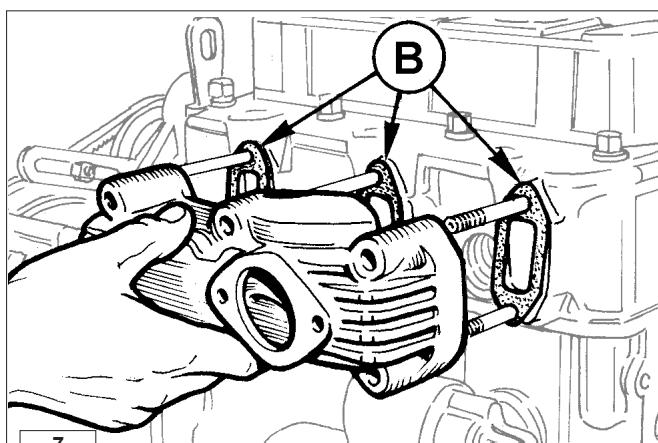

Exhaust manifold



Danger – Attention

Allow the exhaust manifold to cool before demounting it in order to prevent scorching and burns.

Verify that the seal surfaces are free of distortions and scratches and that the manifold is not broken in any way.
When refitting, replace gaskets **B**.

- Tighten nuts to 25 Nm.

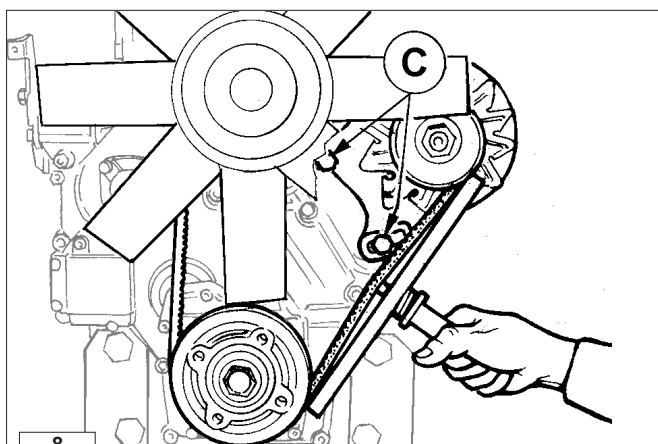

"V" belt



Danger – Attention

Check the belt tension only when the engine is not running.

Tension adjustment:
Loosen alternator fixing bolts **C**.
Stretch belt so that a 100 Nm load located half-way between the two pulleys causes a 10÷15 mm flexure.
Pull strongly alternator externally and tighten fixing bolts **C**.
The final torque must be 40 Nm.
If you use the belt tension gauge type DENSO BTG-2, the correct value of tension must be from 35÷40 Nm.

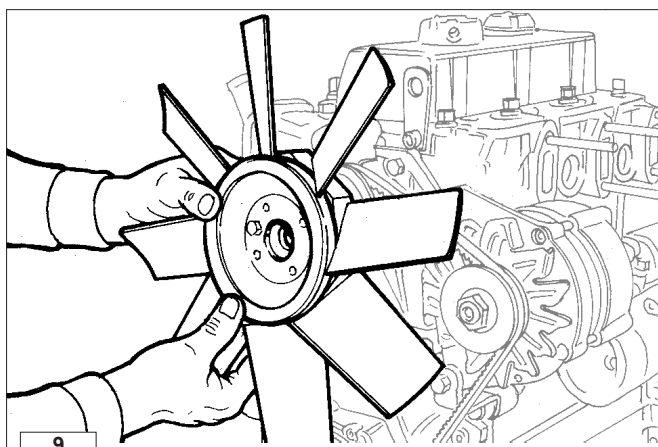

Cooling fan



Danger – Attention

Before disassembling the cooling fan, isolate the positive battery cable to prevent accidental short-circuiting and, consequently, activation of the starter motor

Take off the fan and check that all blades are not damaged; if any are damaged, replace the entire fan.
Depending on the type of application the cooling fans can be suction or blower fans and can differ in diameter.

- Tighten the fastening screws to 10 Nm.

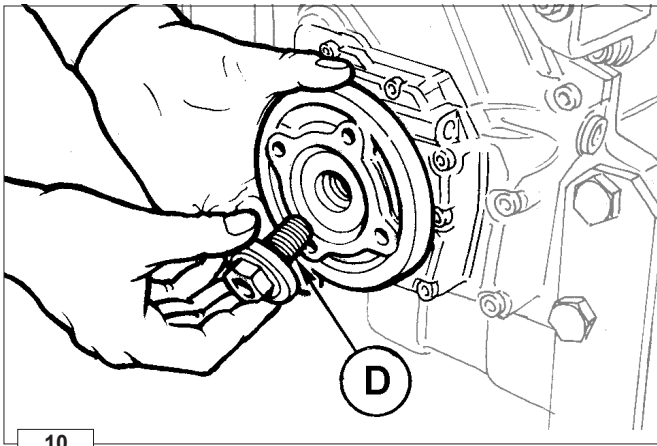

10

Driving pulley (2^a P.T.O.)

The maximum torque that can be drawn from the second power take-off must be at maximum 70 Nm.

The driving pulley drives the alternator and the water pump and consequently the cooling fan.

Bolt **D** can be loosened by turning clockwise. When refitting lubricate the bolt with Molyslip and tighten it at 360 Nm.

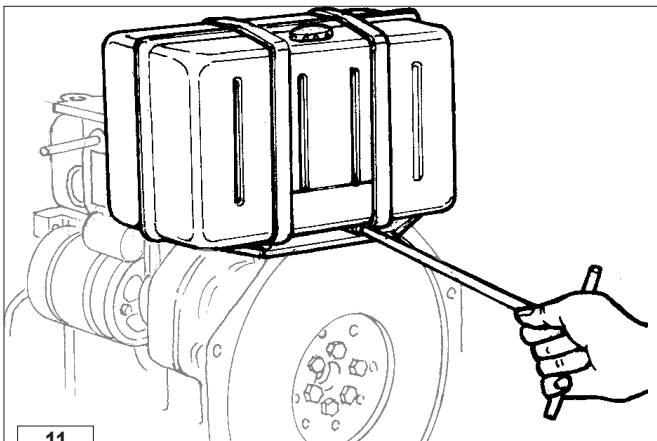

11

Tank



Danger – Attention

To avoid explosions or fire outbreaks, do not smoke or use naked flames during the operations.

Fuel vapours are highly toxic. Only carry out the operations outdoors or in a well ventilated place.

Keep your face well away from the plug to prevent harmful vapours from being inhaled. Dispose of fuel in the correct way and do not litter as it is highly polluting.

Remove fuel line and loosen clamp screws.

Completely empty the tank and check that no impurities are found inside.

Check that cap breather hole is not clogged.

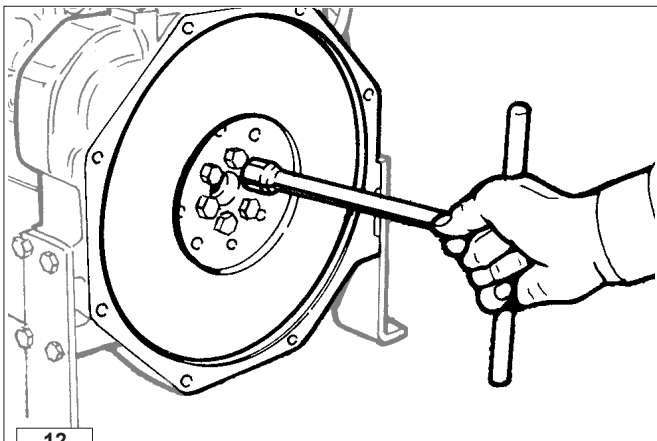

12

Flywheel



Caution – Warning

During the demounting phases, pay particular attention to prevent the flywheel from dropping as this could seriously injure the operator.

Wear protective goggles when removing the flywheel ring.

Remove the bolts which attach the flywheel to the crankshaft; when refitting tighten to 140 Nm after checking that the locating pin is in its seat. To remove the starter ring gear, it is recommended to cut it into several portions with an iron hacksaw and then use a chisel.

To remove the starter rim, it is advisable to cut it into several parts with a hacksaw and to then use a chisel. To replace, slowly heat for 15-20 minutes to a temperature of 300°C max. Fit the rim into the flywheel housing. make sure that it rests evenly against the support of the housing itself. Allow it to slowly cool.

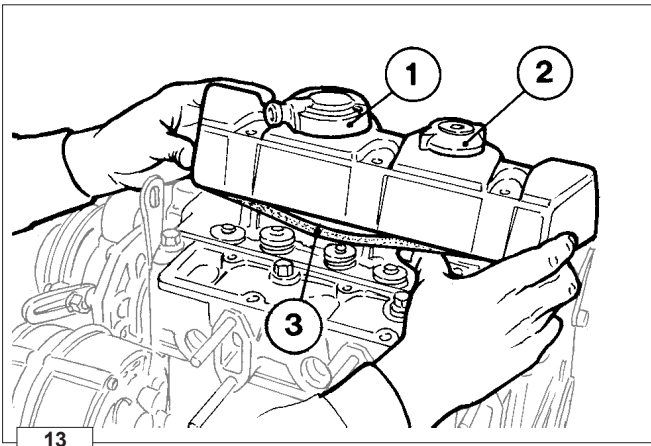

Rocker arm cover with vent into the air

Components:

- 1 - Decanting device
- 2 - Oil fill cap
- 3 - Gasket

Inside the decanting device 1 there is a small metal skin that separates the oil from the bled vapours; before reassembling it, clean it and verify its intactness.



Important

Every time the rocker arm cap is removed replace the gasket 3.

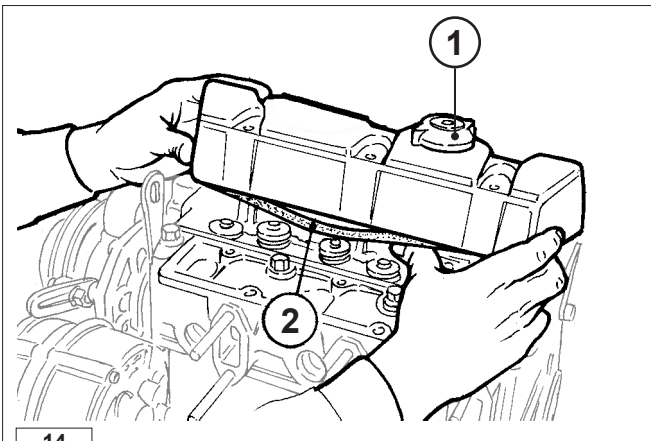

Rocker arm cover with vent into the air

Components:

- 1 - Oil fill cap
- 2 - Gasket



Important

Every time the rocker arm cap is removed replace the gasket 2.

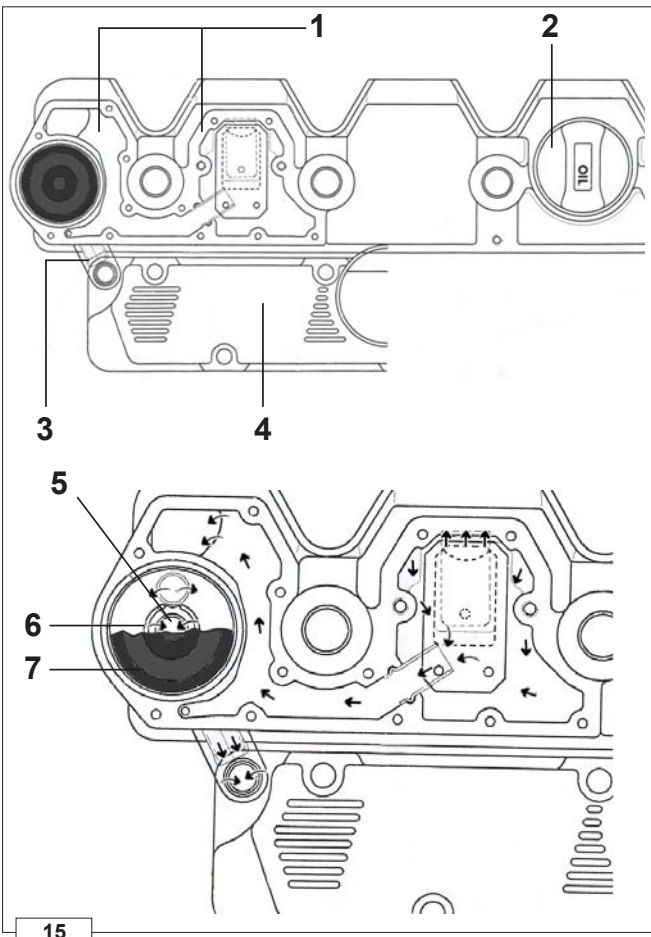

Rocker arm cover for engines with recirculating vent

Components:

- 1 - Recirculating vent system
- 2 - Oil refilling plug
- 3 - Rubber hose for the passage of the oil vapours
- 4 - Intake manifold

In the rocker arm cap we find most of the recirculating vent system 1. This device is used to separate the oil vapours and to convey them, via a rubber hose 3, into the intake manifold 4.

The vapours are then recirculated inside the engine and not released into the air as they can be polluting.

A clogged up air filter and a consequent increase in suction vacuum could cause the oil to be sucked into the combustion chamber and the engine over-revving.

This is in any case avoided as the diaphragm valve 7 by winning the resistance of spring 6 - properly calibrated - closes duct 5 and stops the oil from reaching manifold 4 via hose 3.

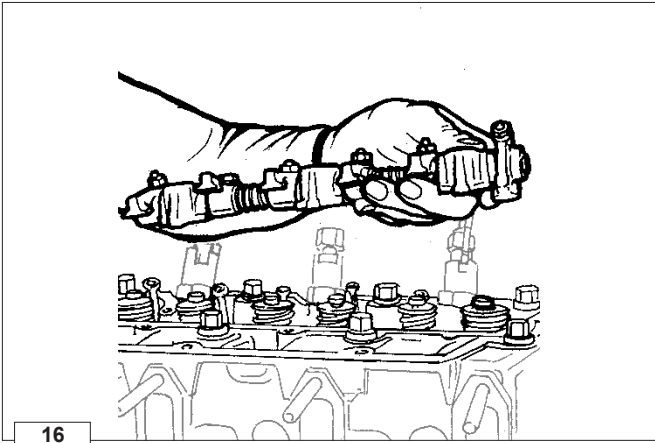

Rocker arm assembly

Loosen the screws which fasten the assembly to the head.

When refitting apply a drop of Loctite 270 onto the threads.

○ When refitting tighten to 50 Nm.

Inside the rocker arm pin flows the oil that lubricates the rocker arms and feeds the hydraulic tappets.
To clean the rocker-arm pin inside, remove the two tightening screws **C** at the ends (fig. 17).

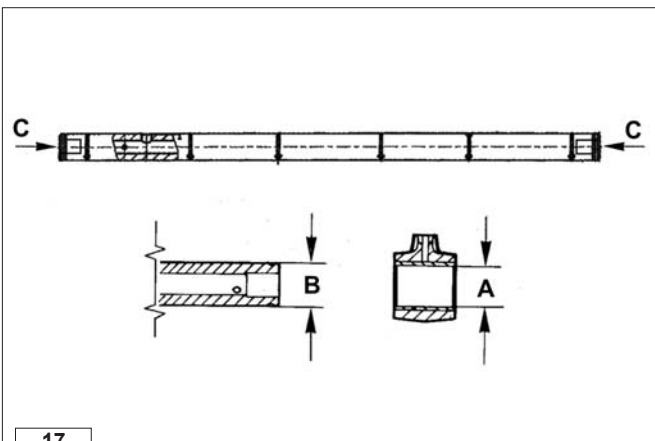

To check the pin and the rocker-arm pin bearings for wear compare the measured values with the parameters in the table below.

Table of pin-rocker arm dimensions

Ref.	Dimensions (mm)	Clearance (mm)	Limit value (mm)
Ø A*	14,032 ÷ 14,050	ØA-ØB = 0,043 ÷ 0,050	0,014
Ø B	13,989 ÷ 14,000		

* With bushing fitted to the rocker arm and reamed.

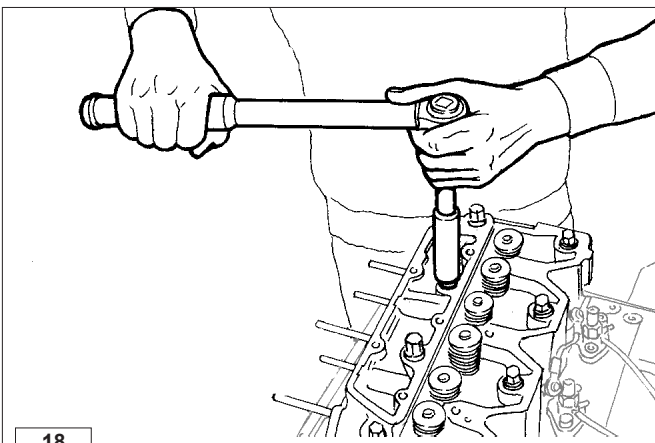

Cylinder head

 **Caution – Warning**

Do not demount when hot or the part could become deformed.

Do not remove when hot to avoid deformation.
Check cylinder head plane using a metal straight edge and thickness gauge; if warpage exceeds 0.10 mm, level off by removing a maximum 0.20 mm.

➡ See pictures 56÷59 (pages 39÷40) for cylinder head tightening.

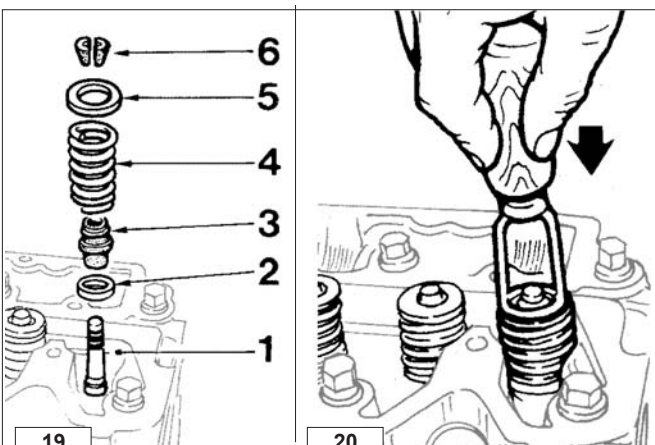

Valve removal

Components:

- 1 - Valve
- 2 - Lower spring seat
- 3 - Valve guide seal (for intake only)
- 4 - Spring
- 5 - Spring cap
- 6 - Cotters

To remove the cotters firmly press down as shown in the figure 20.

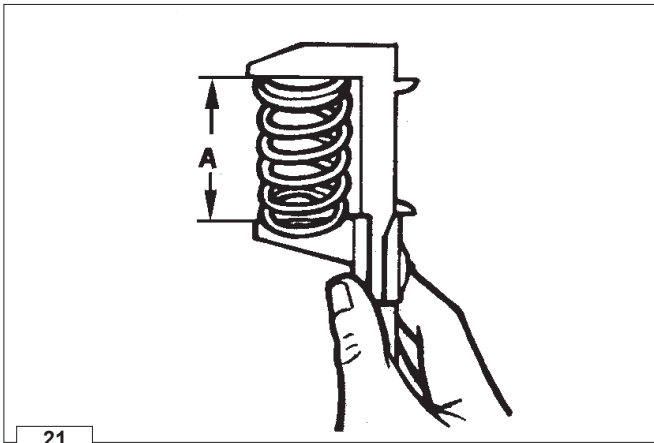

21

Valve spring - Check

Check the overall state of the valve springs. Replace if damaged or if they have lost their original elasticity. First of all, use a gauge to check that the free length matches the measurements given below.

A = 52 mm

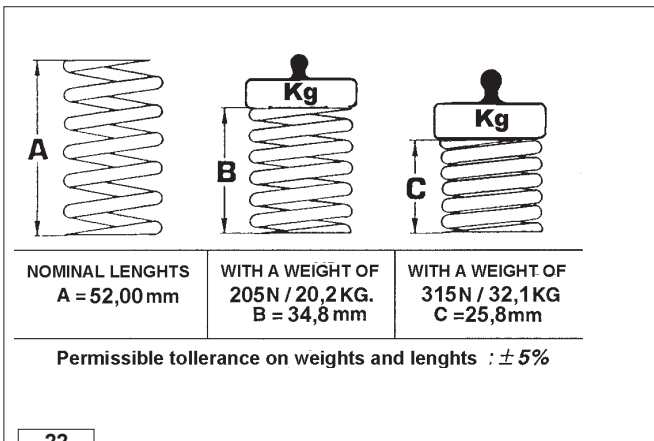

22

Valve spring - check under load

Verify (with a dynamometer) that the length under load matches the nominal length. If it is shorter than that quoted in figure 22, replace the spring.

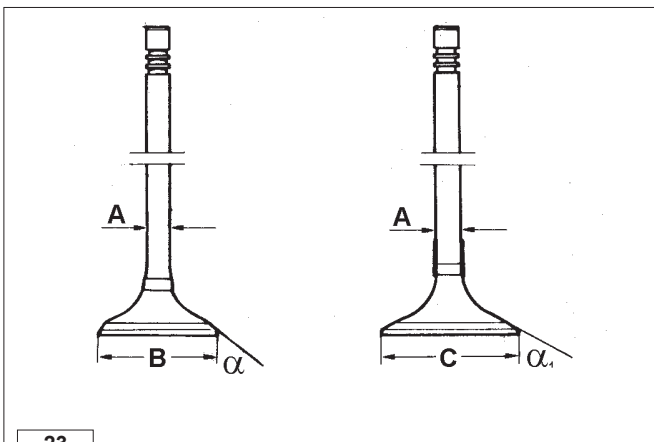

23

Valve material

Ref.	Dimensions
A	6,985 ÷ 7,00 mm
B	35,30 ÷ 35,50 mm
C	40,30 ÷ 40,50 mm
a	45° 30' ÷ 45° 45'
a ₁	60° 30' ÷ 60° 45'

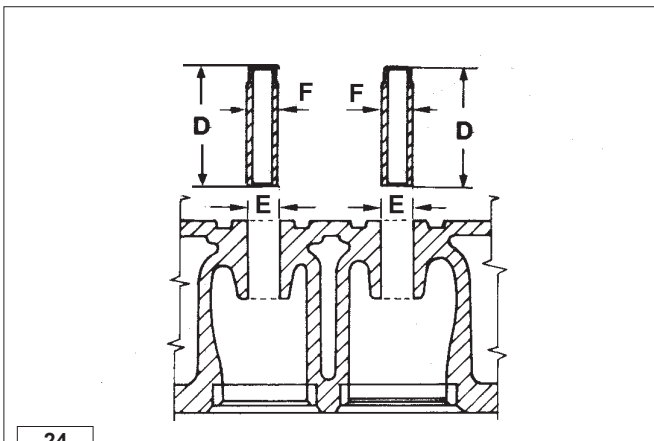

24

Valve guides and cylinder head

Intake and exhaust valve guides are both made of gray cast iron with pearlitic and phosphoric matrix.

Ref.	Dimensions (mm)
D	38,00
E	12,020 ÷ 12,038
F	12,048 ÷ 12,058

Valve guides with outside diameter **F** increased by 0.5 mm are available; in such case valve guide bore **E** should also be increased by 0.5.

Valve guide insertion, after driving

Press guides considering the **L** distance from the head plane **X**.

Ref.	Dimensions (mm)
X	7,020 ÷ 7,035
Y	7,020 ÷ 7,035
L	36,8 ÷ 37,2
A	6,985 ÷ 7,00

Ref.	Clearance (mm)	Limit value (mm)
Y-A	0,020 ÷	0,100
X-A	0,050	

The referred quote are used to control the **X-Y** concentricity between the valve seats and guides.

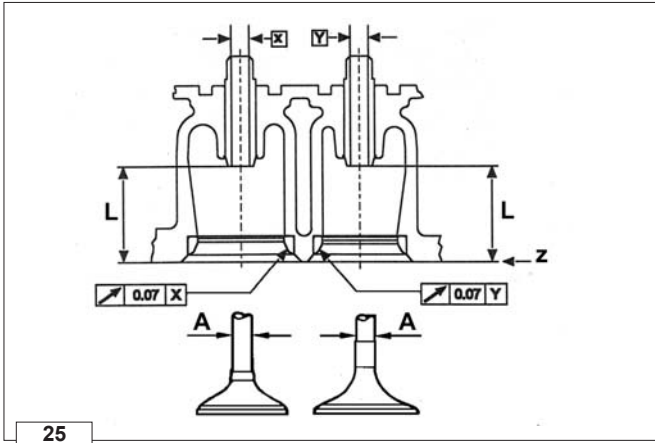

Oil seal in the valves guides, (intake and exhaust)

To prevent the seal **1** warping when mounting the valve guide **3** put it into the tool **2** part no. 7107-1460-047 and proceed as shown in the figure 27, making sure the seal **1** reaches its stop.

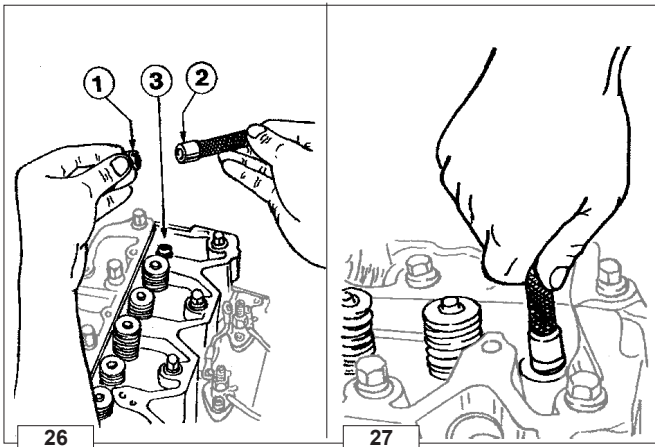

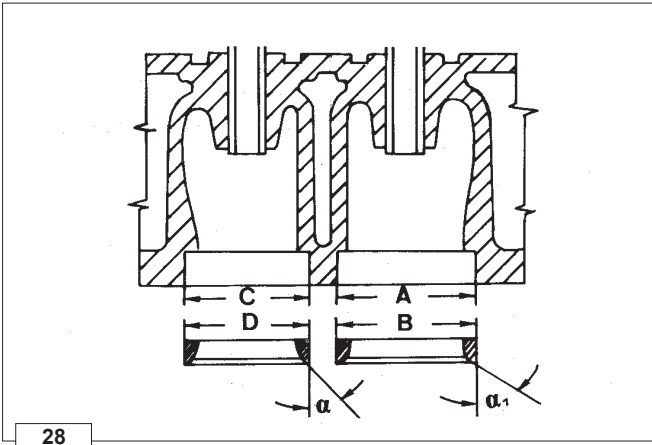

Valve seats and bore

Ref.	Dimensions
A	41,500 ÷ 41,520 mm
B	41,575 ÷ 41,590 mm
C	36,500 ÷ 36,520 mm
D	36,575 ÷ 36,590
α	44° 53' ÷ 45°
α_1	59° 53' ÷ 60°

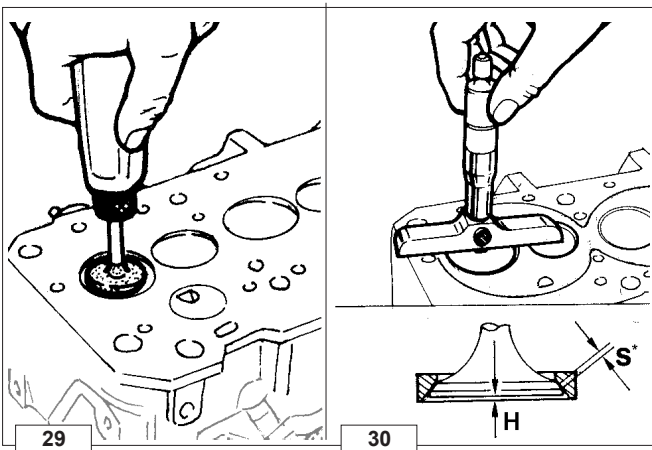

Valve recess and sealing surfaces

Ss* = Sealing surface width on exhaust side
Sa* = Sealing surface width on intake side
H = Valve recess with reference to the head plane

Ref.	Dimensions (mm)	Limit value (mm)
S s*	1,27 ÷ 1,55	2,00
S a*	1,20 ÷ 1,60	
H	0,75 ÷ 1,00	1,30

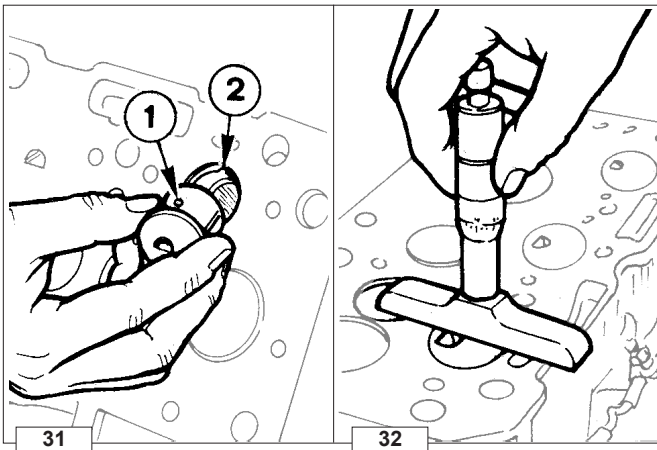

Precombustion chamber

The precombustion chamber can be extracted from the head banging with a punch into the hole from the injector housing.
 This procedure implies irreversible damages to the precombustion chamber which will have to be replaced. In the assembly stage line up the dowel **1** with the reference notch **2** located in the head.
 Driving must be carried out evenly
 The clearance allowance between the precombustion chamber and its bore on the cylinder head is equal to 0.05 mm.
 Using a depth gauge check that the precombustion chamber plane protrusion does not exceed 0.04 and does not recede over 0.02 mm from the head plane level.

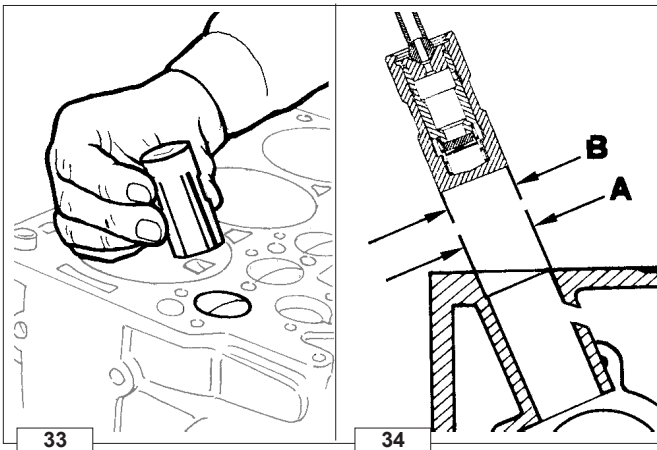

Hydraulic tappet valve control

Ref.	Dimensions (mm)	Clearance (mm)	Limit value (mm)
A	23,000 ÷ 23,021	0,040 ÷ 0,046	0,10
B	22,960 ÷ 22,975		

Nota: If tappet is worn out along diameter **B** replace it.
 No oversize tappets are available. If tappet/camshaft surface is worn - replace

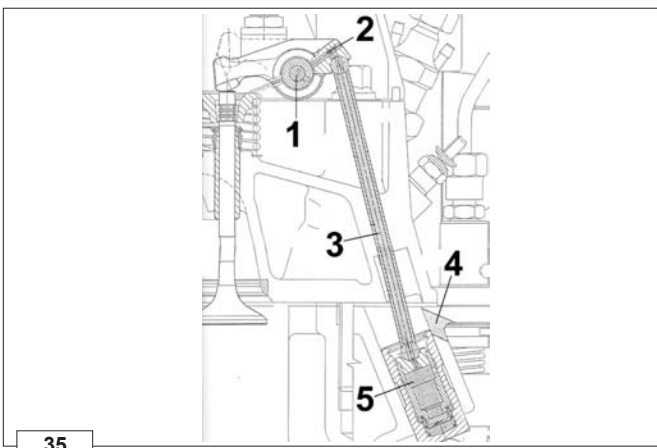

Hydraulic diagram for feeding the tappets

- 1 Rocker-arm pin
- 2 Rocker arm
- 3 Push rod
- 4 Oil drainage
- 5 Hydraulic tappet

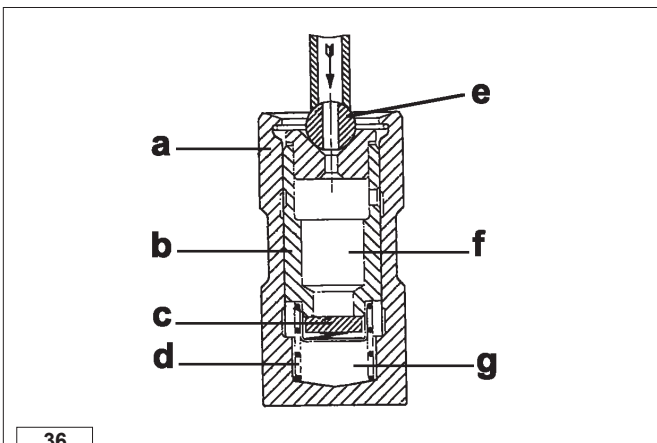

Hydraulic tappet components:

- a) Tappet body
- b) Plunger
- c) Non-return valve
- d) Spring
- e) Push rod
- f) Low-pressure chamber
- g) High-pressure chamber

The hydraulic tappet is a device that enables elimination of clearance between timing system components and provides the following advantages:

- Reduces noise levels during operation.
- Reduces wear of the timing system components, thanks to there being no collisions at the opening with consequent breaking of the oil film.
- No maintenance.

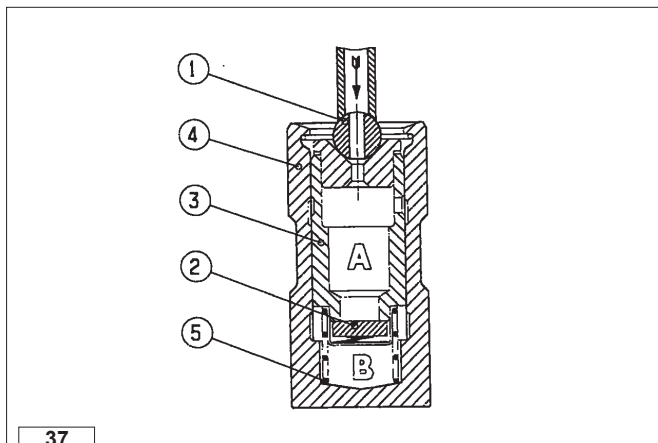

37

Hydraulic tappet operation

The operating principle of the hydraulic tappet is based on the incompressibility of the liquids and on controlled leakage.

Through push rod 1, the pressurised oil gets into the tappet in chamber A (low-pressure chamber), maintaining a constant flow of oil in the above chamber as well as in the high-pressure chamber B. The oil can only enter chamber B through the non-return valve 2 and leave through the clearance between the plunger 3 and the tappet body 4 (controlled leakage).

Chamber B is refilled when the tappet is on the bottom of the cam base and spring 5 keeps plunger 3 pressed, thus eliminating the clearance in the entire valve-rocker arm-push rod-tappet-cam system.

The tappet body moves away from the plunger creating a slight vacuum in chamber B and causing the valve 2 to open, thus allowing the oil in chamber A to flow into chamber B, re-establishing the quantity of oil required for optimal running conditions.

Difficult operating conditions:

For correct functioning of the hydraulic tappets the pressure chamber of plunger 3 must always be filled with oil. However, this is not possible in some conditions in that, when the engine is not running, oil leakages may cause partial emptying of the tappets. This situation will cause excessive clearance which will make itself apparent through an unusual ticking sound that is not to be confused with the normal ticking of the injectors.

- 1 -Starting from cold: the engine has not been used for some time and oil may have leaked out of the pressure chamber of the tappets. Moreover, lubricant flows with greater difficulty at low temperatures, and hence several seconds may go by before the tappets are once again supplied with oil.
- 2 -Engine very hot: at minimum speed, the oil pressure is low and tiny air bubbles may form inside it (more than 5% of its volume). This causes the lubricant to become compressible and the tappet is squeezed slightly creating clearance and, thus making a noise.
- 3 - Starting and stopping the engine repeatedly (very rare): in this situation the tappets may empty temporarily.
- 4 - An oil with a viscosity not adequate to the environmental conditions of the engine may affect the proper functioning of the hydraulic tappets.

For the determination of the adequate viscosity of oil referred to page. 29.

In all four cases the ticking should not last too long. If this is not the case, the problem is definitely due to a manufacturing fault, wear and tear or dirt, which can be drawn in by the oil and get between the non-return valve and its seat inside the plunger, thus compromising the functioning of the tappets. In this case the hydraulic tappets must be replaced.

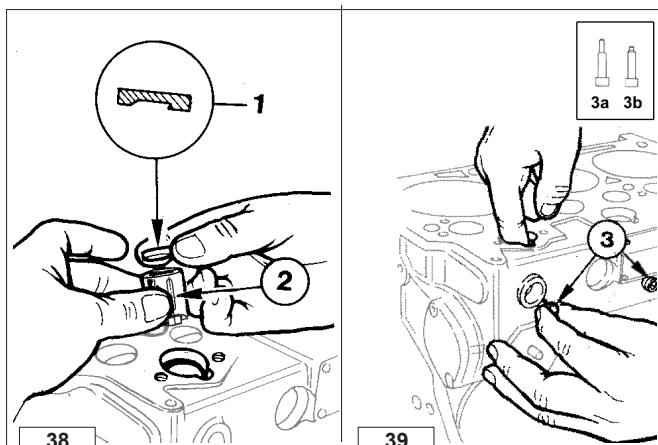

38

39

Injection pump follower

Introduce the follower into its housing and manually turn screw 3 until it matches with notch 2.

Before locking screw 3 use your finger to check that the follower is allowed to move upwards freely.

Space 1 should be introduced into the pushrod with the flat surface facing upwards

Note: The screws 3a can be fitted without distinction in each cylinder.

Screw 3b however, which is shorter than the others, has to be fitted on the timing side of the cylinder (inside the stop lever cover).

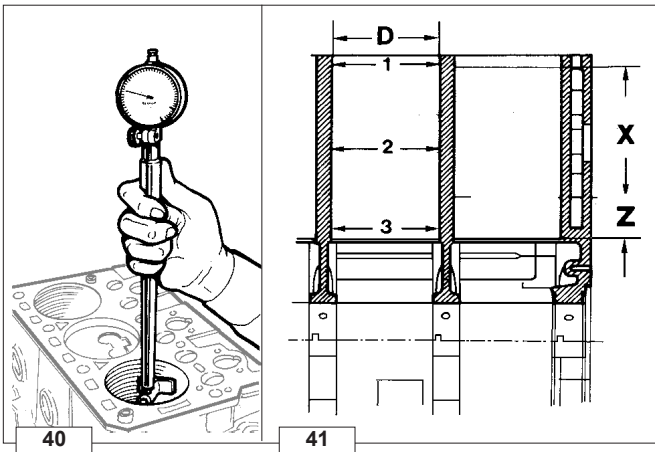

Cylinders

Reset dial gauge with a calibrated ring.
Check diameter size **D** at **1**, **2** and **3**; repeat the same operation at the same places after turning the dial gauge by 90°.
Check for wear in the **X** area where piston rings are located.

D (mm)	Limit value (mm)
88,00 ÷ 88,01	88,100

To check clearance with the matching piston measure the diameter size at **Z** along the axis which runs at right angles to the driving shaft.

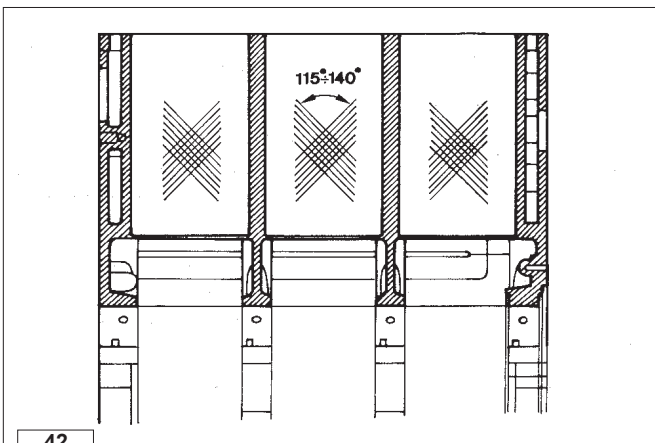

Cylinder roughness



Important

Do not manually hone the cylinder bore surfaces with emery cloth or other means.

The inclination of the cross-hatched marks left by machining should range between 115°-140°; they should be uniform and clearly visible in both directions.

Average roughness should range between 0.5 and 1 mm.

The cylinder surface which comes into contact with the piston rings should be machine honed with the plateau system.

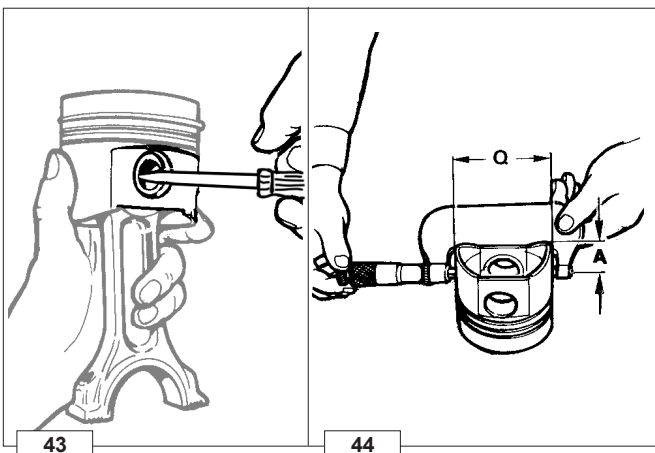

Piston

Remove circlips and piston pin.

Remove piston rings and clean grooves.

Measure diameter **Q** at the **A** distance from the bottom of the skirt (**A** = 12 mm)

In case of diameter wear exceeding 0.05 mm of the minimum given value replace piston and rings.

Nota: The oversizes are 0.50 and 1.00 mm. The TURBO piston differs from that of the NATURALLY ASPIRATED in its cooling sprayer passage niche and an insert in the slot of the first ring.

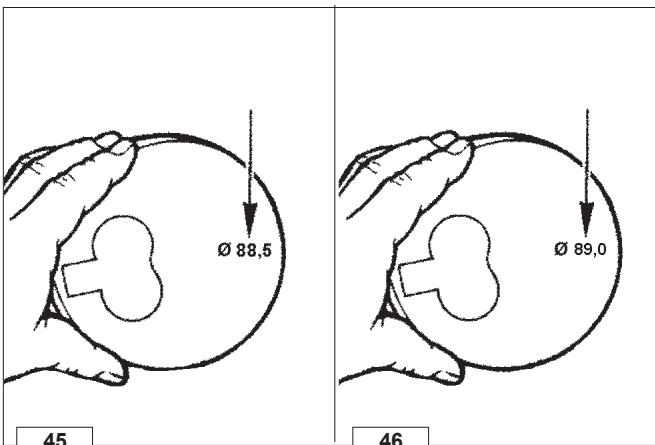

Piston availability

The pistons oversized by 0.5 and 1.0 mm have the uprating reference on the crown, fig. 45-46.

Class	Ø Cylinder (mm)	Ø Piston (mm)	Clearance (mm)
A	88,00 ÷ 88,01	87,960 ÷ 87,967	0,033 ÷ 0,050

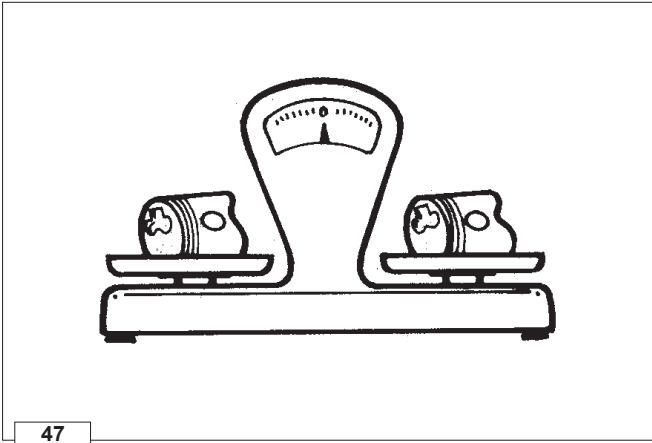

47

Piston weight

Weigh the pistons when replacing them in order to avoid unbalance.
The difference in weight should not exceed 6 g.

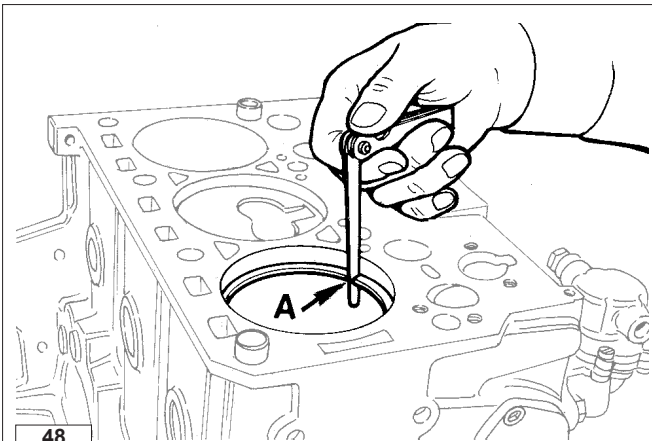

48

Piston rings - End gaps

Place piston rings into the cylinder and measure end gap **A**.

1st ring	A = 0,30 ÷ 0,50 mm
2nd ring	A = 0,30 ÷ 0,50 mm
3rd ring	A = 0,20 ÷ 0,50 mm

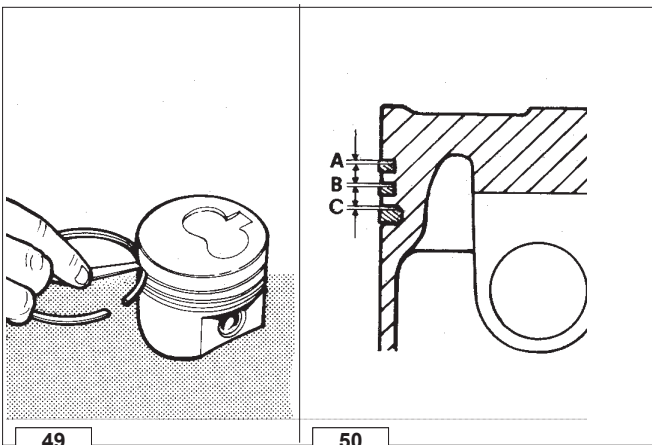

49

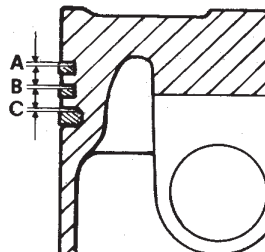

50

Piston rings - Clearance between grooves

Ref.	KDW 1603	KDW 2204 - 2204/T
A	0,07 ÷ 0,12 mm	A*
B	0,02 ÷ 0,08 mm	0,06 ÷ 0,95 mm
C	0,05 ÷ 0,08 mm	0,05 ÷ 0,08 mm

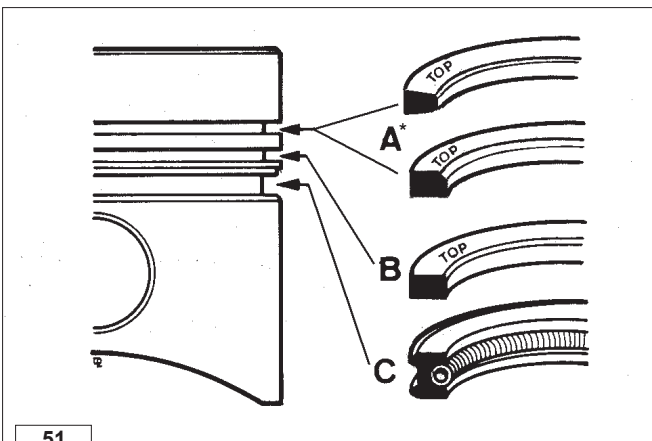

51

Piston rings - Fitting sequence

A* = 1st chrome plated compression ring *
B = 2nd tapered compression ring *
C = 3rd spiral spring oil scraper ring

* The first ring in the TURBO engine is different from the NATURALLY ASPIRATED version, it has a trapezoidal cross-section.

Assemble the segments with the TOP marking facing the piston crown.

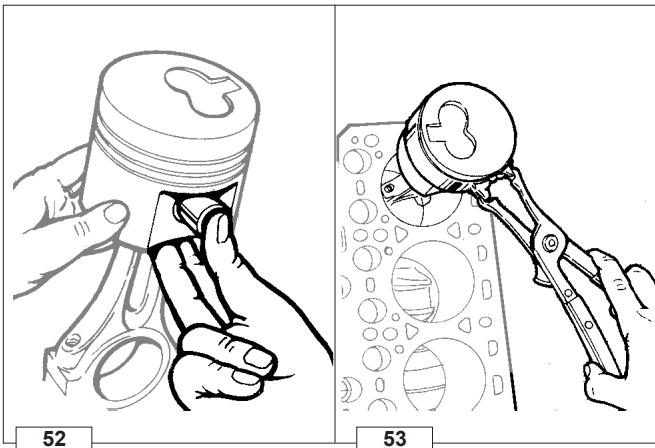

Piston - Refitting

Connect piston to connecting rod after lubricating piston pin and introducing it by exerting pressure with your thumb.
Position the two piston pin circlips and check that they are well inside their seats.
Using a ring compressor introduce the piston into the cylinder with combustion chamber facing the injection pump side.

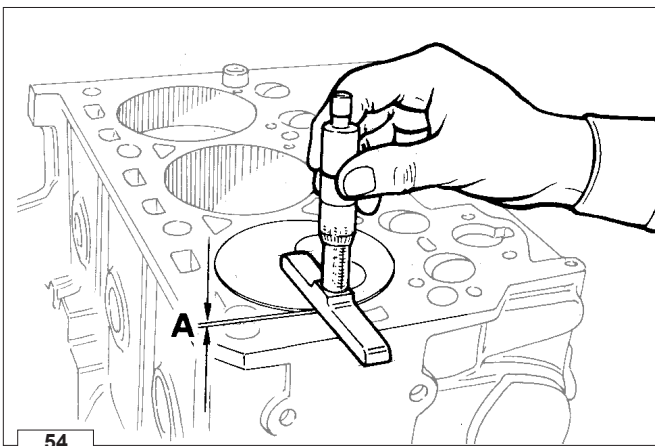

Piston position and clearance

To obtain a clearance of 0.67÷0.90 mm measure protrusion **A** of all pistons from the cylinder plane and consider the **A** value of the most protruding piston.
Perform this measurement along the engine axis.

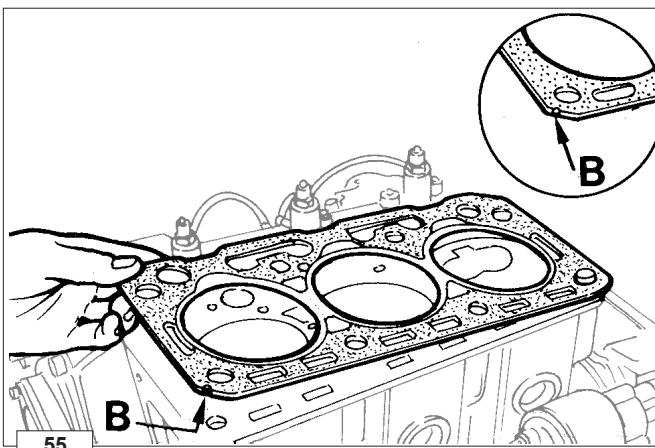

Cylinder head gasket

Caution - Warning
Remove the head gasket from its protective wrapping only when ready for fitting.

At **B** the gasket shows small semi-circular notches indicating thickness.
Choose the proper head gasket considering that for each value of **A** (maximum projection of the piston from the cylinder surface) there is a matching gasket among the three available (with no notch, one notch or two notches) to achieve a clearance volume between 0.66 and 0.90 mm.
In the LDW 1603 engines the head gasket is made of fibre, while in the LDW 2204 / 2204-T engines the head gasket is metal.

Engine type	A (mm)	No. of notches	Resulting clearance (mm)
1603	0,68 ÷ 0,83		0,67 ÷ 0,82
2204 - 2204/T	0,68 ÷ 0,81		0,72 ÷ 0,85
1603	0,83 ÷ 0,98		0,67 ÷ 0,82
2204 - 2204/T	0,81 ÷ 0,94		0,69 ÷ 0,82
1603	0,98 ÷ 1,10		0,67 ÷ 0,82
2204 - 2204/T	0,94 ÷ 1,07		0,66 ÷ 0,79

Note: The notches shown above protrude from the cylinder head plane; you can thus determine the gasket thickness before taking down the head.

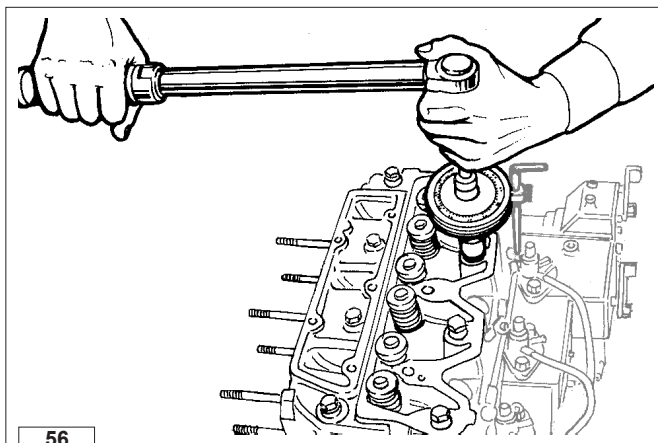

56

Cylinder head tightening for engines without hydraulic tappets

Use a torque wrench (fitted with tool for angular tightening). It is recommended to replace the screws whenever the head is disassembled.



Important

The cylinder head must never be retightened. It is advisable to lubricate the lower part of the screws with anti-seize of the type MOLYSLIP AS COMPOUND 40.

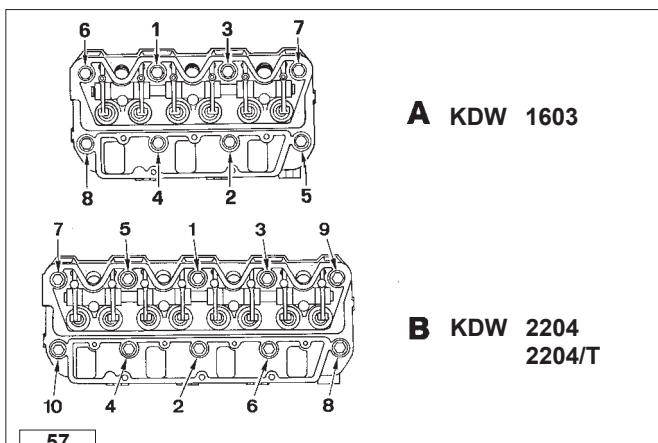

57

Cylinder head tightening steps

Following the number sequence shown in the figure 57 bolts should be tightened in four subsequent steps with the following torque values:

1st step = 40 Nm

2nd step = 70 Nm

3rd step = 100 Nm

4th steps = **For bolts 10 R:** Rotate wrench by 180° (in two steps 90°+90°)

For bolts 12 R (present only in the TURBO engines): perform a rotation of the key of 270° (in three steps, 90° + 90° + 90°).

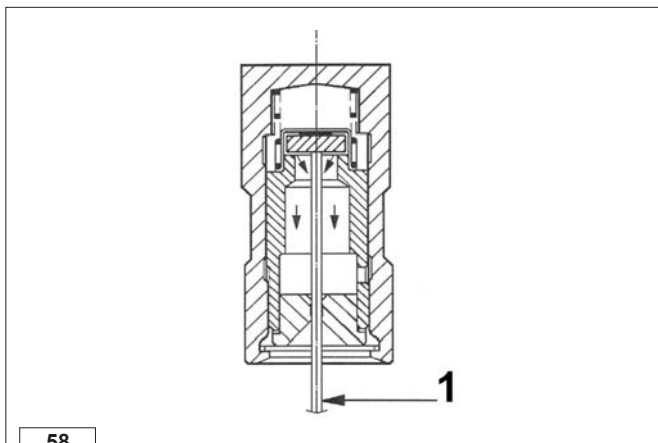

58

Assembling and tightening the cylinder head on engines with hydraulic tappets



Important

Before re-assembling the cylinder head the tappets must be removed from their housing and released.

This operation must be carried out using a pin 1.

Insert pin 1 inside the tappet and open the non-return valve.

The excess oil is released by turning the tappet upside down.

Rotate the crankshaft so as to position the pistons at half stroke for three-cylinder engines.

For four-cylinder engines, place the piston of cylinder number one at 150° after the top dead centre (in crossover stage).

Fit the head, insert the fastening screws and tighten them in the order shown in figure 57 and to their respective torques (see "Cylinder Head Tightening Stage").

Reassemble the complete pin inserting the seats of the rocker-arms on their respective rods and screw up the fastening screws of the supports by hand.



Important

To avoid bending the push rods or damaging the tappets, the fastening screws of the rocker-arm pin supports must be tightened gradually before reaching the final torque.

This procedure will give time for the excess oil in the tappets to drain away.

Each time you start to tighten up the fastening screws of the supports, you can use the upper spring support cup of the valve spring as an indicator to know how far to screw them up.

The cup must never be compressed so much that it touches the valve stem oil sealing ring fitted on the guide.

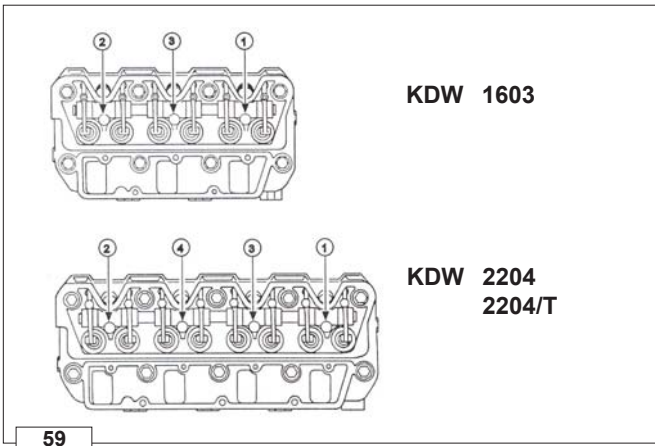

59

Tightening must be carried out as shown in figure 59. Once the final torque 50 Nm is reached, wait thirty minutes before manually rotating the engine to verify that the pistons do not collide with the valves, if the engine turns freely start the engine normally, otherwise wait another 30 minutes before repeating the operation. At first start-up the engine may run irregularly until all the air contained in the tappets has been drained.

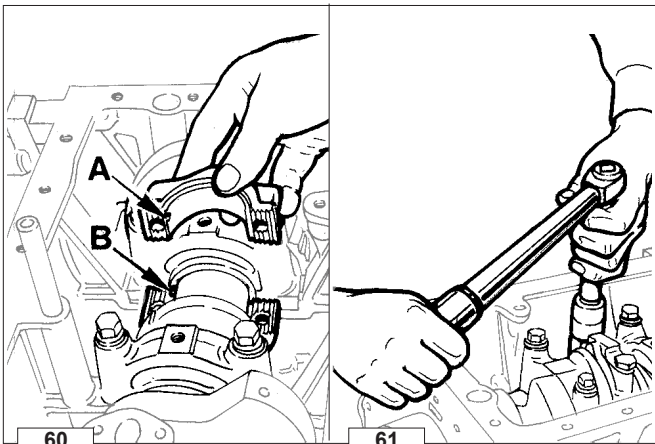

60

61

Connecting rod

Important

When remounting the big-end bearings, remember to thoroughly clean the parts and generously lubricate them to prevent seizure when the engine is started up for the first time.

Remove oil pan and oil pump suction pipe. Disconnect the connecting rod from the engine shaft and perform the subsequent checks. When refitting both centering notches A and B should be located on the same side.

- Tighten the connecting rod big end bolts to 70 Nm.

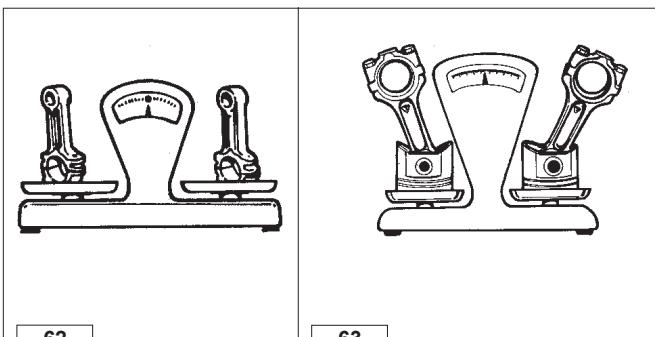

62

63

Connecting rod weights

Connecting rod, piston and piston pin can also be weighed in a preassembled state but the difference in weight should not exceed 14 g in order to avoid unbalance.

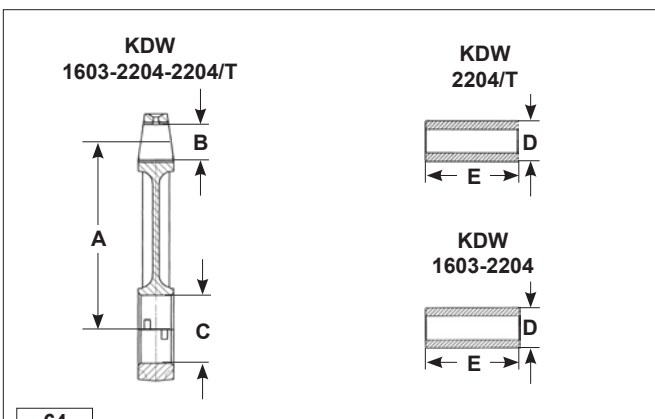

64

Connecting rod and piston pin

The connecting rod big end shell bearings are supplied in either standard or with this value decreased by 0.25 and 0.50 mm respectively.

Important

The fastening screws must be tightened by hand until the beginning of the tightening stage and then pre-tightened to 10÷15 Nm.

- Final tightening is to 70 Nm.

1603-2204-2204/T	
A	147.98 ÷ 148.02
B*	28.02 ÷ 28.03
C**	53.62 ÷ 53.78
D	27.995 ÷ 28.000
E	65.78 ÷ 65.8

Ref.	Clearance (mm)	Limit value (mm)
B - D	0,02 ÷ 0,03	0,06

Value to measure

* With driven and bored bearing.

** With cap fitted and screws tightened to a torque of 70 Nm.

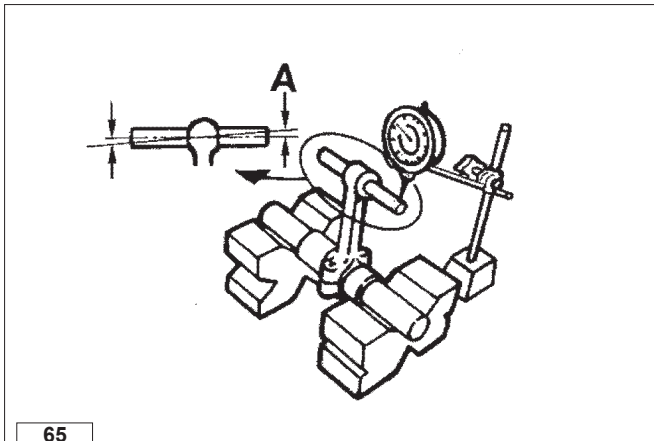

65

Connecting rod alignment

Use a surface plate and a dial gauge as shown in the figure 65. Check the alignment of the axes using the wrist pin of the piston; deviation **A** = 0.02 mm; limit = 0.05 mm. Moderate warpage may be corrected by gradually working with a press.

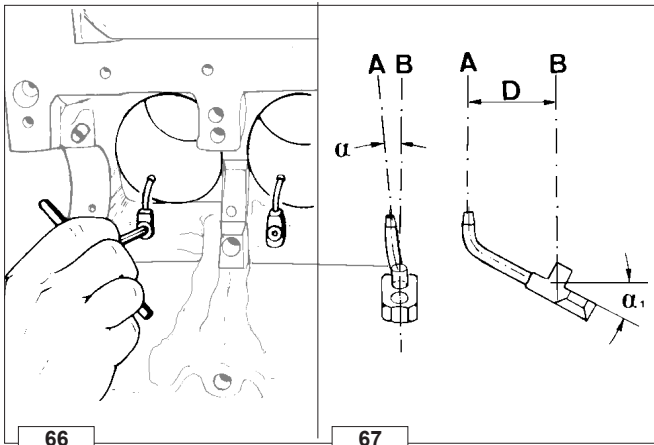

66

67

Piston cooling sprayer

This is assembled on turbo engines KDW 2204/T. Blow on it with compressed air and check that there are no impurities inside. Reassemble it back into place making sure you maintain axis alignment **A** of the spray with respect to axis **B** shown in the figure 67. Anyway the correct position is ensured by the fixing screw.

Ref.	Dimensions
α	3°
α_1	28°
D	28 mm

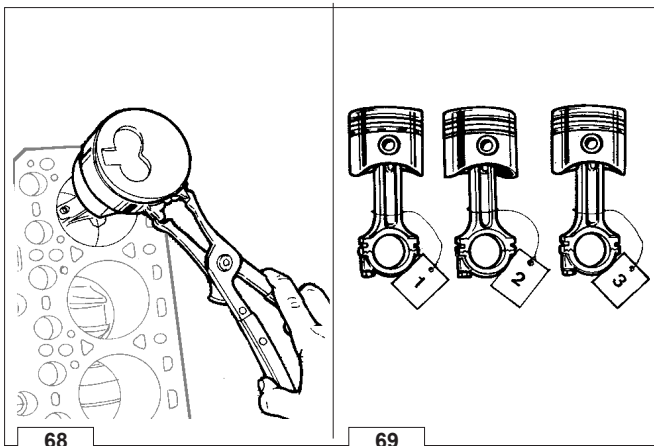

68

69

Connecting rod/piston assemblies

The three connecting rod/piston assemblies should be fitted back into their original cylinders. Mark them with references to avoid mistake.

Note: The custom at KOHLER is to consider the cylinder on the flywheel side as the first cylinder.

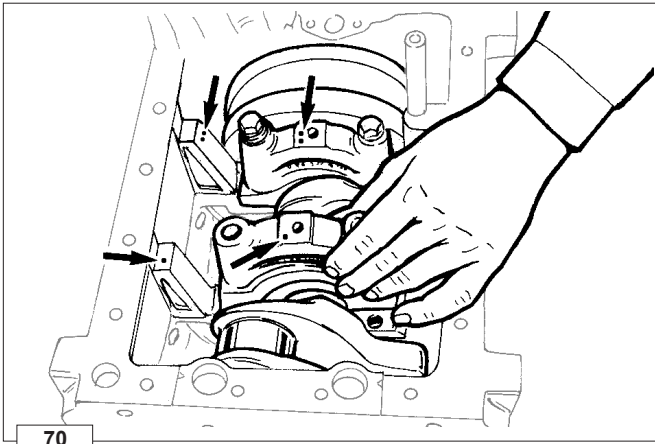

Center main bearings

The main bearing caps and the crankcase have reference holes marked on them (one, two or three).



Important

In the assembly stage make sure that the number of holes on the bearings matches those on the crankcase and that they are on the same side.

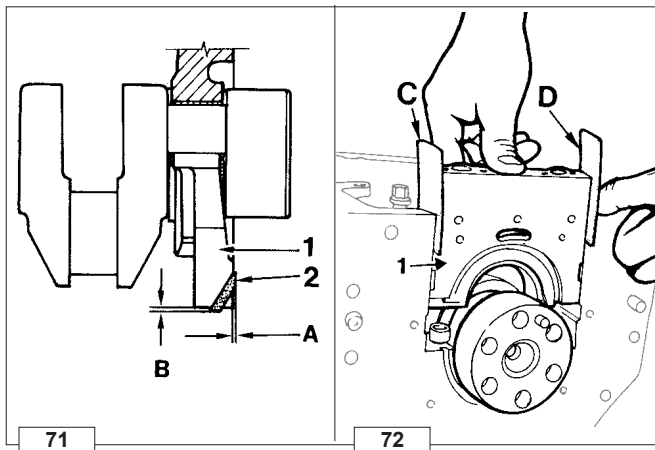

Main bearing caps timing side - flywheel side

When refitting rear flywheel side main bearing cap **1**, replace the rubber gaskets **2** considering that **A** and **B** should protrude 0.5÷1.0 mm from the crankcase; cut any excess portion.

Follow the same procedure for the timing side main bearing cap. To introduce the supports complete with silicone rubber seals **2** into the crankcase place two plates **C** and **D** measuring 0.1 mm in thickness between the surfaces.

- Tighten the screws to 120 Nm.

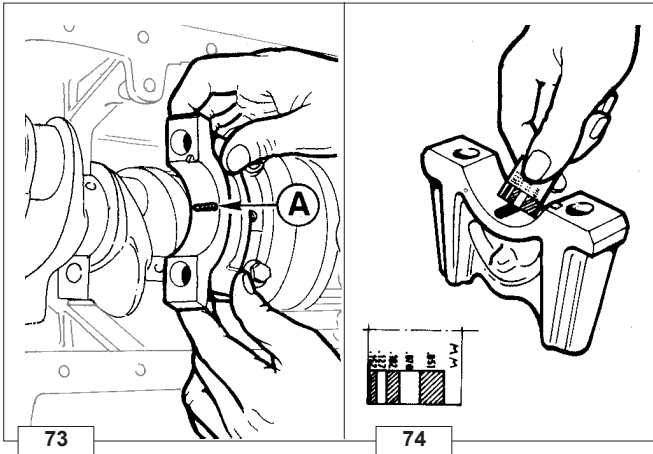

Check clearance between main bearings and journals

Use "Perfect Circle Plastigage" **A** and position it with a few drops of oil at the center of the half bearing.

○ Tighten bolts to 120 Nm.

Determine clearance by measuring the squeezed portion of the plastigage with the indexed scale supplied.

➤ For clearance between main journals, connecting rod big end journals and the corresponding bearings fig 79.

Important
 When replacing bearings make sure that the lower half is kept separate from the upper one.

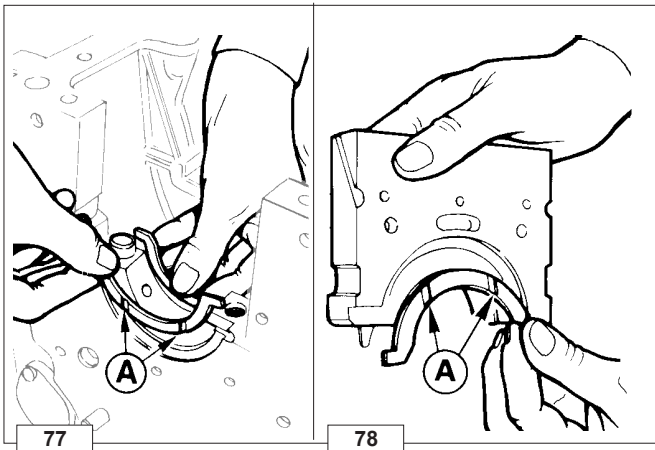

Grease the shoulder half-rings so that they will remain in their seats during assembly. Halves should be fitted with grooves **A** as shown in the figure 77-78. Thrust bearing thickness = 2.31÷2.36 mm; oversize halves with thickness increased by 0.1 and 0.2 mm are available as spares.

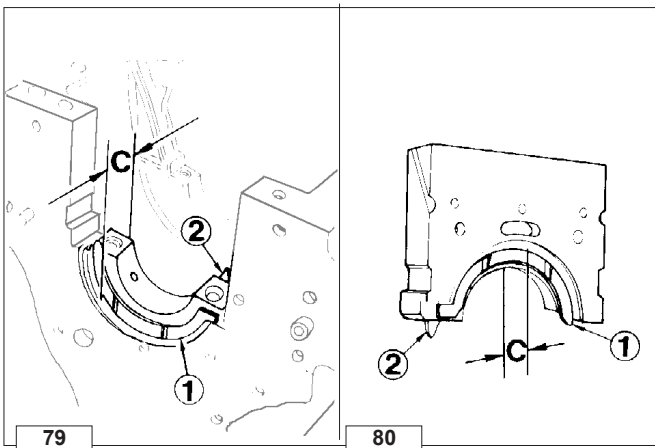

Thrust bearing, oversizes

Grinding **B** according to the above table, following half-rings can be assembled:

1st Oversize:

Half-rings **1** and **2**, on both the support sides +0.10 mm.

2nd Oversize:

Half-rings **1** and **2**, on one support side +0.10 mm and on the other side +0.20 mm.

3rd Oversize:

Half-rings **1** and **2**, on both the support sides +0.20 mm.

	C	B (fig. 82)	A (fig. 81)
STD	27,77 ÷ 27,92	28,00 ÷ 28,05	0,08 ÷ 0,28
1st Oversize	27,97 ÷ 28,12	28,20 ÷ 28,25	
2nd Oversize	28,07 ÷ 28,22	28,30 ÷ 28,35	
3rd Oversize	28,17 ÷ 28,32	28,40 ÷ 28,45	

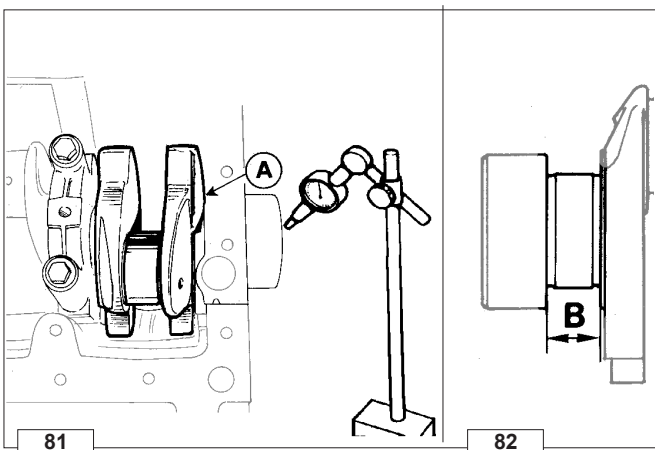

Crankshaft end play

After tightening main bearings measure the end play **A** between the crankshaft shoulder on the flywheel side and main bearing halves.

Rif.	Clearance (mm)
A	0,08 ÷ 0,28
B	28,00 ÷ 28,05

If the end play does not fall within the given values check **B** and possibly fit the oversize thrust bearings.

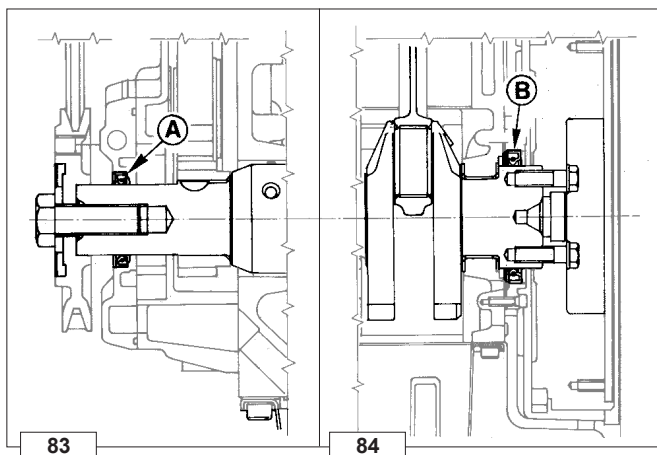

Crankshaft front and rear oil seal

The front oil seal **A** is located in the oil pump cover while the rear oil seal ring **B**, is positioned in the flange on the flywheel side.

Replace seals if warped, hardened or damaged.

In case of replacement:

- Carefully clean the seat.
- Soak the seal in engine oil for approximately half an hour.
- Fill the inside with grease and lubricate and sealing lip with thick oil.
- Drive the seal into its seat exerting a uniform pressure over the entire front area.

Warning: In case of room temperature below -35°C seals could become damaged.

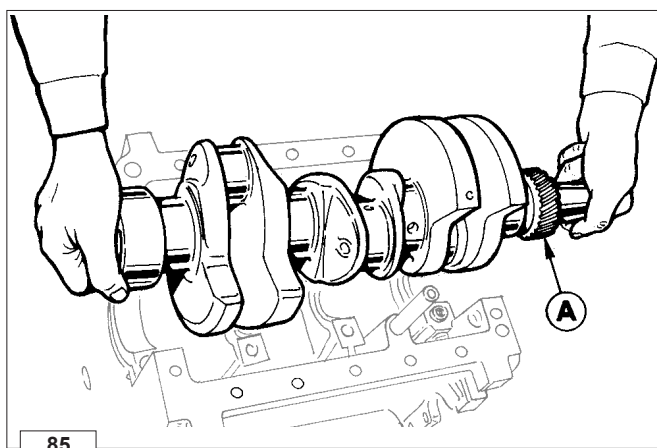

Crankshaft timing gear

If gear **A** has to be replaced, use a bearing puller to remove it. To reassemble it, you need to heat it up to a temperature of $180^{\circ} \div 200^{\circ}\text{C}$ and then fit it snugly.

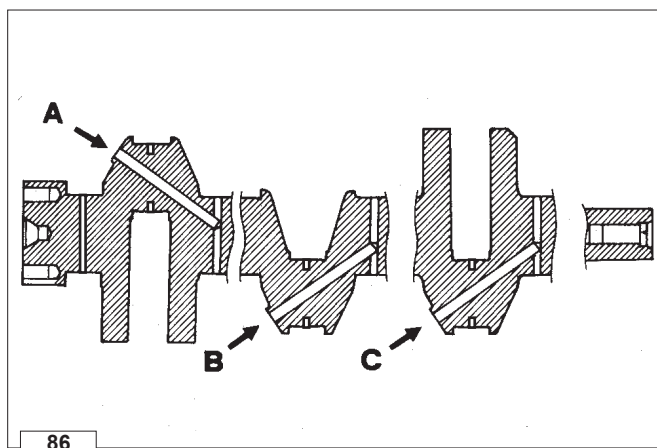

Crankshaft lubrication ducts



Important

During repair operations, when using compressed air, wear eye protection.

Dip crankshaft into a bath (use a cleaning product). Remove plugs and clean ducts **A**, **B** and **C** with a pointed tool. Finally blow with compressed air. Re-place plugs using a caulking tool and check for sealing.

Checking main journals and crank pins

Use an outside micrometer gauge.

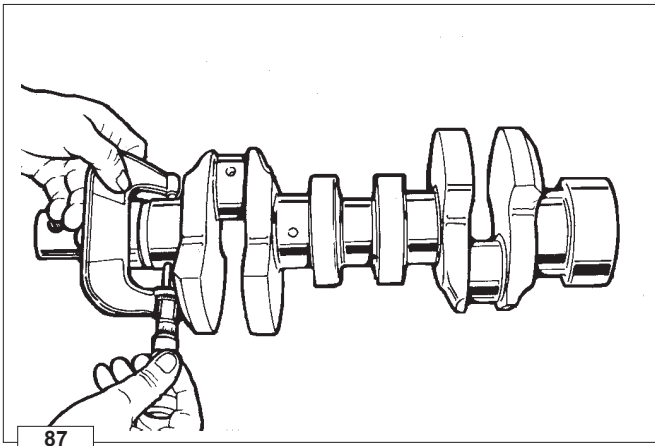

87

Main journal and connecting rod big end journal diameter

Rif.	KDW 1603-2204-2204/T Dimensions (mm)
A	59,981±60,000
B	49,984±50,000

The crankshaft is made of spheroidal graphite cast iron hardened at the level of the oil seal rings 1 and 2.
Hardness 55 hrc, hardening depth 0.5÷1.5 mm.

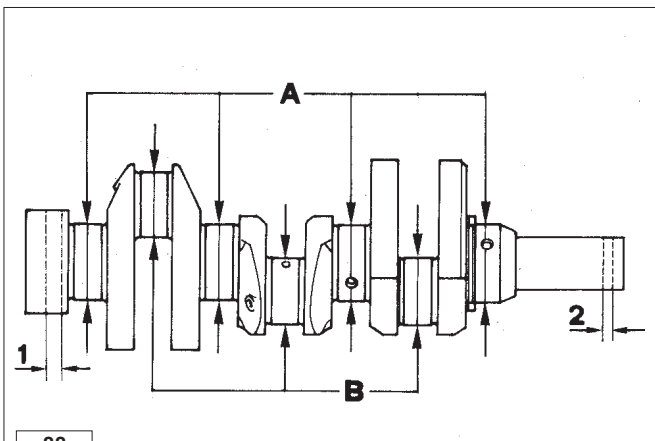

88

Main bearing and connecting rod big bearing inside diameter (mm)

➡ See fig. 73 and 74 for checking procedures.

Note: Both main bearing and connecting rod big end bearings are available with inside diameter measuring 0.25 and 0.50 mm.

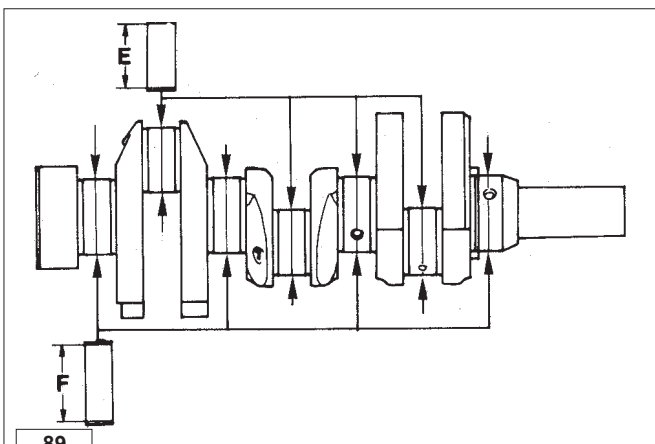

89

Rif.	KDW 1603-2204-2204/T Dimensions	
E	50,035±50,066	
F	59,04±59,969	
Rif:	Clearance	Limit value
E-B	0,035-0,077	0,150
F-A	0,031-0,096	0,200

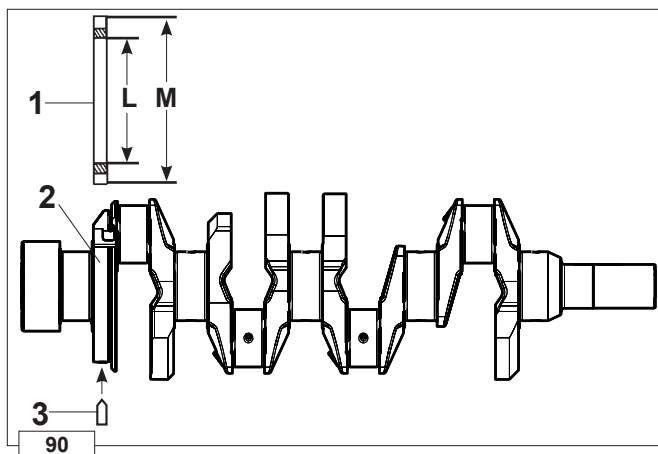

Crankshaft for engines with dynamic equalizer (only four-cylinder engines).

The crankshaft comes with seat for the control gear of the counter-rotating shaft dynamic balancer.
With centering hole (spring pin).

Components:

- 1 Control gear for counter-rotating shafts
- 2 Seat for the control gear of counter-rotating shafts
- 3 Dowel pin

Ref.	Dimensions (mm)
L	132,00 ÷ 132,03
M	132,07 ÷ 132,09

To replace the gear heat it up to 180°±200°C.

Locate it into its seat so that the timing reference marks on the teeth are found on the flywheel side.

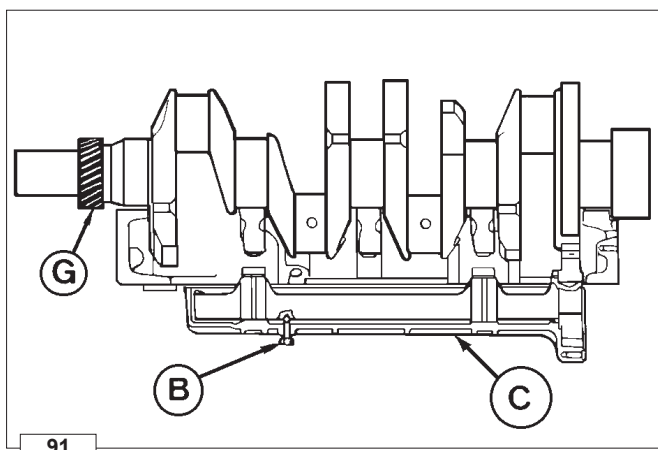

Dynamic balancer (on request) -

Adjustment of clearance between teeth D and ring gear A

Follow figures 91 and 92.

Screw the screw **B** into support **C** taking care to centre the hole in the mass of the gear **D** to lock it.

Fit the mass assembly under the crankcase so that the tooth with reference **E** goes between the teeth with references **F** of Control gear dynamic balancer.

Fix the mass assembly with the four M10 screws to the crankcase, provisionally tightening it to 40 Nm.

Don't remove screw **B**.

By making the driving shaft turn, check the clearance between the ring gear **A** and the gear of mass **D**; set a comparator with the feeler on one tooth of the timing system control gear **G**; by turning the driving shaft a little way check the clearance which must be 0.026÷0.067.

If the clearance measured does not come within the values given, repeat the operation placing the 0.05 mm shims provided for adjustment between the support **C** and the crankcase.

When mounting the balancer, lubricate the bushings with Molikote then couple the two masses, taking into account the references **H** and **I**.

Permanently fix the support **C** to the crankcase by tightening the screws to 50 Nm plus one turn of the wrench clockwise through 45°.

The four screws will have to be mounted with a few drops of Loctite 242.

Remove screw **B**.

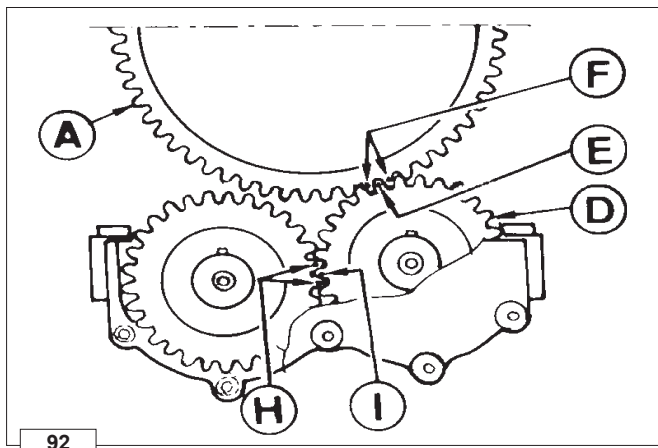

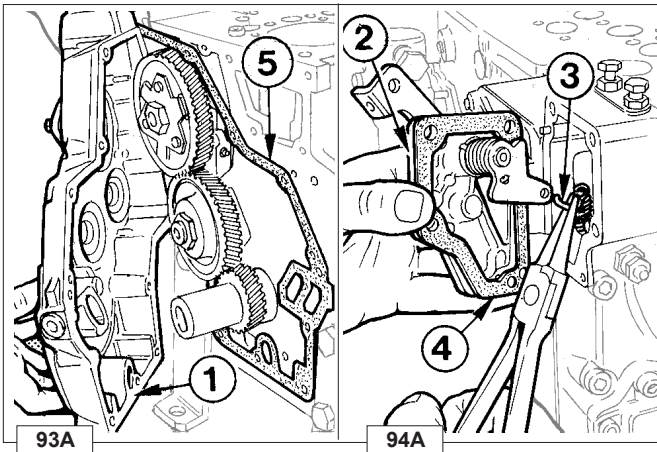

Front cover (before the serial number 7366305)

To remove front cover 1 bring the 1st cylinder to the top dead center.
Remove throttle cover 2 and release spring 3.
When refitting replace gasket 4 and 5.

- Tighten front cover 1 to 25 Nm.

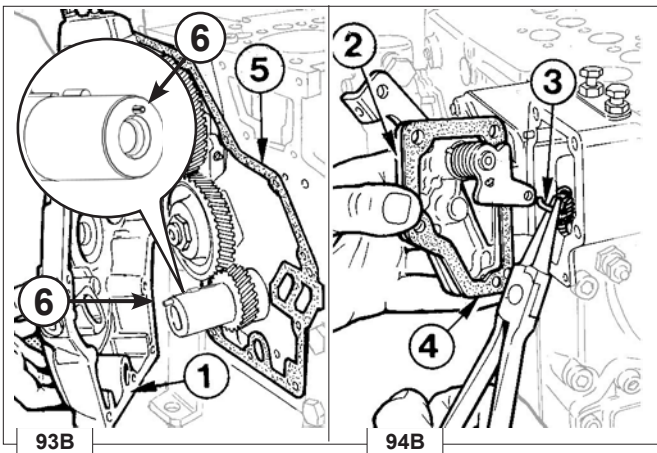

Front cover (after the serial number 7366306)

To disassemble the cover 1 rotate the crankshaft until the plug 6 of centering pulley command alternator is located in the upward position.

Remove throttle cover 2 and release spring 3.
When refitting replace gasket 4 and 5.

- Tighten front cover 1 to 25 Nm.

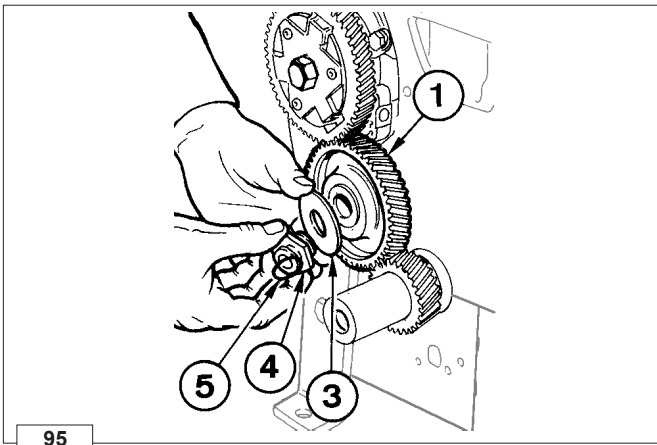

Idler gear and hub

Components:

- 1 Idle wheel
- 2 Hub
- 3 Thrust washer
- 4 Fitting
- 5 Oil seal ring
- 6 Bushing lubrication hole
- 7 Thrust washer

Note: Unscrew fitting 4 clockwise and when refitting it to 150 Nm.

Rif.	Dimensions (mm)	Play A - B (mm)	Worn limit A - B (mm)
A	36,000 ÷ 36,020	0,025 ÷ 0,061	0,120
B	35,959 ÷ 35,975		
		Axial play (mm)	Worn limit (mm)
C	1,950 ÷ 2,050	0,100 ÷ 0,300	0,600
D	0,960 ÷ 1,000		

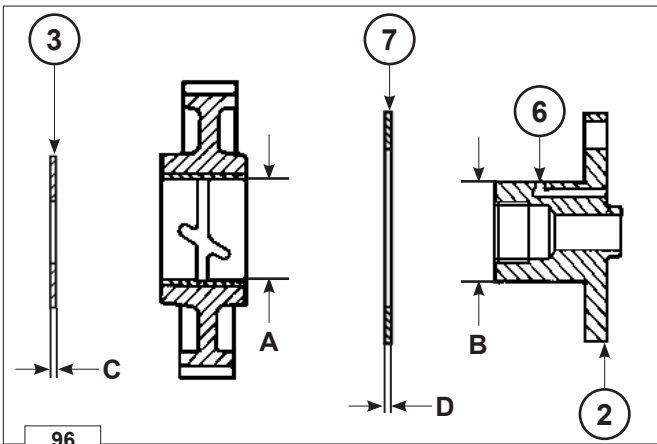

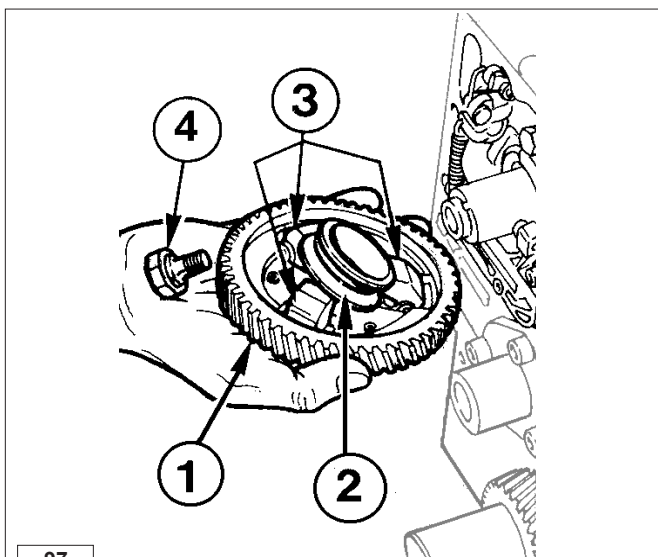

97

Speed governor

i Important

During reassembly, make sure the components are undamaged and verify they work properly. Malfunctioning of the speed governor can cause serious damage to the engine and to people in the vicinity of it.

Components:

- 1 Gear
- 2 Bell
- 3 Counterweights
- 4 Bolt
- 5 Throttle control rod
- 6 Governor spring
- 7 Injection pump delivery rod
- 8 Yoke 9 adjustment eccentric
- 9 Control yoke for injection pump delivery rod
- 10 Bushing
- 11 Lever
- 12 Adjusting screw.

Yoke 9 is pre-set through screw 12 and eccentric 8. Do not unscrew.

- When refitting camshaft gear 1 tighten bolt 4 to 100 Nm.

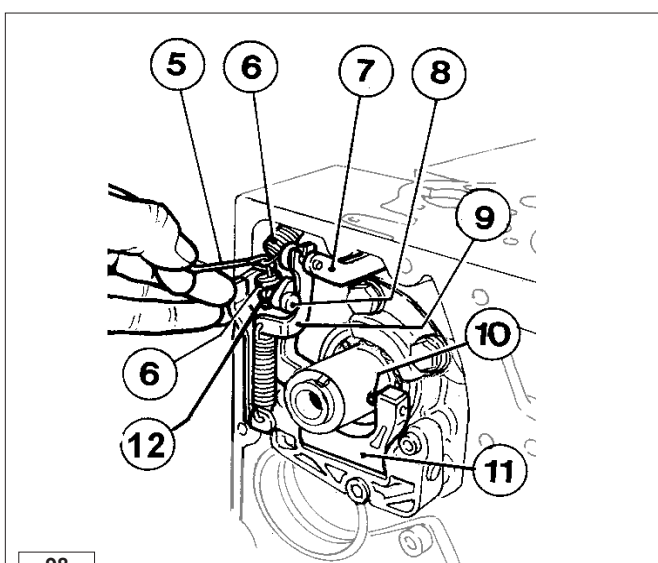

98

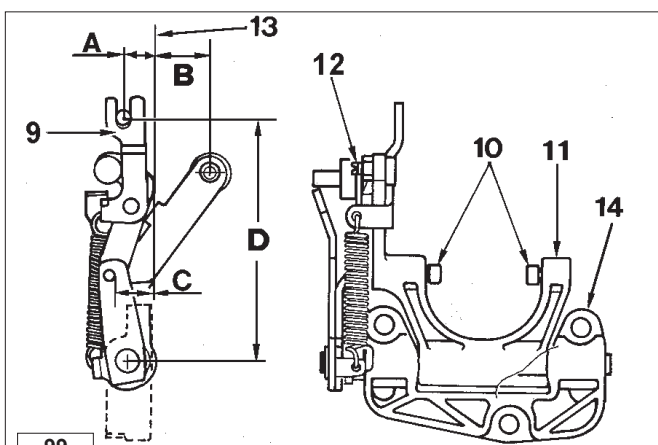

99

Dimensions for injection pump delivery control yoke adjustment

Components:

- 9 Control yoke for injection pump delivery rod
- 10 Bushing
- 11 Lever
- 12 Adjusting screw
- 13 Reference and mounting plane for support 14
- 14 Lever Support

Ref.	Dimensions (mm)
A	10,8 mm
C	13,4 mm
D	88 mm

Note: If, when adjusting, screw 12 is unintentionally loosened adjust yoke 9 considering the dimensions A, C and D. In case of replacement lever 11 is supplied complete with preset yoke 9.

Camshaft gear - Speed governor counter weights

Components:

- 1 Camshaft gear
- 2 Governor weights
- 3 Governor weight support
- 4 Governor weight pin

The governor weights **2** are housed inside the camshaft gear **1**. The weights **2** can be of two types: light or heavy, depending on the speed rate and the type of application. Heavy weights for engines set to run at low rpm (1500 - 1800 rpm and agricultural applications), light weights for engines set to run at high rpm (2200 - 3000 rpm).

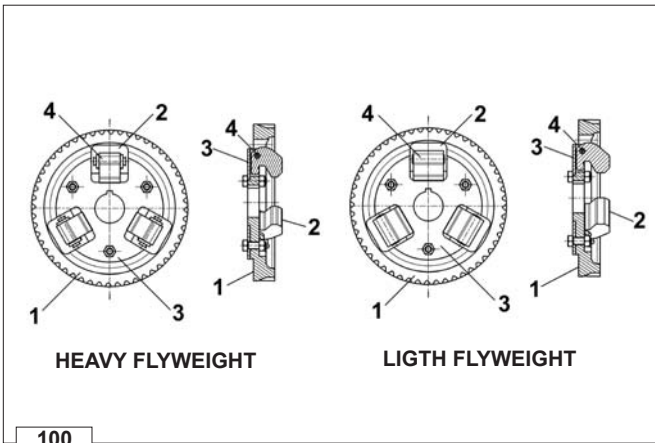

100

Speed governor counter springs

Besides the weights used according to the speed rate and application type, different types of springs with different features are used as well.

Components:

- 1 Camshaft gear
- 6 Speed governor springs

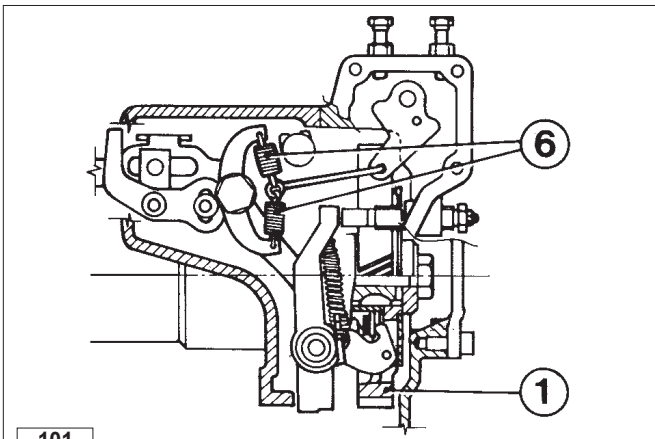

101

Components:

- 1 Limiting device / torque gearing device
- 2 Maximum rpm adjustment screw
- 3 Minimum rpm adjustment screw
- 4 Camshaft gear
- 5 Governor weight
- 6 Speed governor spring

For engines used on generating sets it is preferable to fit a single spring **6** to act against the heavy governor weights to avoid hunting with variations in the load and to achieve a more constant frequency over time.

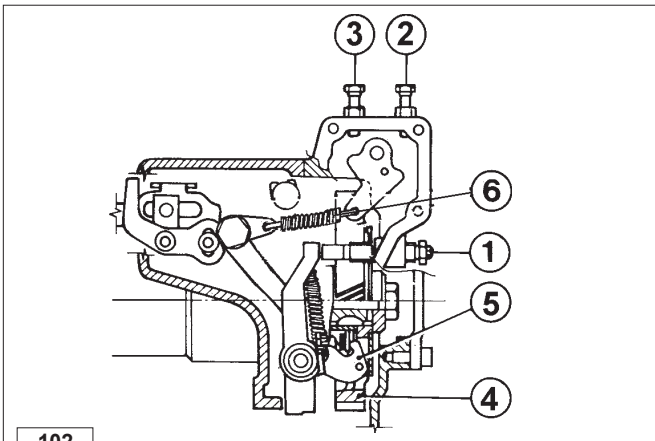

102

Frame with idling speed governor spring

Engines for applications requiring a certain power capacity at low speeds are fitted with the frame **2** complete with the idling speed spring which allows satisfying the above described requirements without the engine tending to stop.

Components:

- 1 Rocker arm with speed governor springs.
- 2 Frame for idling speed spring

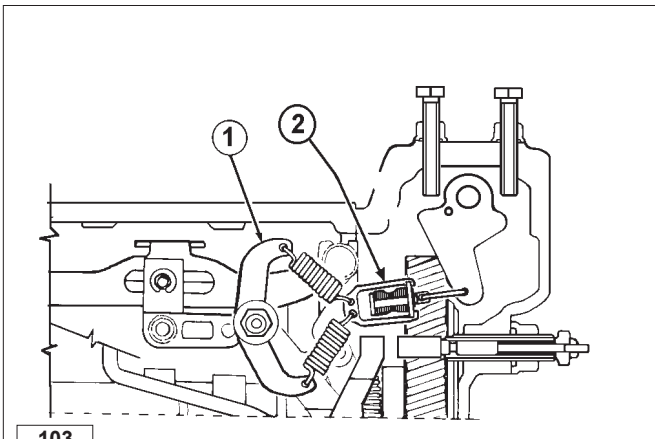

103

Summary tables of the governor equipment according to the speed variation.

KDW 1603			
rpm	Weight type	N.Spring	Spring serial number
1500	Duty	1	5655370
1500	Duty	2	5655154/5655156**
1800	Duty	1	5655369
1800	Duty	2	5655154**
2000	Light	2	5655135
2200-2900	Light	2	5655135
2800	Duty	2	5655405
3000	Light	2	5655129/5655135

KDW 2204_2204/T			
rpm	Weight type	N.Spring	Spring serial number
1500	Duty	1	5655370
1500	Duty	2	5655154/5655156*
1800	Duty	1	5655369
1800	Duty	2	5655154**
2000	Light	2	5655135
2200	Light	2	5655129/5655135
2500	Duty	2	5655129*
2800	Duty	2	5655405
3000	Light	2	5655129/5655135

* Idle frame
** Anti-hunting

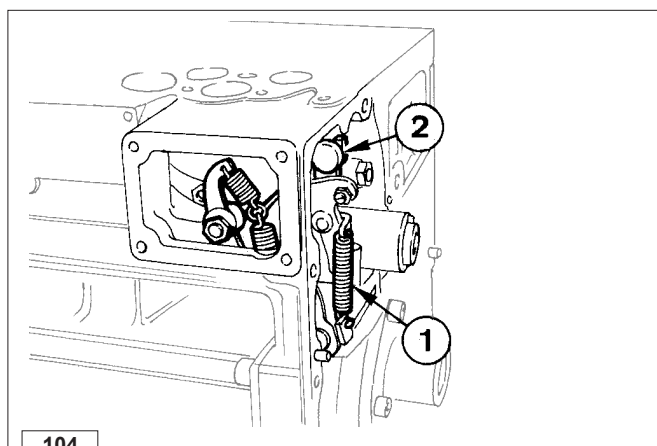

Spring for extra fuel supply at starting

The device is operated automatically: when the engine is stopped spring 1 acts on the injection pump control lever 2 providing maximum fuel delivery until the governor starts operating.

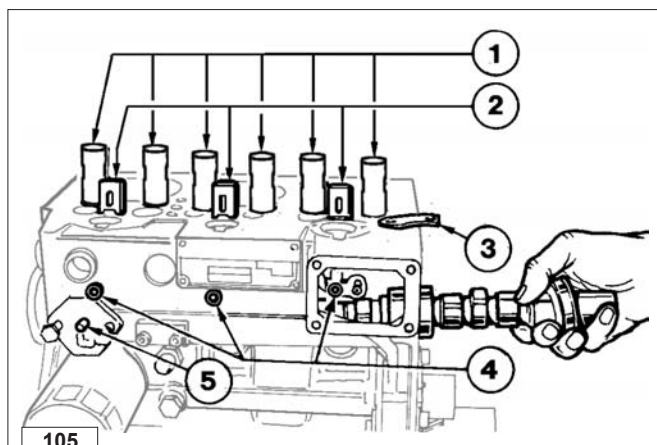

CAMSHAFT

Camshaft removal

To remove camshaft first remove valve tappets 1, injection pump follower 2, bearing stop plate 3 and fuel pump control rod 5.

Note: To remove follower 2 loosen screw 4 by three or four turns.

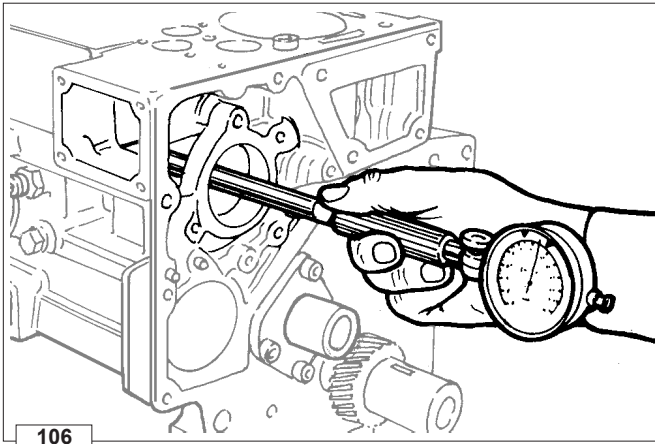

106

Checking camshaft bushing internal diameter

Use a bore gauge.
If the diameter size does not correspond to the given value remove the bushings using the special tool (pic. 109 and 110) and replace.

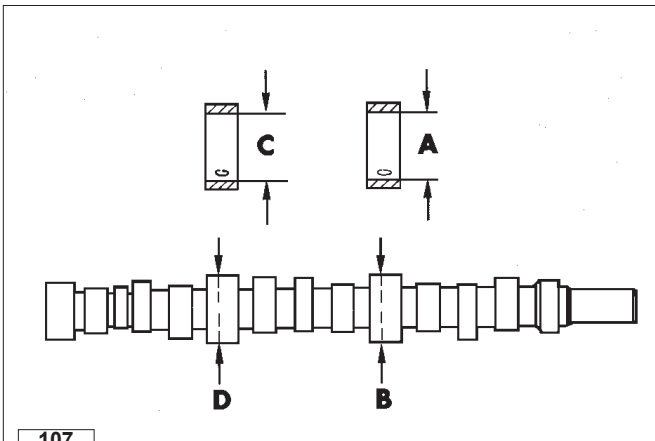

107

Camshaft journals and bushings in model KDW 1603

Rif.	Dimensions (mm)	Clearance (mm) (A-B) (C-D)	Worn limit (mm) (A-B) (C-D)
A	43,000 ÷ 43,025	0,040 ÷ 0,085	0,16
B	42,940 ÷ 42,960		
C	42,000 ÷ 42,025		
D	41,940 ÷ 41,960		

Note: A and C values refer to driven in and bored bushings.

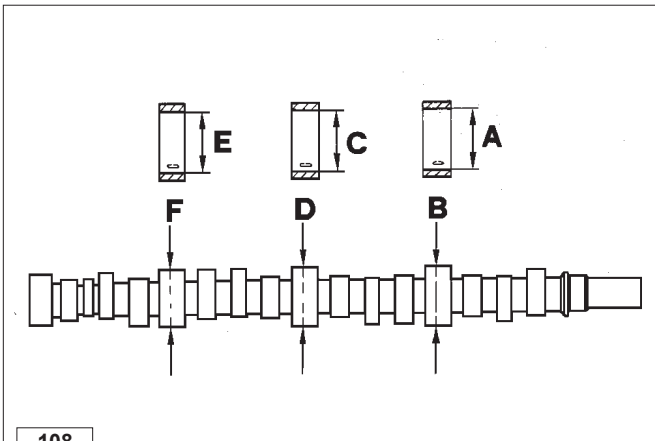

108

Camshaft journals and bushings in models KDW 2204-2204/T

Rif.	Dimensions (mm)	Clearance (mm) (A-B) (C-D) (E-F)	Worn limit (mm) (A-B) (C-D) (E-F)
A	44,000 ÷ 44,025	0,040 ÷ 0,085	0,16
B	43,940 ÷ 43,960		
C	43,000 ÷ 43,025		
D	42,940 ÷ 42,960		
E	42,000 ÷ 42,025		
F	41,940 ÷ 41,960		

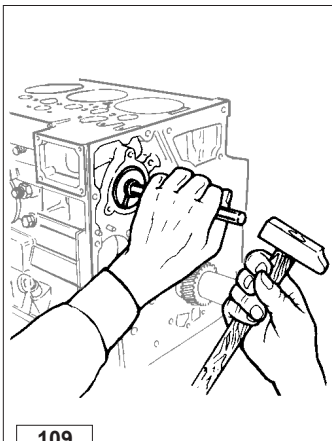

109

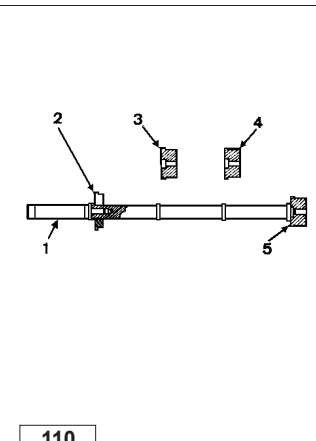

110

Camshaft bushing replacement

Tool part No.7104-1460-021

Components:

- 1 Mandrel
- 2 Centering bushing
- 3 Bushing diam. 44 mm
- 4 Bushing diam. 43 mm
- 5 Bushing diam. 42 mm



Important

Before driving in the bushing, position it in such a way that the lubricating hole matches with the hole in the crankcase.

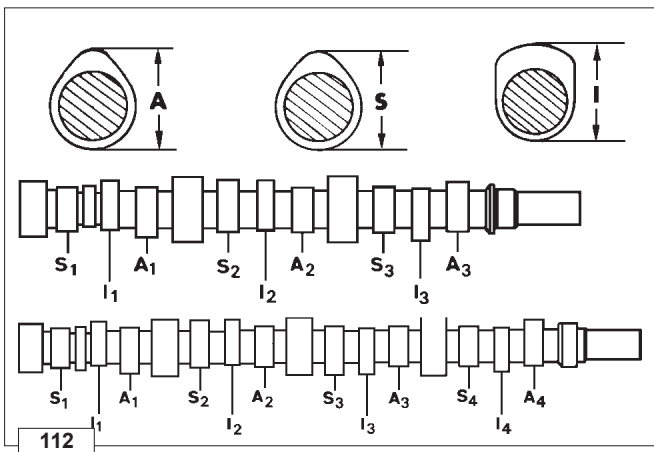

Intake, exhaust and injection cam height for engine with hydraulic tappets

A (mm)	S (mm)	I (mm)
35,44 ÷ 35,50	35,14 ÷ 35,20	33,95 ÷ 34,00

A1 = 1st cyl. intake cam
A2 = 2nd cyl intake cam
A3 = 3rd cyl intake cam
A4 = 4th cyl intake cam

S1 = 1st cyl. exhaust cam
S2 = 2nd cyl exhaust cam
S3 = 3rd cyl exhaust cam
S4 = 4th cyl exhaust cam

I1 = 1st cyl. injection cam
I2 = 2nd cyl injection cam
I3 = 3rd cyl injection cam
I4 = 4th cyl injection cam

Camshaft timing

Fit idler gear **B** by making timing mark **2** coincide with timing mark **1** on the camshaft control gear **A** and mark **3** with **4** on the timing gear **C**.

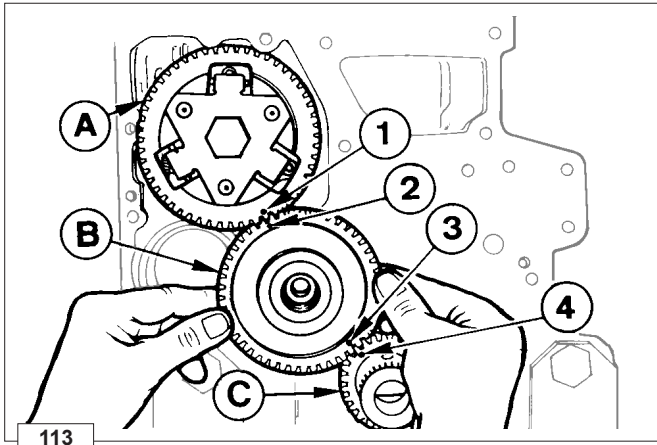

113

Valve timing without considering timing marks

Locate piston **1** (on flywheel) at the top dead center. Position two small rods **A** of the same length onto the tappets. Rotate camshaft stopping when cylinder **1** tappets are in overlap position (intake open exhaust closed). Using the straight edge **B** check that rods **A** are at the same length. Mark the idler gear with camshaft and timing gear.

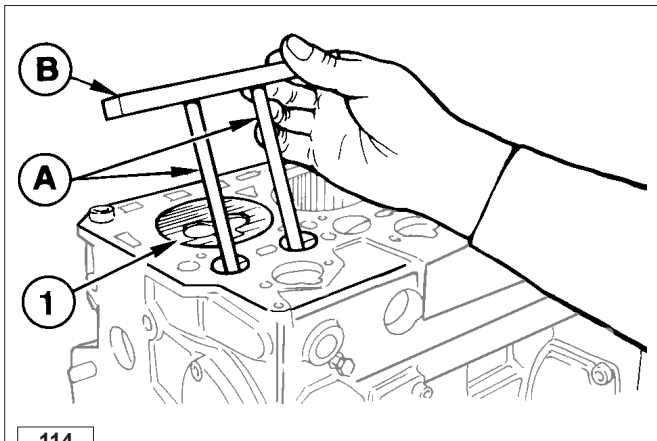

114

Valve timing check

Check valve timing at the crankshaft. The values shown are checked at the flywheel circumference (with flywheel diameter of 290 each degree corresponds to 2.53 mm). Set valve clearance at 0.65-0.70 mm (after checking reset the value to 0.15 mm). Set dial gauge on intake valve to a zero value; by rotating the crankshaft according to its direction of rotation you can measure α (intake valve opening advance referred to top dead center **S**) and β (intake valve closing delay referred to bottom dead center **I**). Follow the same procedure for exhaust valves checking γ (exhaust valve opening advance) and δ (exhaust valve closing delay).

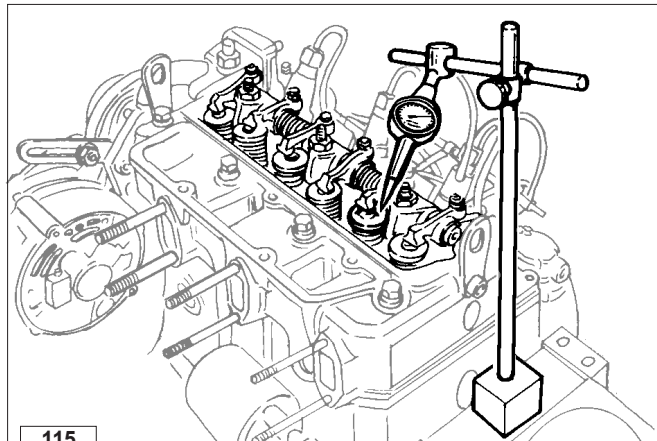

115

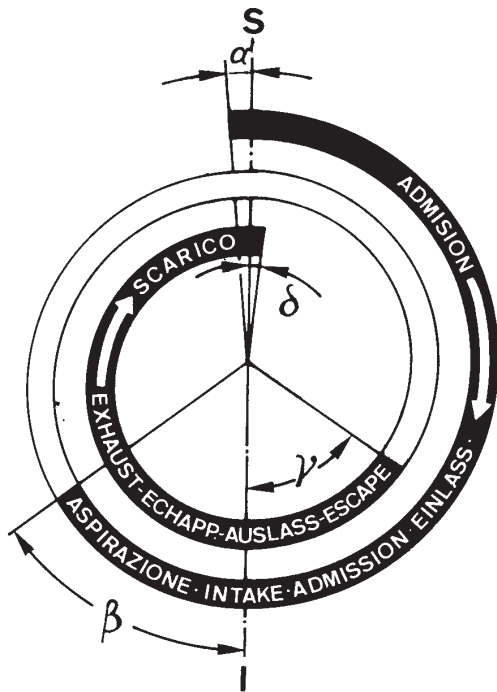

Legend

- S** = piston at top dead centre
- I** = piston at bottom dead centre
- α = intake valve open
- β = intake valve closed
- γ = exhaust valve open
- δ = exhaust valve closed

116

Engines with hydraulic tappets

Timing belt operating angles (with valve clearance set to zero)

r.p.m.	Engine type	Intake	Exhaust
under 2400 r.p.m.	1603_2204	$\alpha = 8^\circ$ before S $\beta = 28^\circ$ after I	$\gamma = 36^\circ$ before I $\delta = 8^\circ$ after S
upper 2400 r.p.m.	1603_2204	$\alpha = 12^\circ$ before S $\beta = 36^\circ$ after I	$\gamma = 48^\circ$ before I $\delta = 12^\circ$ after S
under/upper 2400 r.p.m.	2204/T	$\alpha = 12^\circ$ before S $\beta = 48^\circ$ after I	$\gamma = 58^\circ$ before I $\delta = 14^\circ$ after S

Camshaft end play

Check camshaft end play after removing the cylinder head, the injection and the fuel pumps from the engine.
 Check that plate 1 is tightened.
 Position the dial gauge on the camshaft front surface; push and pull the camshaft.
 Maximum end play should be 0,008 mm (ball bearing end play).

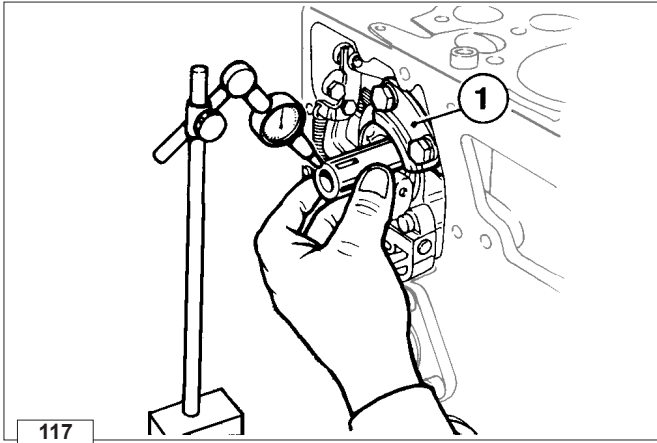

117

Hydraulic pump p.t.o.

A = 3rd p.t.o. with hydraulic pump Gr 2.
B = 4th p.t.o. with hydraulic pump Gr 1

Hydraulic pumps of either GR 1 or GR 2 type can be fitted, even simultaneously, on the 3rd and 4th p.t.o. provided the resulting torque does not exceed 40 Nm.
 The gear ratio between engine r.p.m. and 3rd and 4th p.t.o. is 1:1.

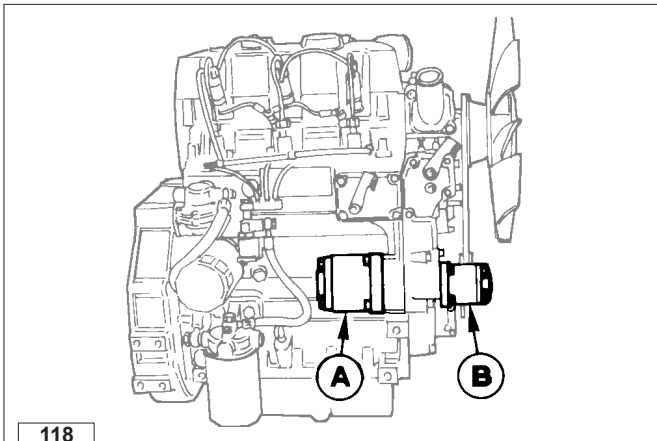

118

GR 1 and GR 2 hydraulic pump 3rd p.t.o.

- 1 O-R
- 2 O-R
- 3 Center ring
- 4 Circlip
- 5 Thrust washer
- 6 GR 2 hydraulic pump flange
- 7 GR 1 hydraulic pump flange
- 8 Bushing
- 9 Thrust washer
- 10 GR 2 hydraulic pump drive gear
- 11 GR 1 hydraulic pump drive gear
- 12 Control gear

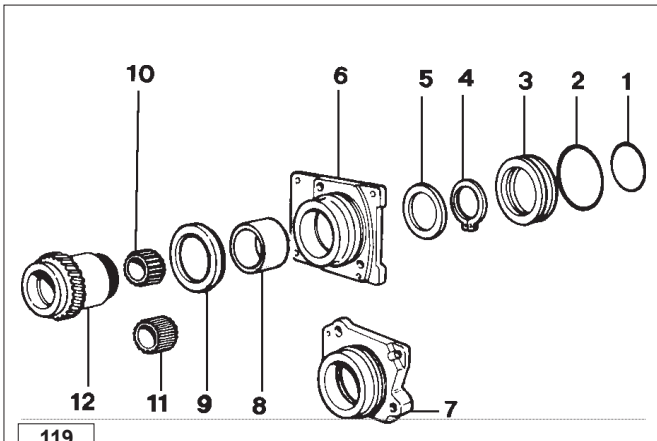

119

Turbocharger

It is installed on the engine in two versions: with air intake on the flywheel side and with air intake on the fan side.

To control the supercharge air pressure, screw the pressure gauge into the M8 holes **A** and **B** both for the version with air intake on flywheel side (fig. 120) and for air intake on fan side (fig.121).

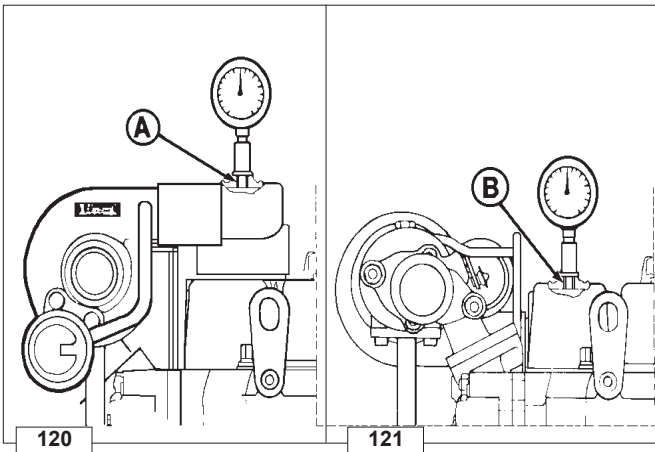

Turbocharger components

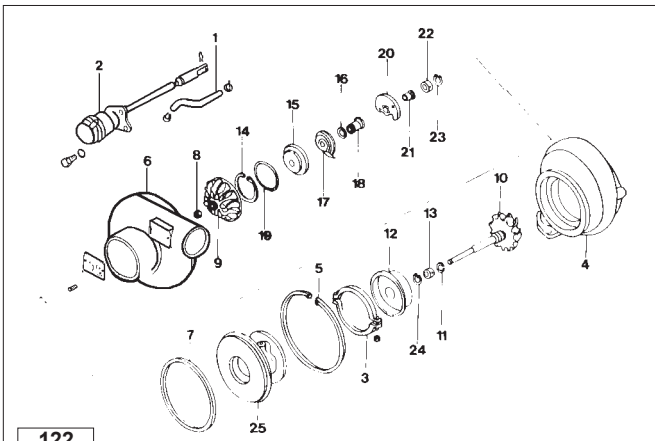

- 1 Flexible hose
- 2 Actuator
- 3 Collar
- 4 Turbine body
- 5 Snap ring
- 6 Compressor volute
- 7 Thickness
- 8 Nut
- 9 Lock nut
- 10 Shaft with turbine
- 11 Segment
- 12 Flame shield
- 13 Bearing
- 14 Snap ring
- 15 Thickness
- 16 Segment
- 17 Oil deflector
- 18 Thrust block sleeve
- 19 O-ring
- 20 Thrust block bearing
- 21 Thrust block ring
- 22 Bearing
- 23 Snap ring
- 24 Snap ring
- 25 Bearing support

Turbocharger Testing

Get a pressure gauge with scale from zero to 2 bar, connect it according to fig. 120 and 121.

Start up the engine, warm it up for a few minutes, then take it to 3000 rpm at the power NB.

The supercharge air pressure value to be measured is 89±93 KPa (0.89±0.93 bar).

If the setting pressure does not come within the required value it is necessary to adjust the stroke of the valve control rod **C** (Waste gate).

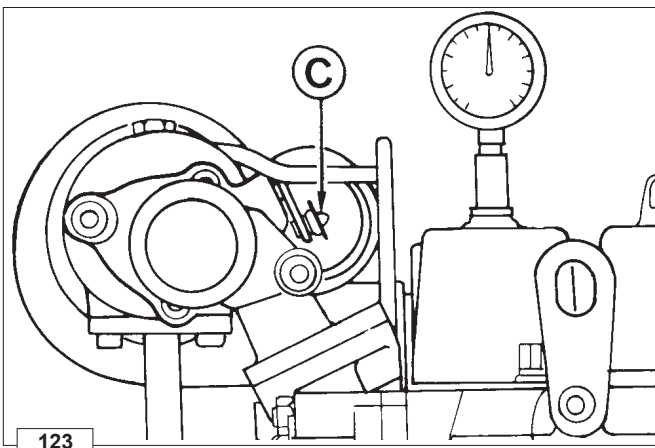

**Danger – Attention**

The engine may be damaged if operated with insufficient lube oil. It is also dangerous to supply too much lube oil to the engine because a sudden increase in engine rpm could be caused by its combustion.

Use proper lube oil preserve your engine. Good quality or poor quality of the lubricating oil has an affect on engine performance and life.

If inferior oil is used, or if your engine oil is not changed regularly, the risk of piston seizure, piston ring sticking, and accelerated wear of the cylinder liner, bearing and other moving components increases significantly.

Always use oil with the right viscosity for the ambient temperature in which your engine is being operated. Use the chart when chosing your engine oil.

**Danger – Attention**

The used engine oil can cause skin-cancer if kept frequently in contact for prolonged periods.

If contact with oil cannot be avoided, wash carefully your hands with water and soap as soon as possible.

Do not disperse the oil in the ambient, as it has a high pollution power.

LUBRICATION SYSTEM LAYOUT

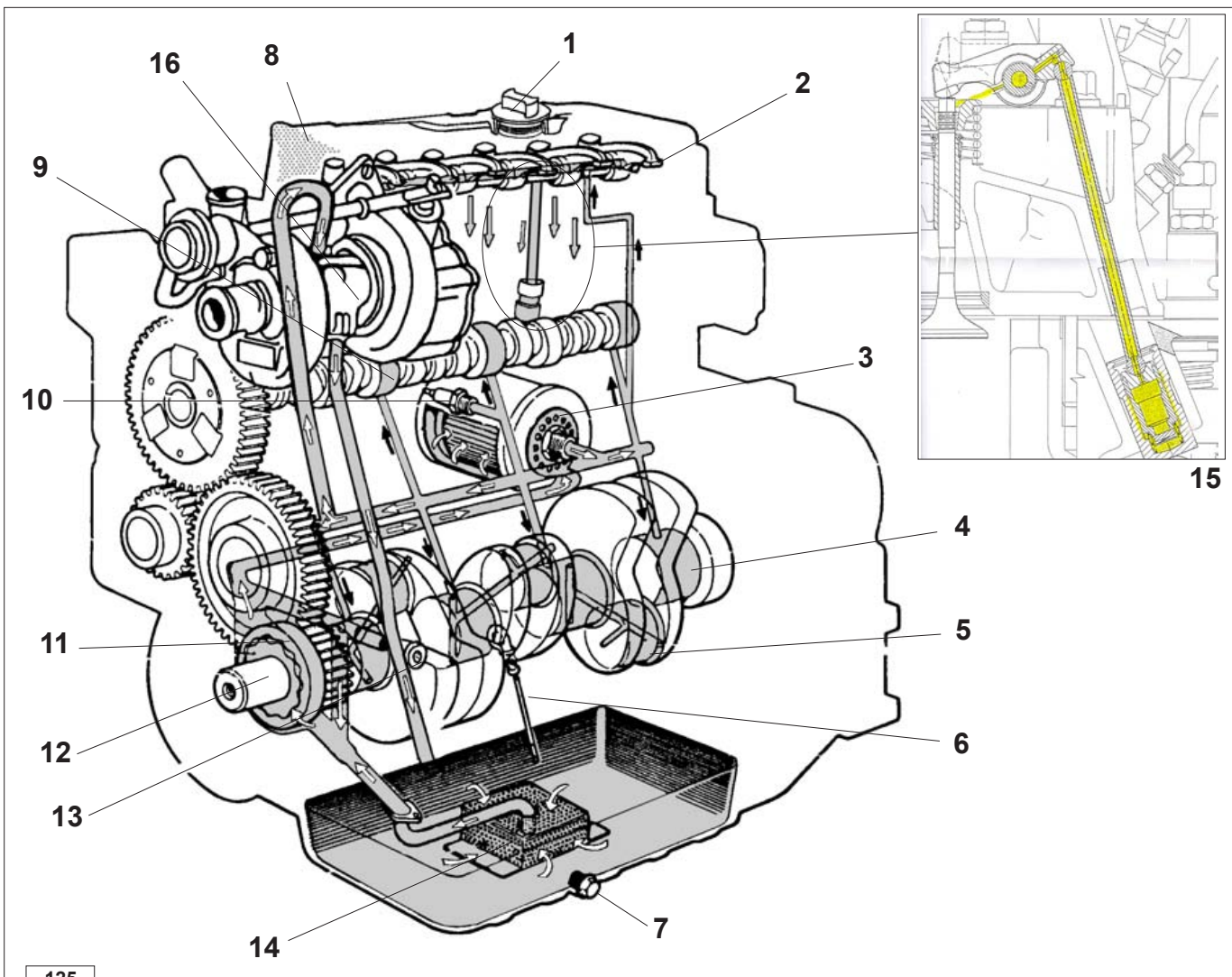
**Components:**

- | | | |
|---------------------------|-------------------------|----------------------------------|
| 1) Oil fill cap | 6) Oil dipstick | 11) Oil pump |
| 2) Rocker arm shaft | 7) Drain plug | 12) Crankshaft |
| 3) Oil filter | 8) Breather | 13) Oil pressure adjusting valve |
| 4) Main journal | 9) Camshaft | 14) Oil pick-up screen |
| 5) Connecting rod journal | 10) Oil pressure switch | 15) Hydraulic tappet |
| | | 16) Turbocharger (KDW 2204/T) |

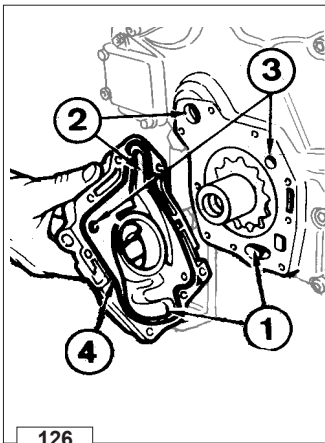

126

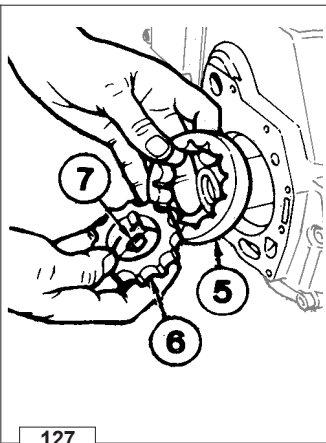

127

Oil pump

Components:

- | | |
|-------------------------------------|------------------|
| 1 Suction port | 5 External rotor |
| 2 Delivery port | 6 Internal rotor |
| 3 Oil pressure adjusting Valve port | 7 Key |
| 4 Gasket | |

The oil pump is driven by the crankshaft via key 7. Rotor 6 is locked in the circumferential but not in the axial direction. This allows the shaft to move axially while rotors 5 and 6 are prevented from damaging the pump sealing surfaces. Oil pump capacity = 24.5 litres/min. at a pressure of 4.5÷4.75 bar (engine speed 3000 rpm, oil temperature 38÷42°C).

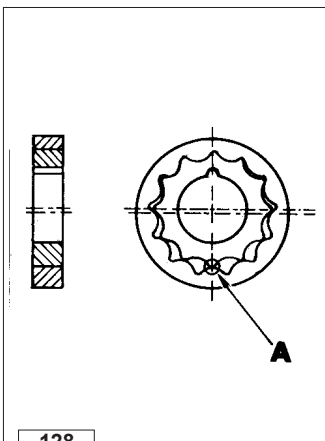

128

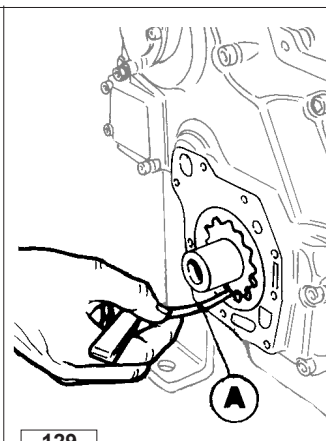

129

Oil pump rotor clearance

Measure clearance A between the teeth located along the axis of the keyway as shown in the figure 129; its value is 0.150 mm; worn limit clearance 0.280 mm.

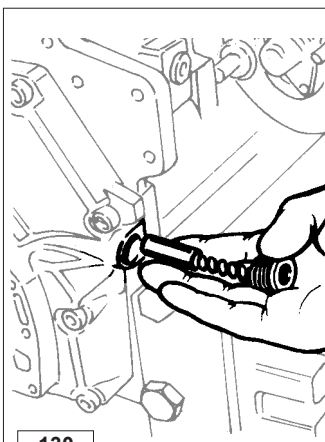

130

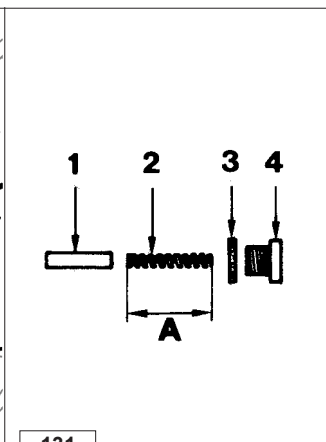

131

Oil pressure adjusting valve

Components:

- 1 Valve
- 2 Spring
- 3 Gasket
- 4 Plug

Length of spring A = 45.5 ÷ 46.0 mm.

Blow compressed air into the valve seat and carefully clean all components; using a caliper measure the length of spring A.

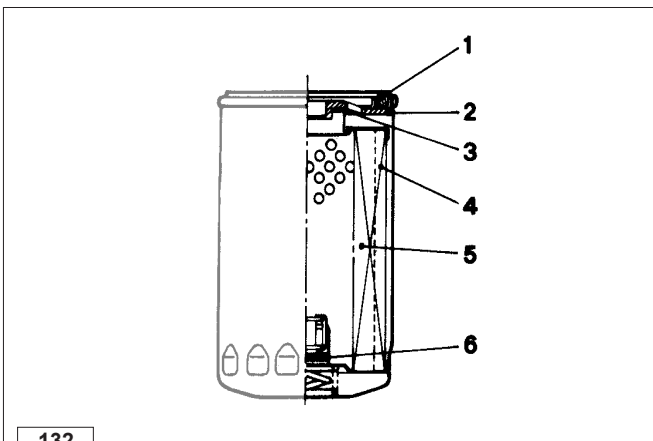

132

Oil filter cartridge

Components:

- | | |
|----------|----------------------|
| 1 Gasket | 4 Blade |
| 2 Plate | 5 Filtering material |
| 3 Gasket | 6 By-pass valve |

Specifications:

- Max. working pressure 7 bar
- Max. explosion pressure..... 20 bar
- Low temperature limit -35°C
- By-pass valve setting..... 2.1/2.8 bar
- Total filtering surface..... 2000 cm²
- Degree of filtration 15 µm

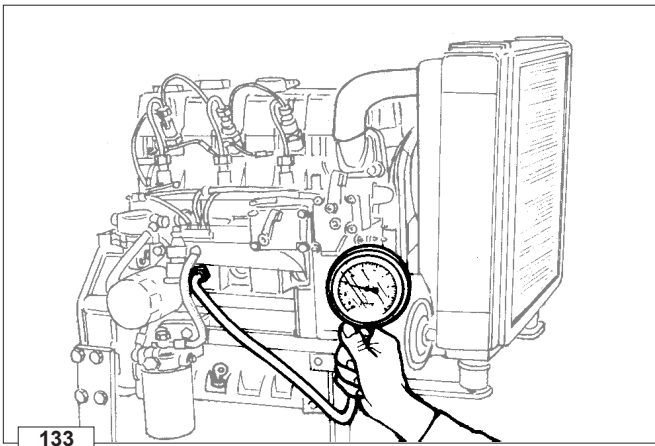

133

Oil pressure check

On completing assembly, fill with engine oil and fuel; connect a 10 bar pressure gauge to the pressure switch fitting. Start the engine and check pressure as a function of the oil temperature.

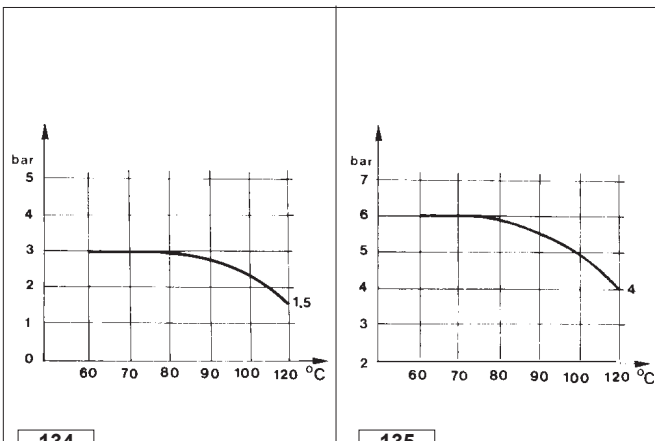

134

135

Oil pressure curve for KDW 1603

Fig. 134 - The curve is obtained at the oil filter level constant engine speed of 850 rpm in no-load conditions.

Fig. 135 - The curve is obtained at the oil filter level with engine working at 3000 rpm at the N power.

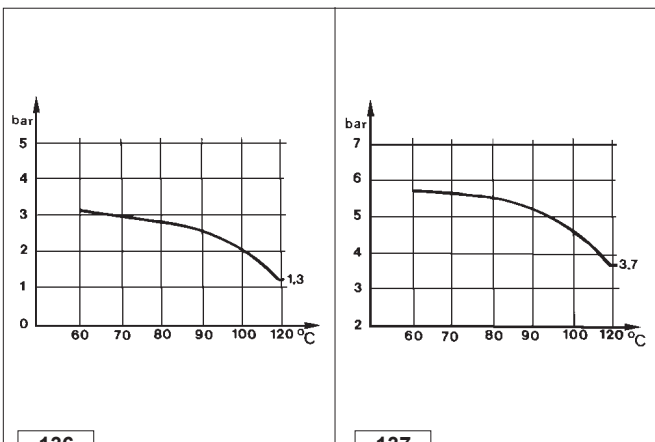

136

137

Oil pressure curve for KDW 2204

Fig. 136 - The curve is obtained at the oil filter level constant engine speed of 850 rpm in no-load conditions.

Fig. 137 - The curve is obtained at the oil filter level with engine working at 3000 rpm at the N power.

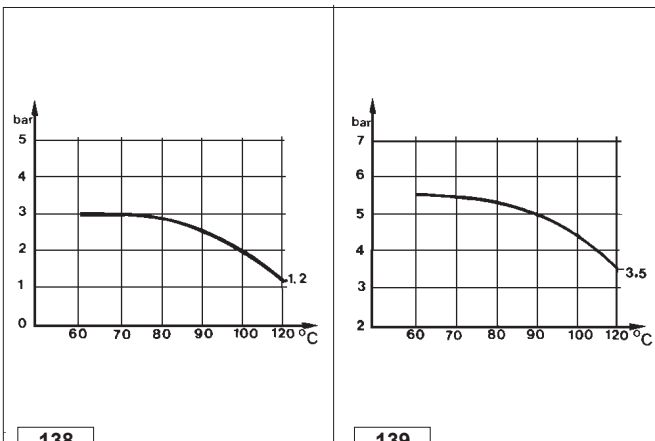

138

139

Oil pressure curve for KDW 2204/T

Fig. 138 - The curve is obtained at the oil filter level constant engine speed of 850 rpm in no-load conditions.

Fig. 139 - The curve is obtained at the oil filter level with engine working at 3000 rpm at the N power.

Note: The max lubrication oil temperature must be lower than the sum: ambient temperature + 95°C.

**Danger – Attention**

- The fluid coolant circuit is pressurized.
- Inspections must only be made when the engine has cooled and even in this case, the radiator or expansion chamber plug must be unscrewed with the utmost caution.
- If an electric fan is installed, do not approach a hot engine since the fan itself could start up even when the engine is at a standstill.
- Coolant fluid is polluting, it must therefore be disposed of in the correct way. Do not litter.

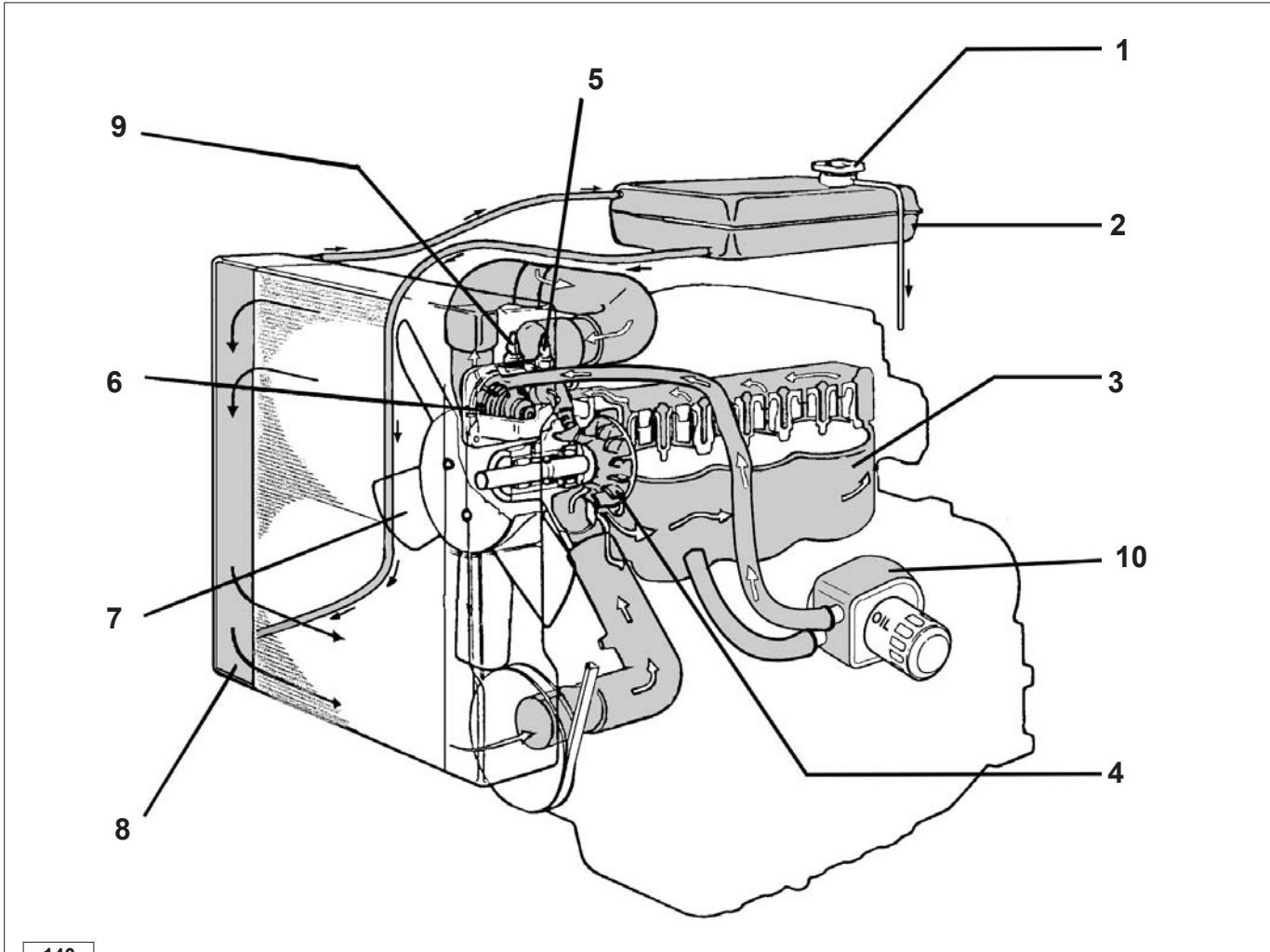
COOLING SYSTEM LAYOUT

140

Components:

- | | |
|-------------------------------------|---------------------------------|
| 1) Coolant fill cap | 6) Thermostat |
| 2) Expansion tank | 7) Fan |
| 3) Cylinder block | 8) Radiator |
| 4) Circulating pump | 9) Temperature sensor |
| 5) Coolant temperature warning lamp | 10) Heat exchanger (KDW 2204T). |

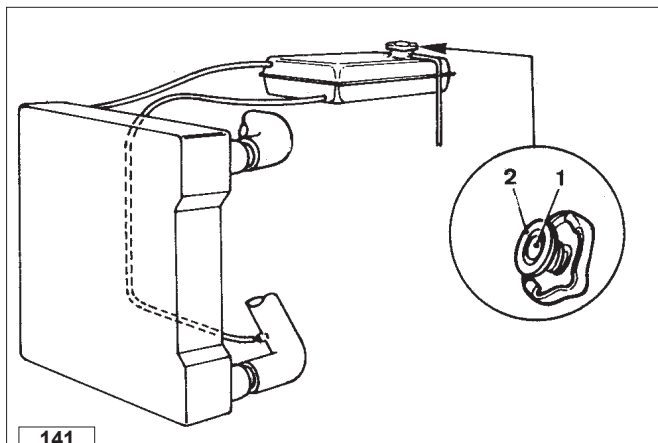

141

Expansion tank and cap

The expansion tank is separated from the radiator and is fitted with a coolant fill cap. The cap comes with vacuum valve 1 and pressure relief valve 2. The pressure relief valve opens at a pressure of 0.7 bar.

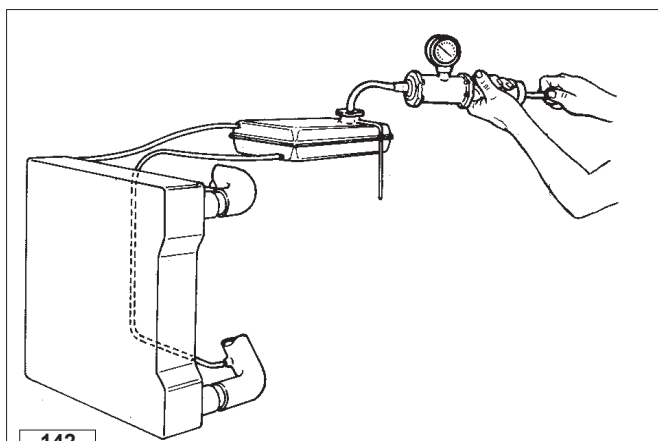

142

Checking for cooling system leaks

Remove the cap from the expansion tank and check coolant level. Replace the cap with one fitted with portable hand air pump coupling as shown in the figure 142. Compress air at a pressure of 1 bar for approximately 2 minutes. Check that no leaks occur.



Caution – Warning

In very dusty working conditions verify and clean the outside of the radiator frequently.

➡ Replace coolant as specified on page 22.

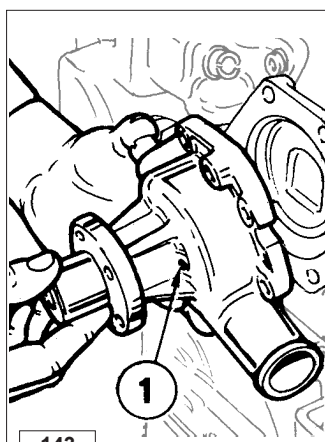

143

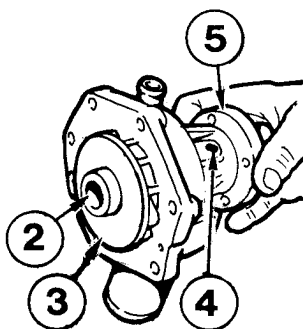

144

Coolant circulating pump

Impeller 3 and hub 5 are fitted to the shaft by press fit. To remove the impeller, screw the M 18x1.5 bolt into bore 2. To remove that shaft take 4 which locks the bearing to the pump body. A seal is located on the shaft between the bearing and the impeller. In case of worn-out seal, coolant leaks from hole 1.

KDW 1603 - 2204:

The ratio between the pump and engine rpm = 1:1.2
Pump delivery at 3000 rpm is 70 liters/min.

KDW 2204/T:

The ratio between the pump and engine rpm = 1:1.5
Pump delivery at 3000 rpm is 116 liters/min.

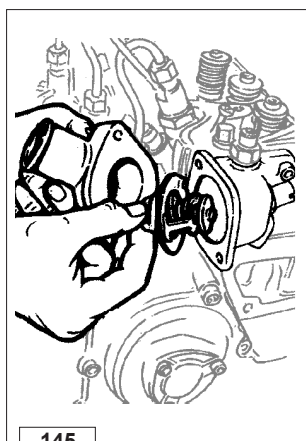

145

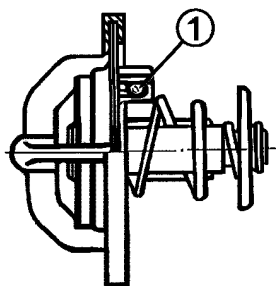

146

Thermostat

1 - Air valve

Specifications:

Opening temperature: 77°/81°C

Max. stroke at 94°C = 7.5 mm

Coolant flow rate with thermostat and valve in closed position = 15 Liters/h.



Danger – Attention

To avoid explosions or fire outbreaks, do not smoke or use naked flames during the operations.

Fuel vapours are highly toxic. Only carry out the operations outdoors or in a well ventilated place.

Keep your face well away from the plug to prevent harmful vapours from being inhaled. Dispose of fuel in the correct way and do not litter as it is highly polluting.

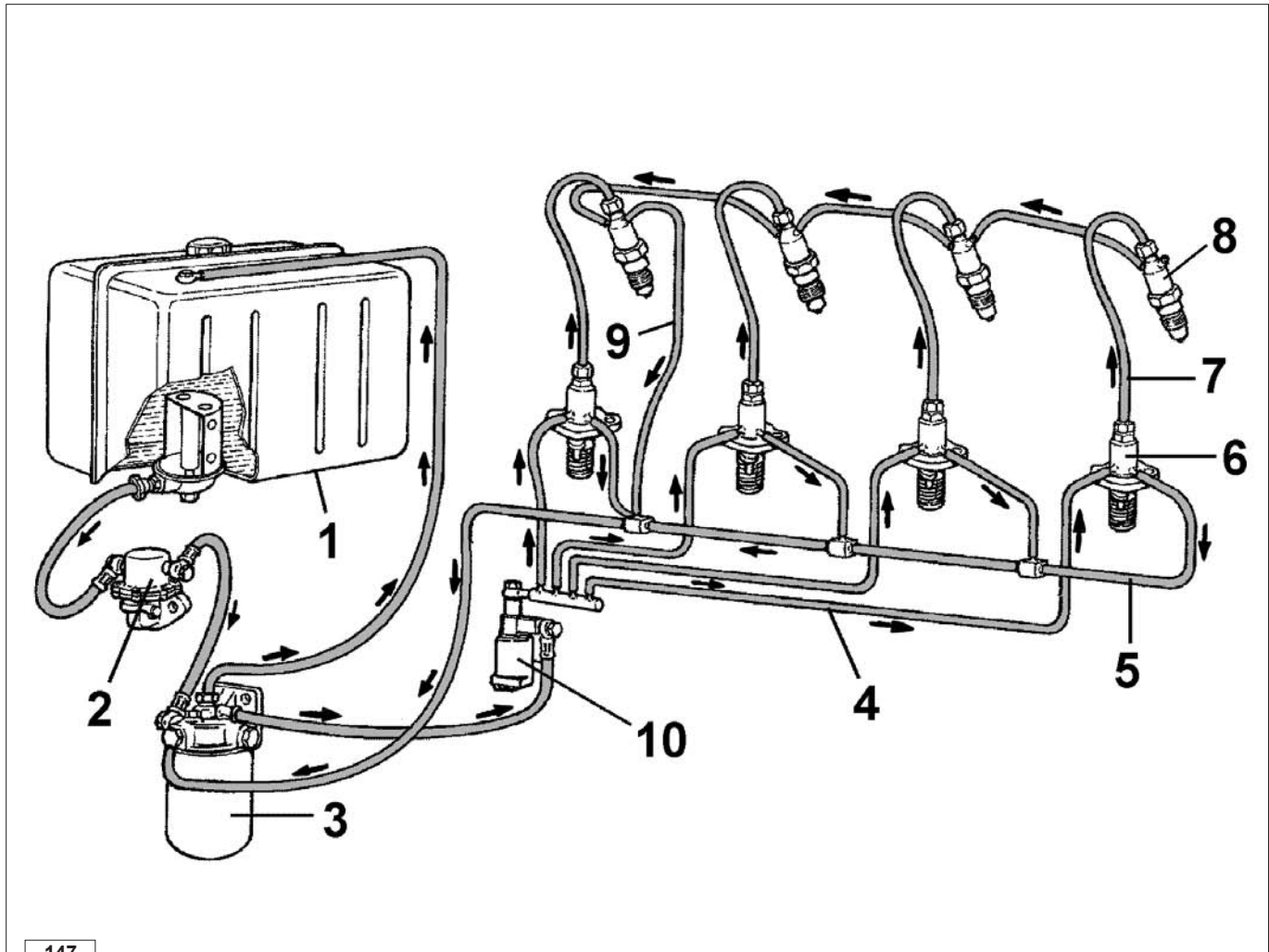
When refuelling, it is advisable to use a funnel to prevent fuel from spilling out. The fuel should also be filtered to prevent dust or dirt from entering the tank. Use the same type of diesel fuel as used in cars. Use of other types of fuel could damage the engine. Do not use dirty diesel fuel or mixtures of diesel fuel and water since this would cause serious engine faults.

FUEL SYSTEM

147

Components:

- 1 - Tank
- 2 - Fuel feeding pump
- 3 - Fuel filter
- 4 - Fuel delivery tube
- 5 - Injector pumps overflow tube
- 6 - Injection pump
- 7 - High-pressure tube between pump and injector
- 8 - Injector
- 9 - Injector return tube
- 10 - Solenoid valve

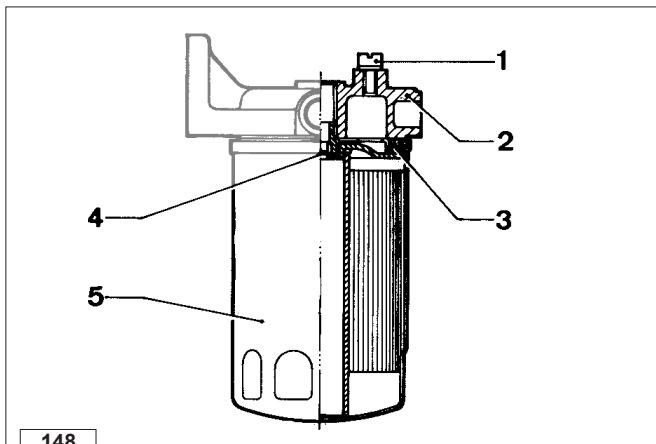

148

Fuel filter

- Components:*
 1 - Drain screw
 2 - Cover
 3 - Seal
 4 - Fitting
 5 - Cartridge

Cartridge specifications

Filtering paper:..... PF 904
 Filtering area:..... 5000 cm²
 Filtering degree:..... 2/3 m
 Max. working pressure: 4 bar

➡ See page 22 for maintenance details.

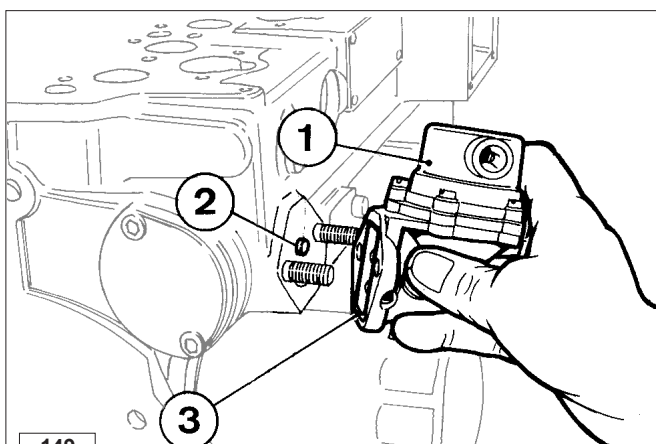

149

Fuel feeding pump

- Components:*
 1 - Feeding pump
 2 - Push rod
 3 - Seal ring

The fuel feeding pump is of the diaphragm type operated by a camshaft eccentric through a push rod.
 It features an external lever for manual operation.

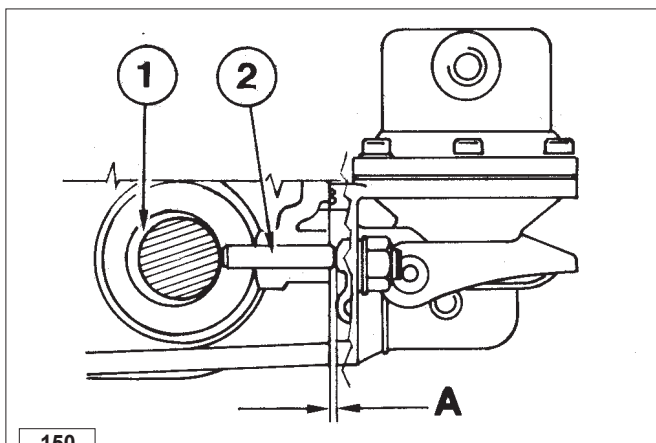

150

Fuel feeding pump drive rod protrusion

Push rod 2 shows a protrusion **A** of 1.5÷1.9 mm from the crankcase plane. Check this value with eccentric 1 at the lowest point (on the bottom of the cam base of the camshaft).

Push rod length = 32.5÷32.7 mm.
 Check push rod length and replace push rod if size is inadequate.

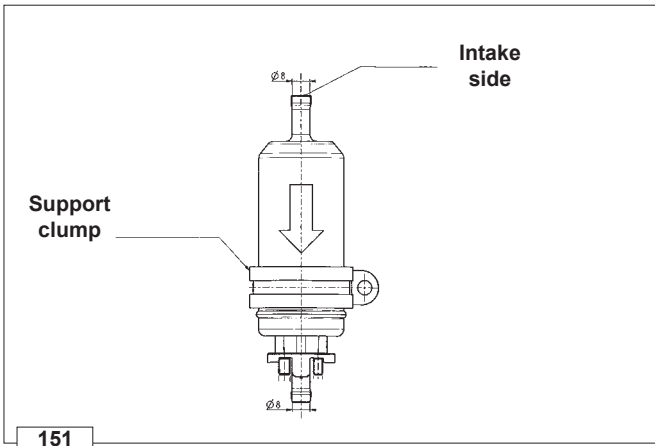

151

Electric fuel pump (24V)

The use of the electric pump is foreseen for certain applications (where the engine has to be started at very low temperatures).

Assembly notes:

When the electric fuel pump is installed in a diesel engine, it is necessary to:

- 1) Remove the filter fitted at the pump intake (intake side).
- 2) Insert the prefilter upstream of the pump (intake side).
- 3) The electric pump on the application must be at such a height from the minimum tank level that it generates a maximum pressure drop equal to a column of 500 mm of water.
- 4) Avoid running dry due to emptying of the intake pipeline, inserting a non-return valve.

Features:

Pressure: 0.44 / 0.56 bars

Max capacity: 100 l/h

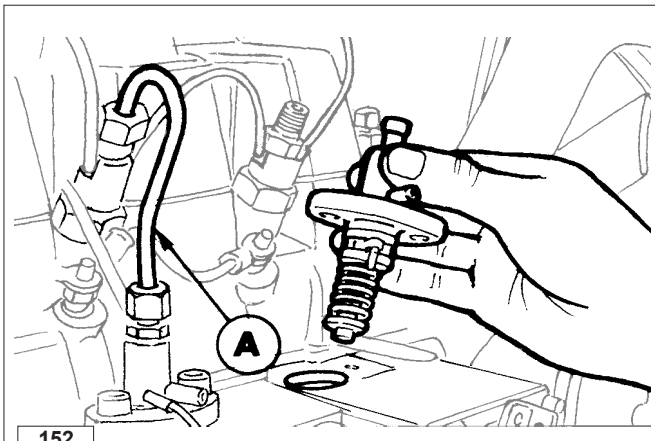

152

Injection pump

The injection pump of a simplified Q type has been designed by KOHLER for installation on engines of the KDW 1603-2204-2204/T series.

The injection system includes three or four separate pumps each of which feeds a cylinder.

Located on the crankcase at the level of the corresponding cylinder, pumps are directly operated by the camshaft.

All high pressure tubes between injector and pump A feature the same shape and dimensions.

Features	1603-2204	2204/T
Pumping	Ø 7 mm	Ø 7 mm
Sealing valve	Volume 25 mm ³ 1 hole Ø 0,81	Volume 25 mm ³ 3 holes Ø 1,5

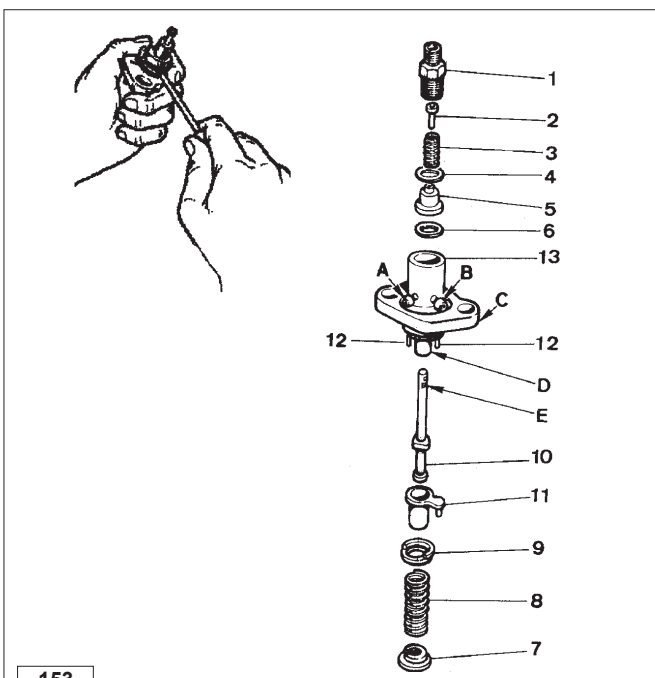

153

Injection pump disassembly

Release the spring from the cap and remove the plunger.

Two pins keep the upper cap connected to the pump body; pry with a tool between the pump body and the cap.

Injection pump components:

- | | |
|------------------|--------------------|
| 1 Delivery union | 8 Spring |
| 2 Spacer | 9 Upper cap |
| 3 Spring | 10 Plunger pumping |
| 4 Gasket | 11 Lever |
| 5 Delivery valve | 12 Pin |
| 6 Gasket | 13 Body |
| 7 Cap | |

- A Fuel feed union
 B Fuel dischrge union
 C Pump flange
 D Barrel pumping
 E Fuel control helix

Note: Union A and B, flange C and barrel D form an integral part of the pump body.

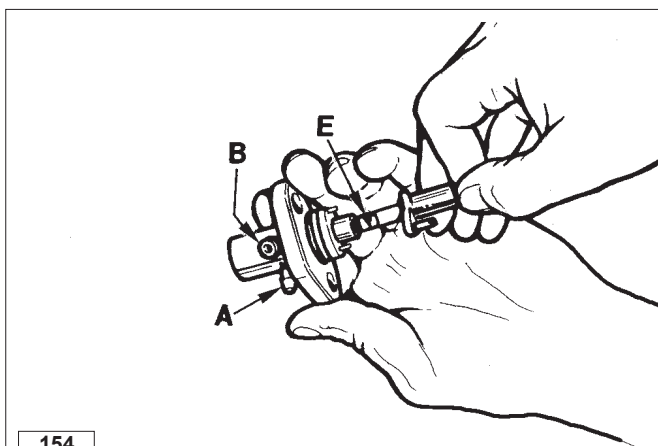

154

How to reassemble injection pump components

Fit the plunger with helix **E** directed towards the discharge union **B**; if it is erroneously fitted with spiral facing the fuel feed union **A** the injection pump will not operate (thus the possibility of the engine overspeeding is completely ruled out); complete reassembly following fig. 154

- Tighten delivery union to 35 Nm; it is essential to use a torque wrench.

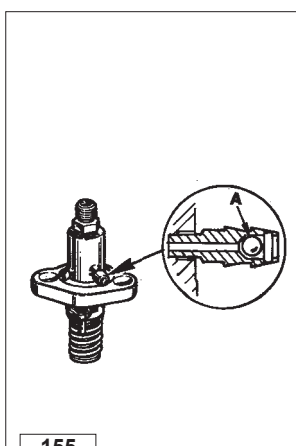

155

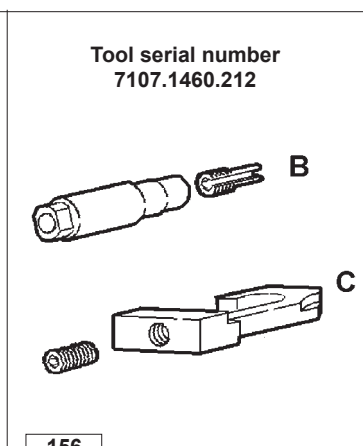

156

Injection pump non-return valve

The discharge union is fitted with a non-return valve **A**; this valve improves injection by bleeding the air inside the fuel and stops the engine immediately after the stop device is operated. To replace the outlet union with non-return ball valve on QLC type injection pumps (having inlet and outlet unions pressure-fitted on the pump case) use the special tool serial number 7107.1460.212. Tool **B** is required for removal of valve **A**, tool **C** for driving.

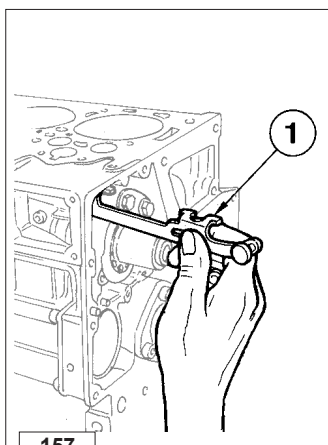

157

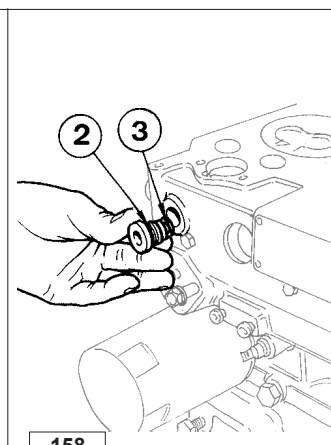

158

Injection pump control rod



Caution – Warning

Do not unscrew ring nut 2 before removing rod 1.

Control rod **1**, operated by the throttle and governed by the speed governor, controls the injection pump. Ring nut **2** keeps rod **1** in the required position by means of groove **3**.

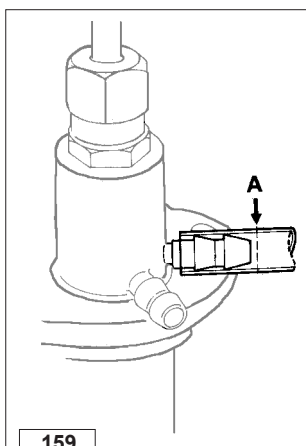

159

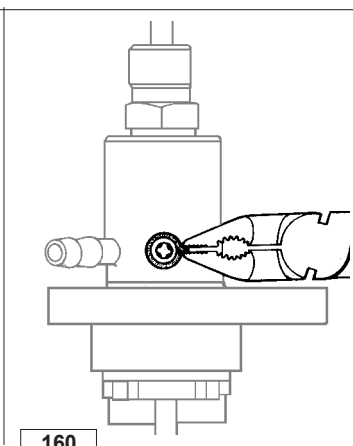

160

How to remove injection pump feeding tubes



Caution – Warning

Cutting the pipe in the opposite direction to the arrow **A (horizontally) damages the pump coupling with consequent leakage of fuel.**

Cut the nylon tube at **A**. Remove the portion left inside the union using pliers. Remove the nylon tube without damaging the union seals as shown in the figure 159.

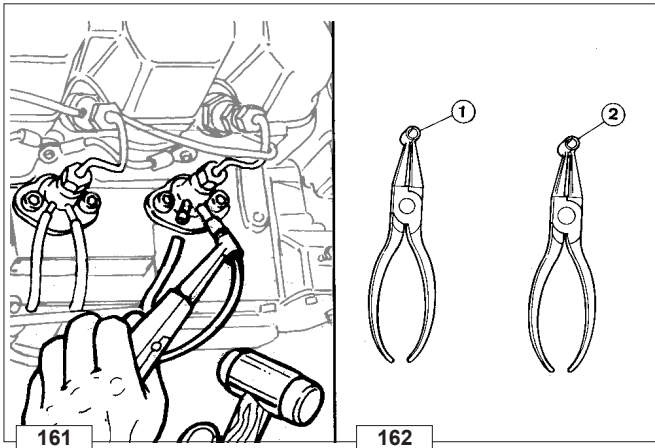

How to reassemble injection pump feeding tubes

- 1 Pliers for 6 mm diam. tubes (intake) - Part No. 7104-1460-022
- 2 Pliers for 8 mm diam. tubes (discharge) - Part No. 7104-1460-023

Feeding and discharge tubes are made of nylon; they fit into the injection pump unions by exerting pressure and using special pliers and a plastic hammer.
The nylon tubes can no longer be used after disassembly. Replace them every time they are removed.

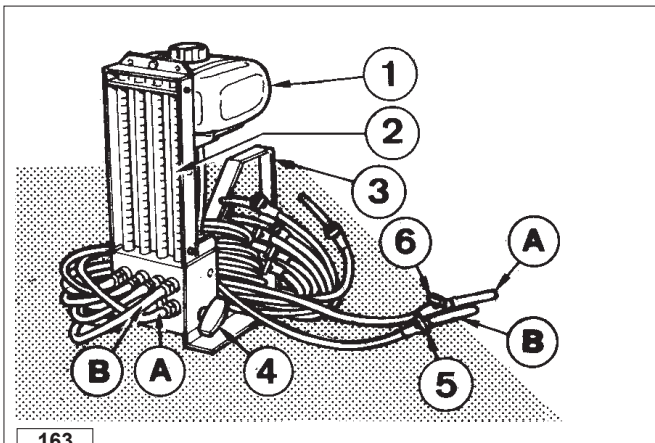

Instrument for equalizing injection pump delivery
Part No. 7104-1460-090

- Components:
- 1 Tank
 - 2 Test tube
 - 3 Support
 - 4 Switching lever
 - 5 Injection pump discharge tube cut-off valve
 - 6 Injection pump intake tube-off valve

A Tube for connection to injection pump intake union
B Tube for connection to injection pump discharge union

Remove feed tubes from all injection pumps and fit the instrument tubes making sure that each pump has its own intake and discharge tubes. Connect the instrument A with the engine A and the instrument B with the engine B. Proceed in a similar manner with the other pumps.

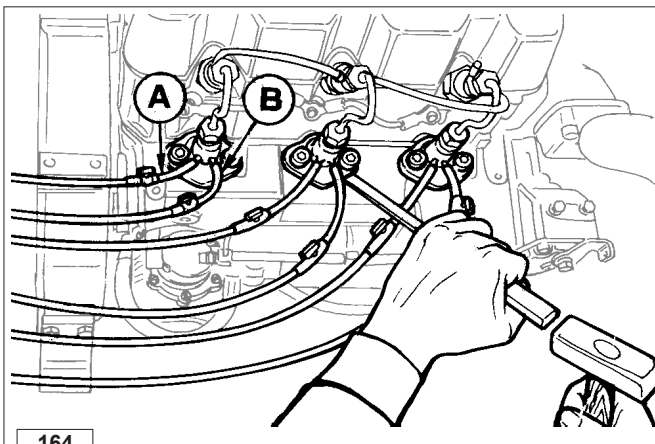

Injection pump delivery equalization

After checking the injection advance go ahead with the delivery balancing of the pumps.
Before connecting the tool serial number 7104-1460-090 to the pumps and refilling tank 1 with fuel, set it to a higher level of at least 200 mm than that of the pumps themselves.
Open taps 5 and 6 and start the engine, set the engine to an idling speed of 2000 rpm. Switch the engine feed from tank 1 to the tubes 2 using the switching lever 4 fig. 163.
After the first minute (minimum testing time), verify that the level between the highest and lowest levels in the tubes is not more than 2 cm³.
At this point, it is possible to either reduce the delivery of the pump that consumes most (tube with the lowest level) or increase the delivery of the pump that consumes the least (tube with the highest level).

To vary the delivery of the pumps, rotate slightly in one direction or the other at the injection pumps.
Unscrew the fastening screws of the pump to be adjusted by a quarter of a turn.
Rotating clockwise the delivery is increased, anti-clockwise the delivery is reduced.

- Once adjustment is finished, tighten the fastening screws to 25 Nm.

Important

Whenever an injection pump is disassembled or replaced, delivery balancing must be carried out.

Note: A reference notch is located between the pump flange and its mounting on the crankcase. If one or more pumps are disassembled and reassembled do as follows:

- Make a reference marking on the fastening flanges of the injection pumps and on the base planes of the crankcase.
- Leave the shims for injection timing setting under each pump unchanged.
- Each pump should be reassembled in its own housing.

Align the delivery reference notches located on the pump flange with those on the crankcase.

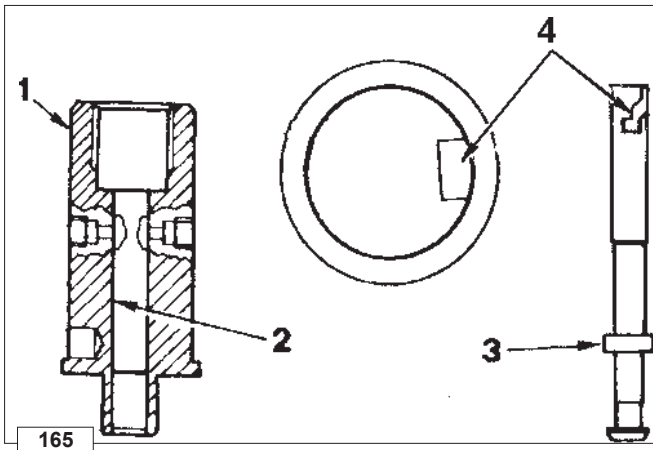

**Injection pump P. No. 6590-249
Plunger and barrel assembly**

Components:

- 1 Pump body
- 2 Barrel
- 3 Plunger
- 4 Plunging blade

Note: Barrel 2 forms an integral part of the pump body 1.
For this reason both the barrel and plunger 3 should not be replaced.

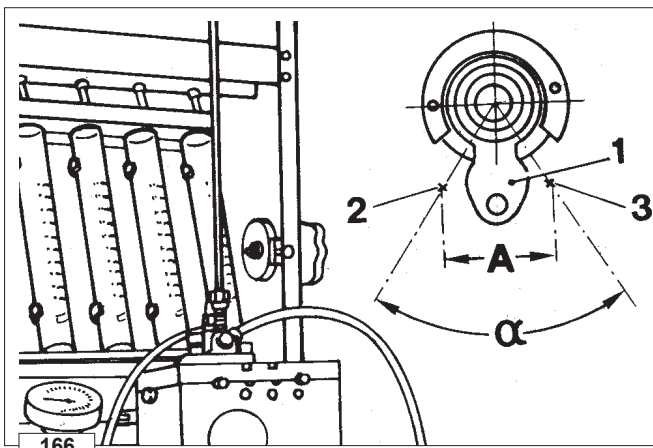

Checking injection pump delivery

Components:

- 1 Delivery adjustment rod
- 2 Rod 1 stop position
- 3 Rod 1 max. delivery position
- A = 18.5 ÷ 19.5 mm (rod max. stroke)
- α = 66° (rod max. rotation)

Test data of injection pump

Control rod max. force Newton	Rod stroke from max. delivery point (mm)	Camshaft rpm	KDW 1603-2204 Delivery mm ³ /stroke	KDW 2204/T Delivery mm ³ /stroke
0,35	9	1500	31 ÷ 41	40 ÷ 48
		500	23 ÷ 33	20 ÷ 28
	0	150	56 ÷ 66	58 ÷ 64

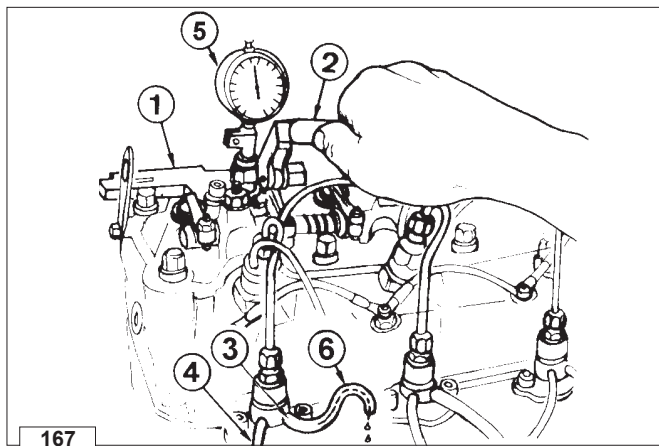

167

Checking low pressure injection timing for engines with hydraulic tappets

To verify the delivery starting point, the first operation to carry out is to disconnect the nylon tubes at the inlet 4 and outlet 3 of every injection pump.

Then, disassemble the air filter, the intake manifold and the rocker arm cap.

Now disassemble the whole rocker-arm pin and, after removing the push rods, reassemble it.

Screw the special tool 1 serial number 7107-1460-075 (fig. 167) onto the head, making sure the dial indicator tracer 5 sets against the upper spring bearing ring of the intake valve.

Use a provisional fuel tank (e.g. delivery balancing tool) to gravity-feed the injection pump connecting it to the inlet union 4; on the outlet union 3 fit the transparent nylon tube 6 by the means of which we measure the overflow.

Place the pump control rod in the stop position.

Operate the lever 2 of the tool to rotate the crankshaft until the valve touches the piston crown.

This procedure determines the exact TDC (top dead centre of the piston) of the cylinder in question; reset the dial indicator in this position.

Then rotate clockwise the crankshaft on the flywheel side until diesel fuel begins to flow out of the small hose on the pump outlet.

Now change the rotation direction to anticlockwise.

The flow diminishes.

As soon as it stops flowing, the delivery starting point is determined.

Then, lower the tool lever to make contact between the valve and the piston crown and, using the dial indicator 5, measure how much lower the piston is with respect to the TDC (top dead centre) in mm.

Use the transformation chart (mm to degrees) to find out the correspondence between mm measured with the dial indicator 5 and degrees.

Example **KDW 1603-2204-2204/T**: an advance of $\alpha=15^\circ$ corresponds to a lowering of the piston with respect to the TDC (top dead centre) of 2,00 mm.

a	KDW 1603_2204_2204/T (mm)
16°	2,27
15°	2,00
14°	1,74
13°	1,50
12°	1,28
11°	1,08
10°	0,89
9°	0,72
8°	0,57
7°	0,43
6°	0,32
5°	0,22
4°	0,14
3°	0,08

- The same operation must be carried out on each pump.
- The difference in adjustment must be limited to about 1°.
- Disassemble the various equipment, remove the rocker-arm pin and put back the push rods in their seats. Then re-assemble the rocker-arm pin.
- Rotate the crankshaft so as to position the pistons at half stroke for three-cylinder engines.
- For four-cylinder engines, place the piston of cylinder number one at 150° after the top dead centre (in crossover stage).
- The rocker-arm pin must be fastened in different stages so as to allow the oil inside the tappets to be drained, thus allowing them to position themselves correctly.
- Oil density and ambient temperature are important factors that will affect the waiting time (about 10') between successive fastening operations.
- **Hurried fastening can cause serious damage to the engine.**
- As a guideline to each fastening operation, make sure that the cup of the upper spring bearing ring does not touch the valve stem oil sealing ring fitted on the guide.
- The final torque of the rocker-arm pin is 50 Nm.
- Reassemble the rocker-arm cap and the intake manifold, tightening the screws to the indicated torque.

Engine type	Injection timing value for r.p.m. \geq 2400	Injection timing value for r.p.m. \leq 2400
KDW 1603 2204	$13^{\circ} \pm 1^{\circ}$	$11^{\circ} \pm 1^{\circ}$
KDW 2204/T	$7^{\circ} \pm 1^{\circ}$	$4^{\circ} \pm 1^{\circ}$

Checking low pressure injection timing for engines with mechanical tappets

The check of the advance on engines with mechanical tappets is carried out using the same procedure as that described for the hydraulic tappets; the only difference is in the disassembly and reassembly of the rocker-arm pin and of the push rods which is not necessary.

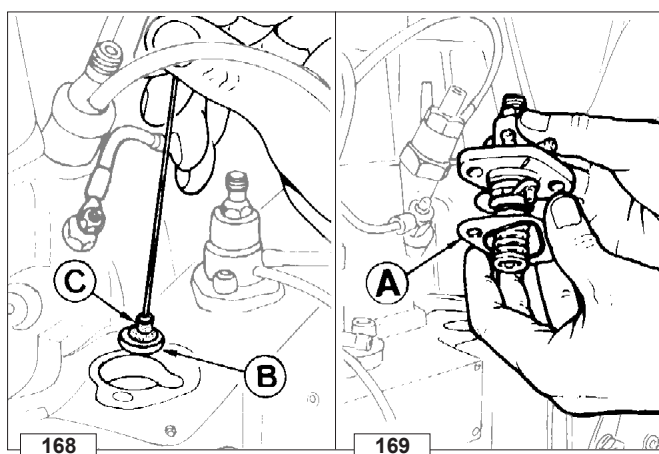

Injection timing correction by changing the pad thickness

Should it be necessary to correct the injection static advance, remove the injection pump from the engine block and replace pad **B** inside the injection tappets with one of a different thickness (to extract pad **B** use a magnet **C**).

Its value is printed on the lower part of the pad.

Twelve spare pads are supplied for the advance variations and their thickness can vary from 4 to 5.1 mm.

The gasket **A**, between the injection pump flange and the engine block, is only one, with the only task of preventing any possible oil leaks.

Previously, to vary the injection advance, gaskets of different thicknesses were used between the injection pump surface and the engine block surface (in effect, gasket **A** without sealing rubber border).

Spacer	Colour
4.0	No colour
4.1	White
4.2	Yellow
4.3	Orange
4.4	Light blue
4.5	Green
4.6	Blue
4.7	Red
4.8	Gray
4.9	Violet
5.0	Light gray
5.1	Brown

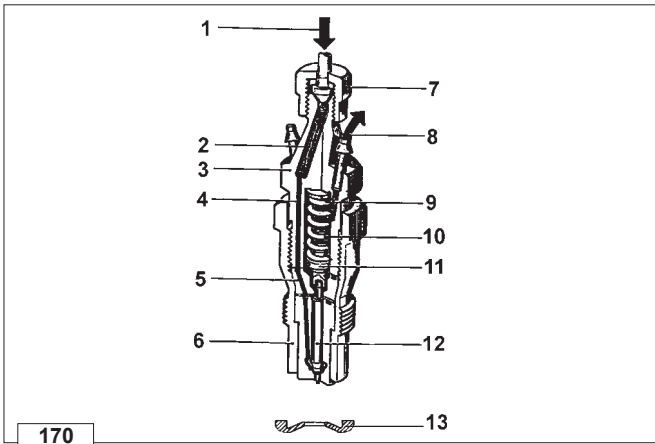

Injector (pin type)

Components:

- | | |
|---------------------|-----------------------|
| 1 Fuel inlet | 7 Delivery union |
| 2 Filter | 8 Backflow union |
| 3 Body | 9 Setting shims |
| 4 Delivery duct | 10 Pressure spring |
| 5 Pad | 11 Pressure pin |
| 6 Clamping ring nut | 12 Nozzle |
| | 13 Fireproof bulkhead |

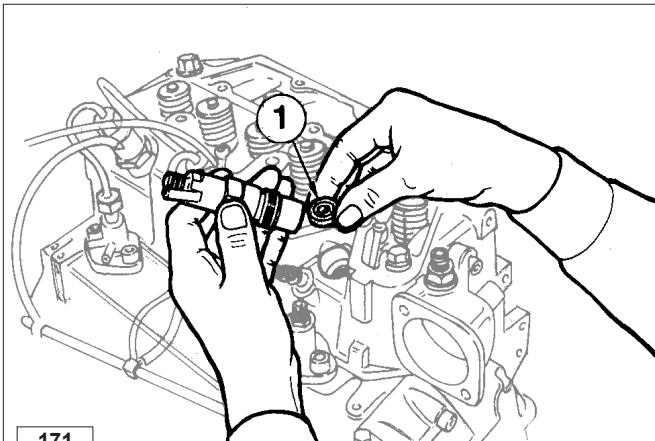

Whenever maintenance operations are carried out on the injector replace the seal ring 1. Introduce seal ring 1 into the injector housing with the sealing surface facing upwards (see figure 171).

- ➡ See page 22 for maintenance intervals.
- Fix injector to the head tightening to 70 Nm.

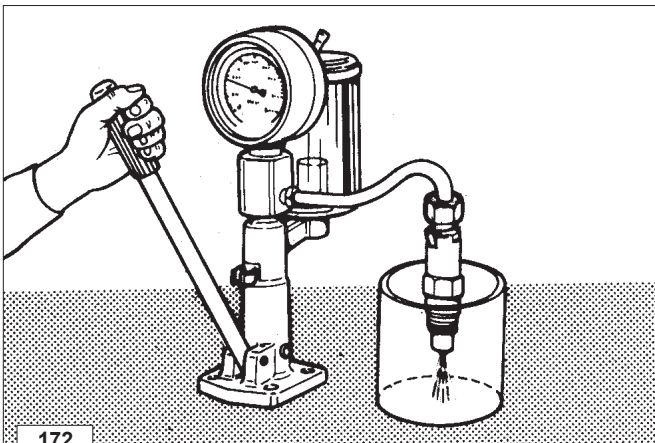

Injector setting

Connect the injector to a injection test stand and check that the pressure setting is 140 / 150 bar. Adding the shims 9 increases the pressure setting, reducing their number lowers it. Eleven spare setting shims are included, their measurements range from 1 to 2 mm. When spring 10 is replaced, calibration must be carried out at a pressure 10 bars higher than the nominal pressure (160 bar) to counterbalance bedding in the operation. Check needle valve sealing by slowly moving the hand pump until approximately 120 bar per 10 seconds. Replace nozzle 12 in case of dripping.

- The torque of the injector ring nut is 70 ÷ 90 Nm.

Ruled area with horizontal dotted lines for notes.

Wiring diagram with alternator 12V 45A / 65A / 80A

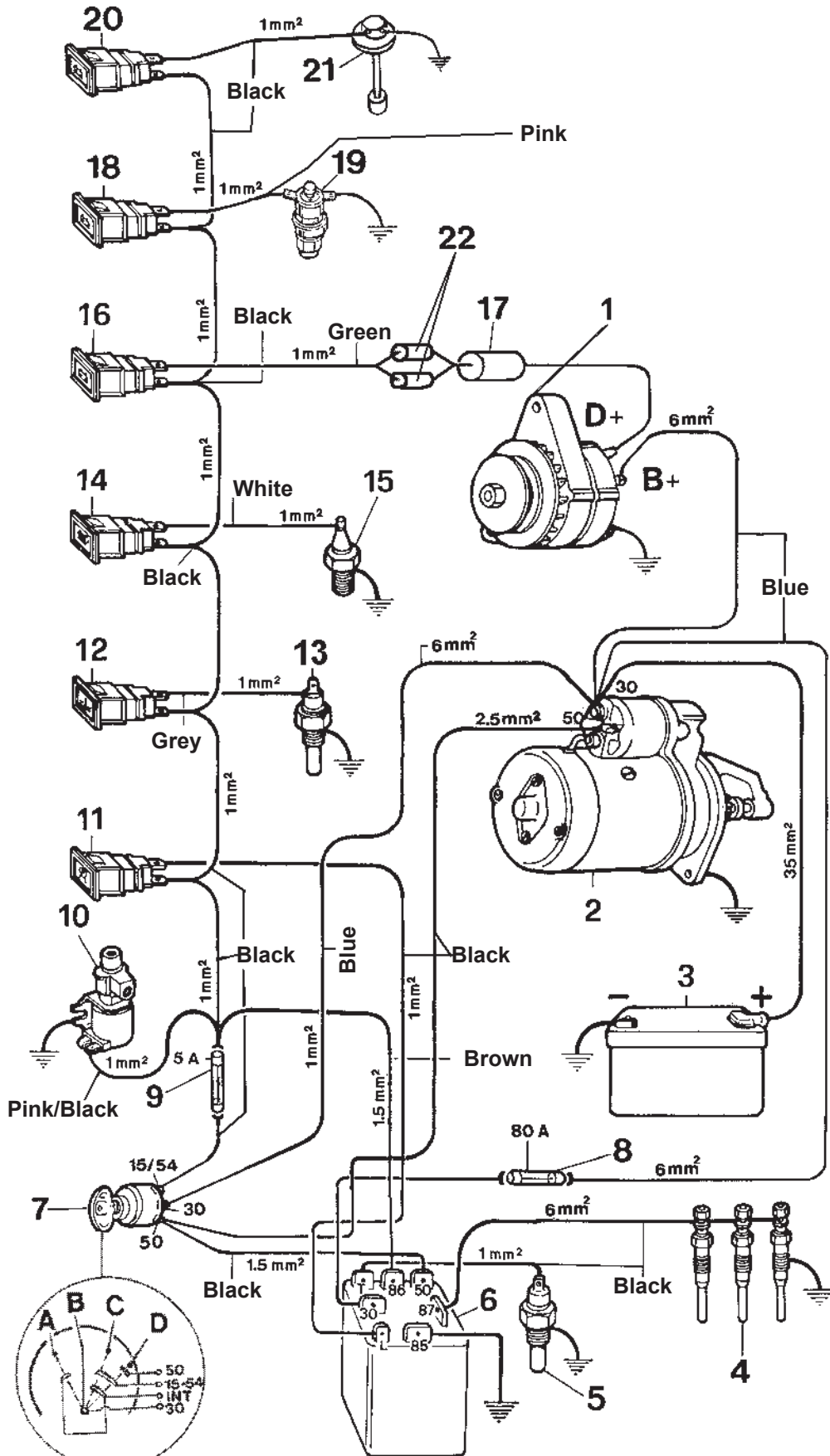

Wiring diagram with alternator 12V 45A / 65A / 80A

- 1 Alternator
- 2 Starter Motor
- 3 Battery (See below for sizing details)
- 4 Glow Plugs
- 5 Thermistor (Glow Plug Controller Circuit)
- 6 Glow Plug Controller / Timer
- 7 Key Switch
- 8 System Fuse
- 9 Fuse (Accessory)
- 10 Fuel Valve
- 11 Glow Plug Indicator Lamp
- 12 Coolant High Temperature Lamp
- 13 Coolant High Temperature Switch (N.O.)
- 14 Oil Pressure (Low) Lamp
- 15 Oil Pressure Switch (N.C.)
- 16 Alternator Charging Lamp (Off if Charging)
- 17 Diode
- 18 Air Filter High Restriction Indicator
- 19 Air Filter Restriction Switch (N.O.)
- 20 Low Fuel Level Lamp
- 21 Low Fuel Level Switch (N.O.)
- 22 n. 2 100 ohm resistances in parallel

- A Accessory
- B Off Position
- C On Position
- D Starting Position

Battery 3 is not supplied by KOHLER.



Battery not supplied. Ground rubber mounted engines.

RECOMMENDED BATTERIES

In Standard Start Conditions	In Heavy-Duty Start Conditions
12 V - 92 Ah/450 A/DIN 12 V - 92 Ah/880 A/EN 12 V - 92 Ah/715 A/SAE	12 V - 110 Ah/500 A/DIN 12 V - 110 Ah/980 A/EN 12 V - 110 Ah/790 A/SAE

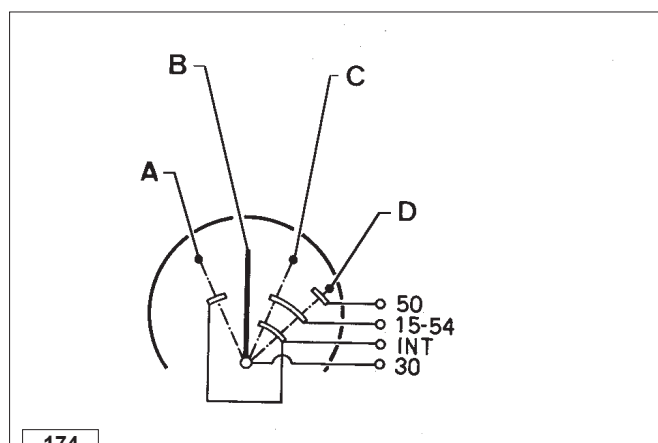

174

Key switch electrical layout

- A = Accessory
- B = Off position
- C = On position
- D = Starting position

Alternator type Marelli AA 125 R 14V 45A

Characteristics:

Rated voltage14V
 Rated current.....45A
 Max. speed.....14000 giri/1'
 Peak speed (max 15 min).....15000 rpm
 Bearing on control side.....6203.2z
 Bearing on manifold side.....6201-2z/C3
 Voltage regulatorRTT 119 AC
 RH direction of rotation.

○ Tighten the nut 1 to 60 Nm.

Note: Lube the two bearings with high temperature grease.
 The alternator has a **W** terminal for a speed indicator.

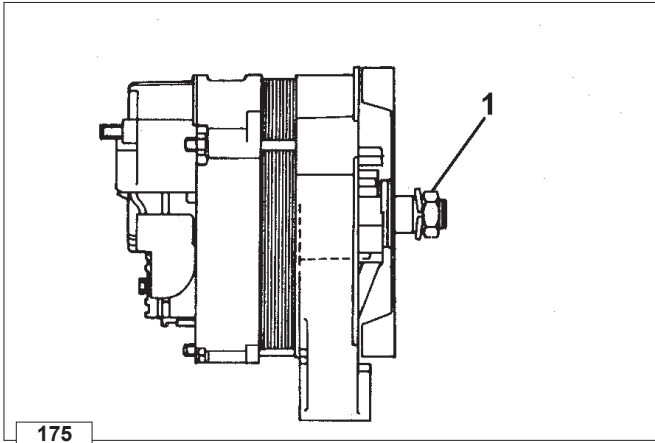

175

Characteristic curves for alternator type Marelli AA 125 R 14V 45A

The curves have been detected with electronic voltage regulator after thermal stabilization at 25°C; test voltage 13.5 V.

P1 = Power in kW
I = Current in Ampere
 η = Alternator efficiency

Note: The alternator rpm is equal to to the rpm shown in the table multiplied by 1000.
 Ratio between engine/alternator rpm = 1:1.8

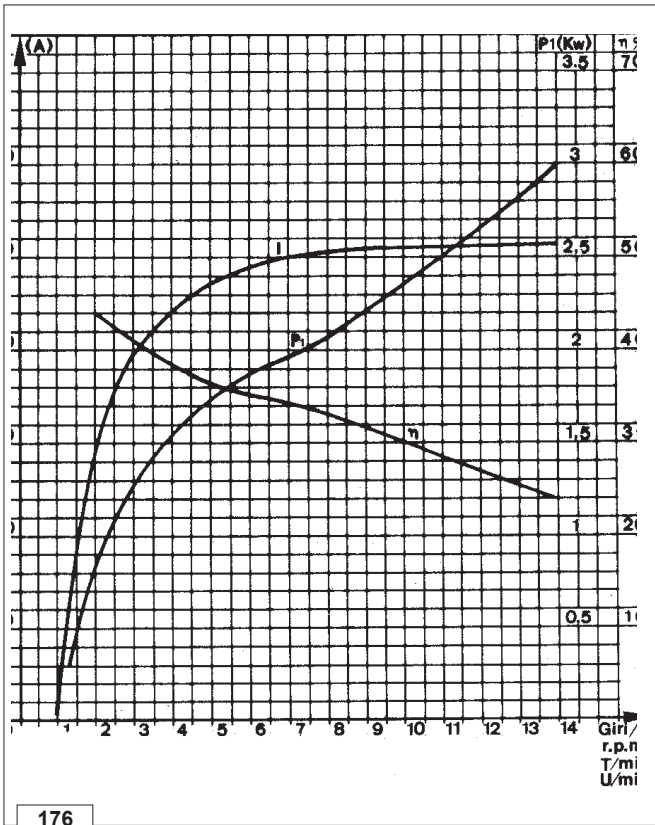

176

Characteristic voltage curve for regulator type RTT 119 AC

The electronic voltage regulator is built into the alternator.
 The curve changes depending on temperature.

A = Max. voltage curve
B = Min. voltage curve

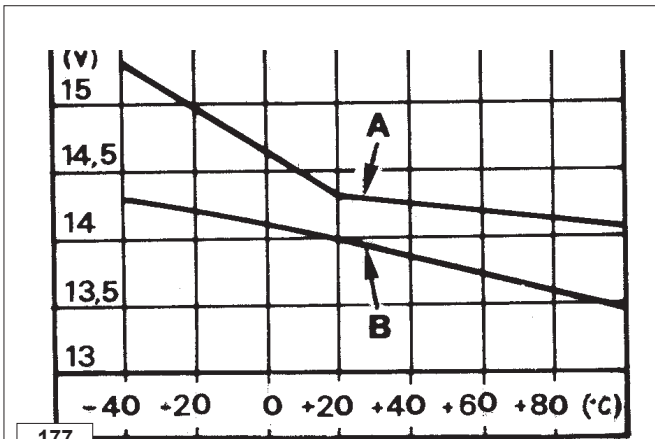

177

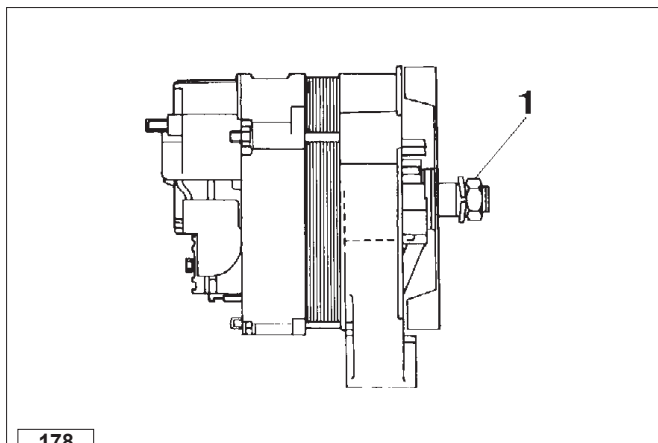

178

Alternator type Marelli AA 125 R 14V 65A

Characteristics:

- Rated voltage14V
- Rated current.....65A
- Max. speed14.000 giri/1'
- Peak speed (max 15 min)15.000 rpm
- Bearing on control side.....6203.2z
- Bearing on manifold side.....6201-2z/C3
- Voltage regulatorRTT 119 AC
- RH direction of rotation.

○ Tighten the nut 1 to 60 Nm.

Note: Lube the two bearings with high temperature grease.
The alternator has a W terminal for a speed indicator.

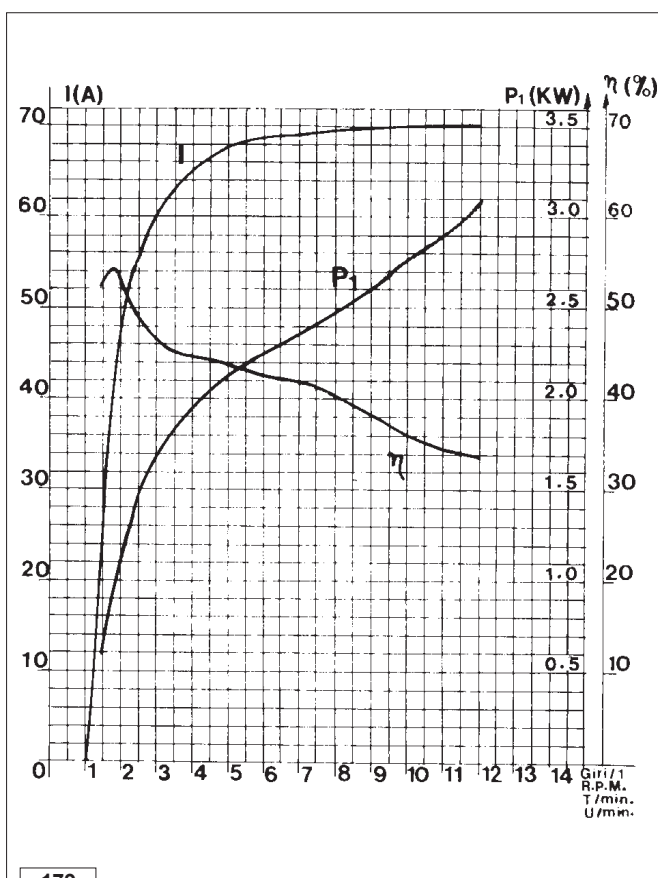

179

Characteristic curves for alternator type Marelli AA 125 R 14V 65A

The curves have been detected with electronic voltage regulator after thermal stabilization at 25°C; test voltage 13.5 V.

- P1 = Power in kW
- I = Current in Ampere
- η = Alternator efficiency

Note: The alternator rpm is equal to the rpm shown in the table multiplied by 1000.
Ratio between engine/alternator rpm = 1:1.8

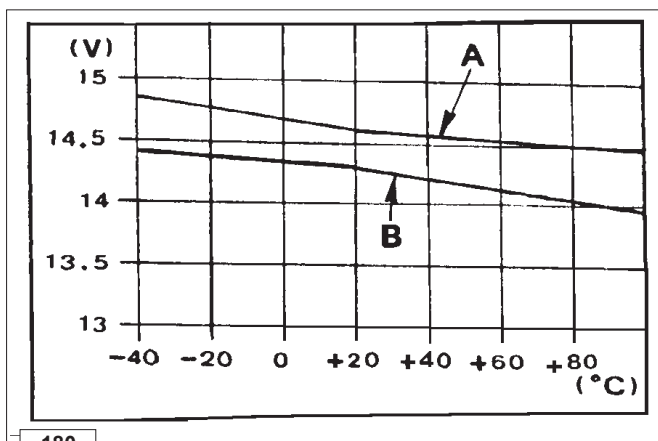

180

Characteristic voltage curve for regulator type RTT 119 AC

The electronic voltage regulator is built into the alternator.
The curve changes depending on temperature.

- A = Max. voltage curve
- B = Min. voltage curve

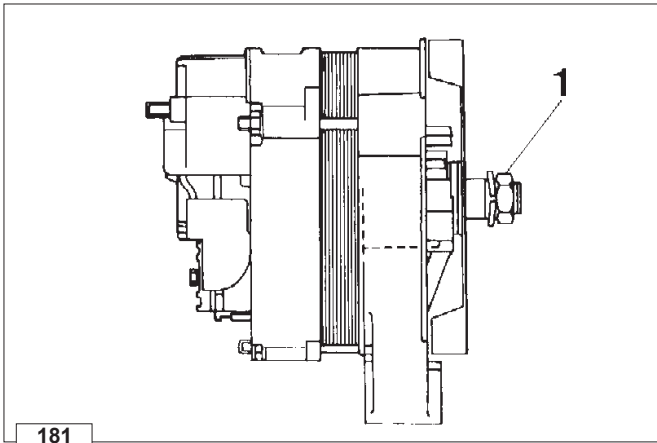

181

Alternator type Iskra, AAK3139 14V 80A

Characteristics:

Rated voltage	14V
Rated current.....	80A
Speed of the load starting point.....	1350 rpm
Maximum permanent intermittent speed (max. 15').....	13000 -15000 rpm
Front bearing	6303 - 2RS - C3
Rear bearing.....	6201 - 2RS - C3
Max. force on the bearing	600 N
Voltage regulator	AER 1528
RH direction of rotation.	

○ Tighten the nut **1** to 60÷70 Nm.

Note: Lube the two bearings with high temperature grease.
The alternator has a **W** terminal for a speed indicator.

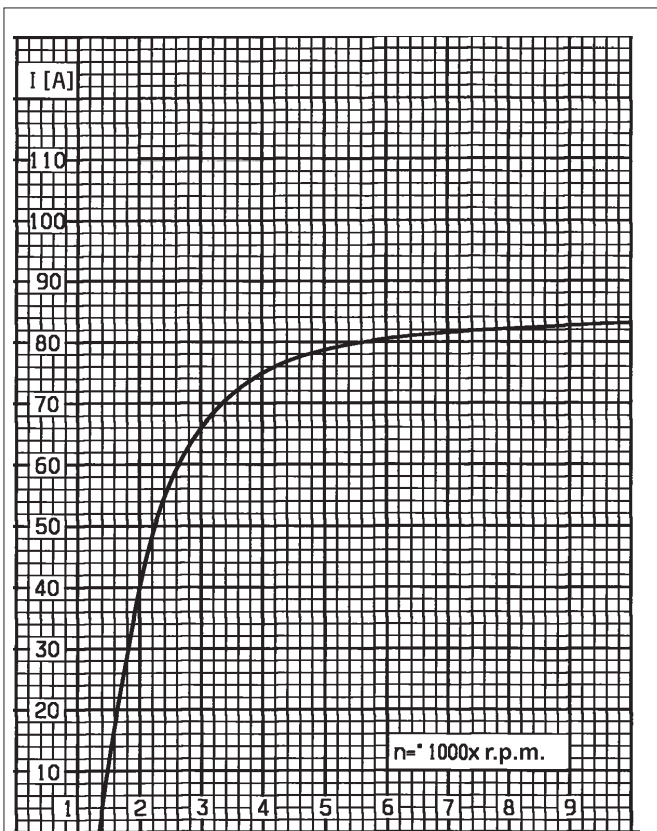

182

Characteristic curves for alternator type Iskra, AAK3139 14V 80A

The curves have been detected with electronic voltage regulator after thermal stabilization at 23 ± 5°C; test voltage 13 V.

I = Current in Ampere

Note: The alternator rpm is equal to the rpm shown in the table multiplied by 1000.
Ratio between engine/alternator rpm = 1:1.8

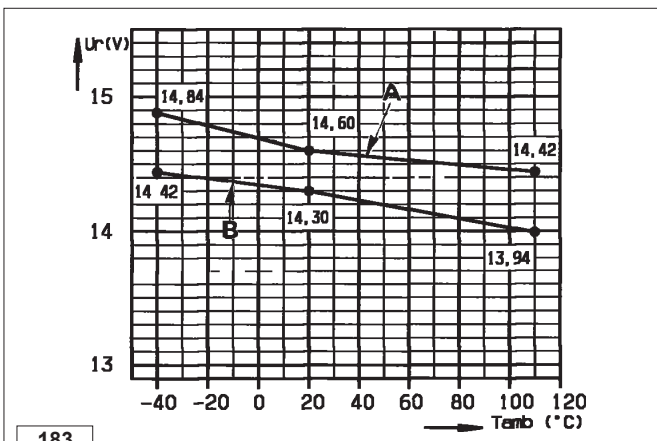

183

Characteristic voltage curve for regulator type AER 1528

The electronic voltage regulator is built into the alternator.
The curve changes depending on temperature.

A = Max. voltage curve
B = Min. voltage curve

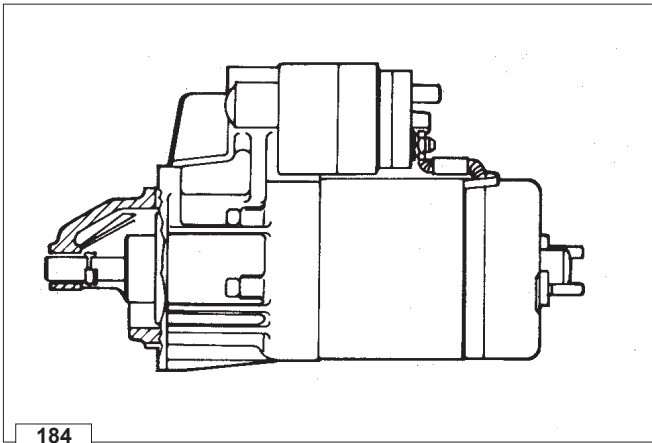

184

Starting Motor 12V

Bosch type EV 12V 2.2 Kw
RH direction of rotation.

Note: Apply to a Bosch service center for any tipe of repair.

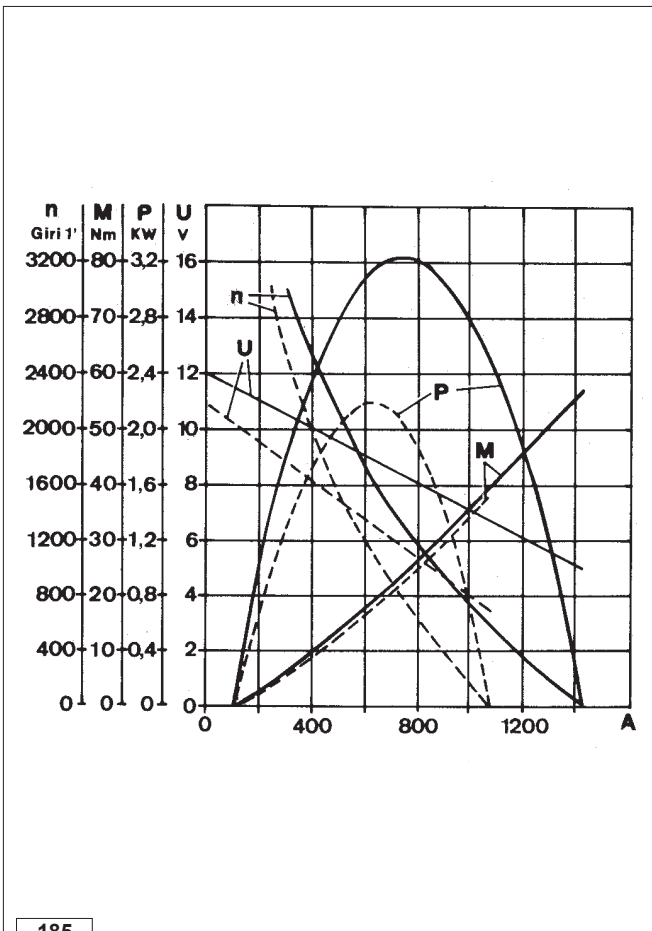

185

Characteristic curves for starting motor type Bosch EV 12V 2.2 kW

The solid lines were obtained at a temperature of +20°C; the dotted lines were obtained at a temperature of -20°C. Battery type 110 Ah 450A.

- U** = Motor terminal voltage in Volt
- n** = Motor speed in rpm.
- A** = Absorbed current in Ampere
- P** = Power in kW
- M** = Torque in Nm

Wiring diagram 24V with alternator 35A

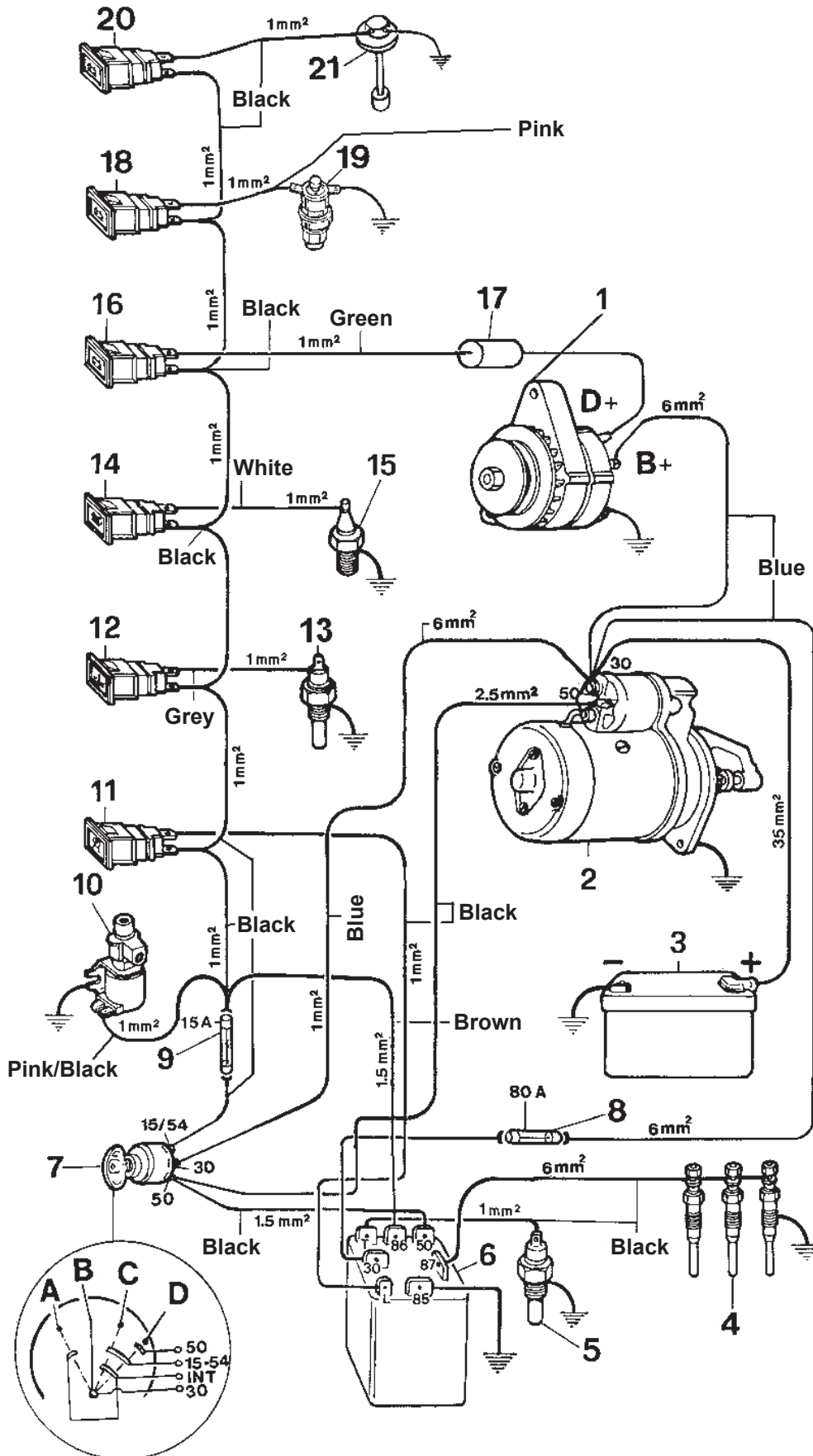

Wiring diagram 24 V with alternator 35A

- 1 Alternator
- 2 Starter Motor
- 3 Battery (See below for sizing details)
- 4 Glow Plugs
- 5 Thermistor (Glow Plug Controller Circuit)
- 6 Glow Plug Controller / Timer
- 7 Key Switch
- 8 System Fuse
- 9 Fuse (Accessory)
- 10 Fuel Valve
- 11 Glow Plug Indicator Lamp
- 12 Coolant High Temperature Lamp
- 13 Coolant High Temperature Switch (N.O.)
- 14 Oil Pressure (Low) Lamp
- 15 Oil Pressure Switch (N.C.)
- 16 Alternator Charging Lamp (Off if Charging)
- 17 Diode
- 18 Air Filter High Restriction Indicator
- 19 Air Filter Restriction Switch (N.O.)
- 20 Low Fuel Level Lamp
- 21 Low Fuel Level Switch (N.O.)

- A Accessory
- B Off Position
- C On Position
- D Starting Position

Battery 3 is not supplied by KOHLER.



Battery not supplied. Ground rubber mounted engines.

RECOMMENDED BATTERIES

In Standard Start Conditions	In Heavy-Duty Start Conditions
<p>12 V - 92 Ah/450 A/DIN 12 V - 92 Ah/880 A/EN 12 V - 92 Ah/715 A/SAE</p>	<p>12 V - 110 Ah/500 A/DIN 12 V - 110 Ah/980 A/EN 12 V - 110 Ah/790 A/SAE</p>

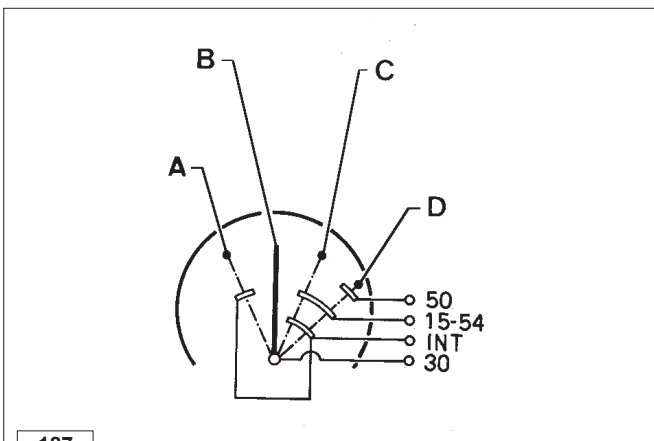

Key switch electrical layout

- A = Accessory
- B = Off position
- C = On position
- D = Starting position

187

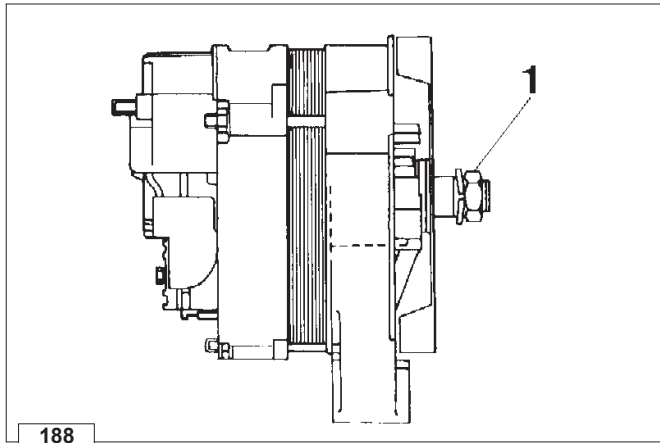

188

Alternator type Iskra, type AAK3570 28V 35A (for 24 V outfits)

- Characteristics:*
- Rated voltage 28V
 - Rated current..... 35A
 - Speed of the load starting point..... 1140 rpm
 - Maximum permanent intermittent speed (max. 15') 13000 -15000 rpm
 - Front bearing 6303 - 2RS - C3
 - Rear bearing..... 6201 - 2RS - C3
 - Max. force on the bearing 600 N
 - Voltage regulator AER 1528
 - RH direction of rotation.
 - Tighten the nut 1 to 60 ÷ 70 Nm.

Note: Lube the two bearings with high temperature grease. The alternator has a **W** terminal for a speed indicator.

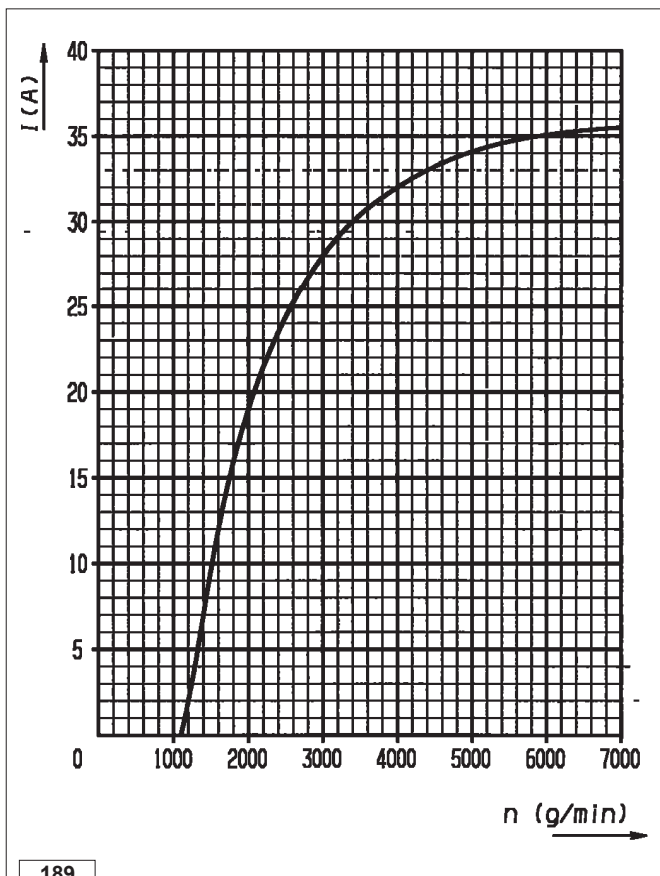

189

Characteristic curves for alternator type AAK3570 28V 35A (for 24 V outfits)

The curves have been detected with electronic voltage regulator after thermal stabilization at 23 ± 5°C; test voltage 13 V.

I = Current in Ampere

Note: The alternator rpm is equal to the rpm shown in the table multiplied by 1000. Ratio between engine/alternator rpm = 1:1.8.

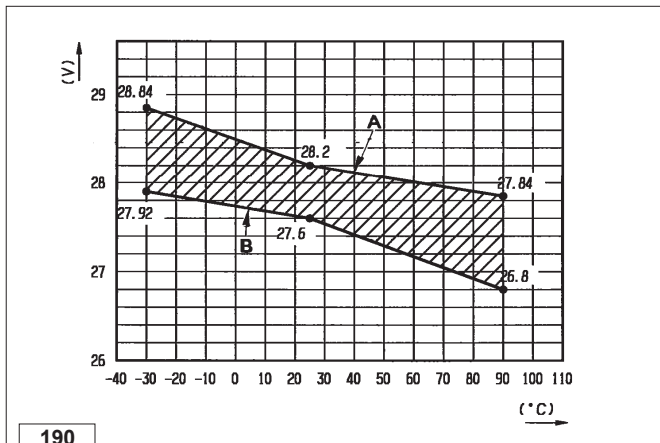

190

Characteristic voltage curve for regulator type AER 1528

The electronic voltage regulator is built into the alternator. The curve changes depending on temperature.

- A = Max. voltage curve
- B = Min. voltage curve

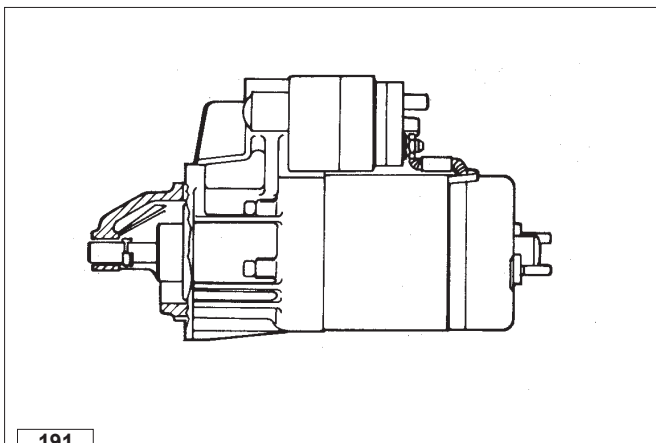

191

Starting Motor 24V

Iskra type AZE 4598 24V 3 kW
RH direction of rotation.

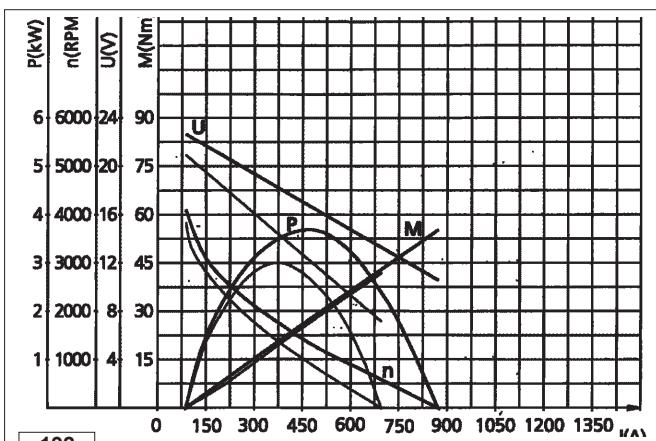

192

Characteristic curves for starting motor Iskra type AZE 4598 24V 3 kW

The thick lines were obtained at a temperature of +20°C; the thin lines were obtained at a temperature of -20°C. Battery type 55 Ah 300A.

- U** = Motor terminal voltage in Volt
- n** = Motor speed in rpm.
- A** = Absorbed current in Ampere
- P** = Power in kW
- M** = Torque in Nm

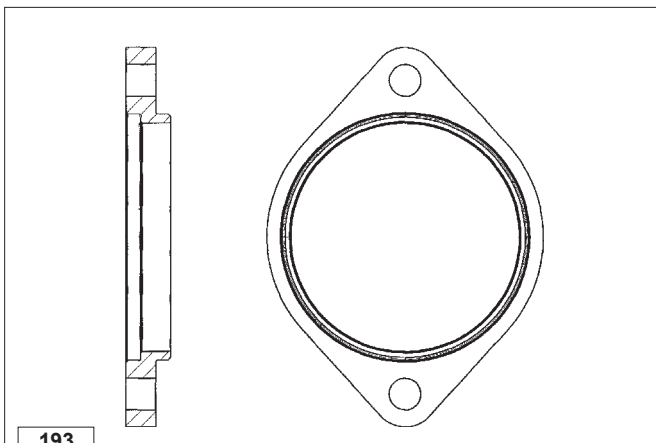

193

Spacer flange for starter motor

The 24V starter motor requires the assembling of the spacer flange.

Connection diagram for preheating control unit

Components:

- 1 Cable cross-section 2.5 mm² at point "50" of the key panel
- 2 Cable cross-section 6 mm² at the fuse holder box
- 3 Cable cross-section 1.5 mm² at the earth
- 4 Cable cross-section 1 mm² at the spark plug warning light (max. 2 W)
- 5 Cable cross-section 6 mm² at point "30" of the key panel
- 6 Cable cross-section 1 mm² at the water temperature sensor
- 7 Cable cross-section 1.5 mm² at the fuse

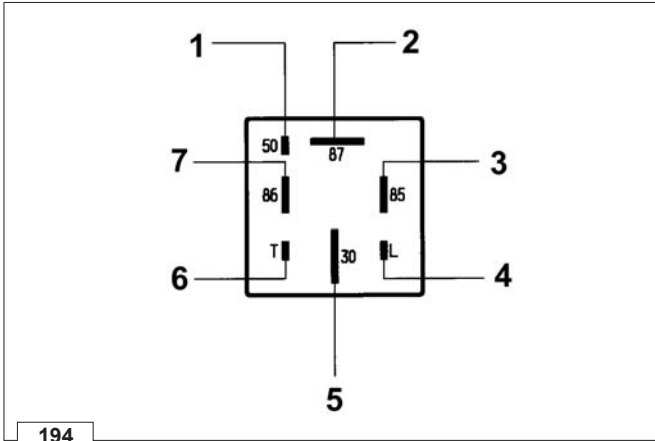

194

Glow plug controller relay with coolant temperature sensor

To avoid white smoke generation at cold start-up, post-heating is maintained for approximately 5 sec. after starting.

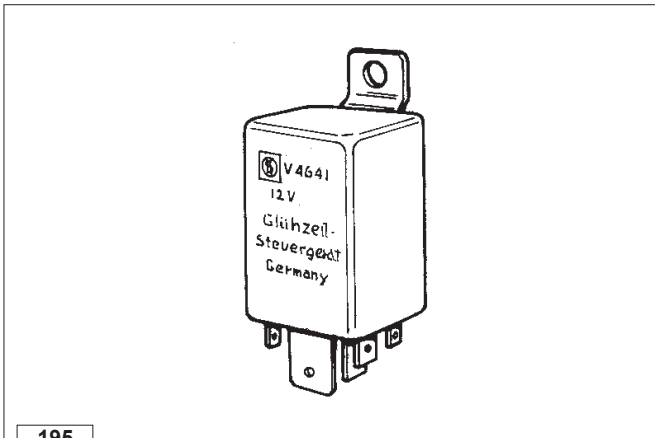

195

Trasducer		Heating time in seconds		
Resistance Ω	Temperature °C	Pre-heating 12V	Pre-heating 24V	Starting control and Post-heating
- 30	11860	-	30	4 ÷ 7
- 20	7000	23,5 ÷ 29,5	19 ÷ 23	
0	2400	13,5 ÷ 16,5	9,5 ÷ 12,5	
+ 20	1000	8,5 ÷ 10,5	5 ÷ 7	
+ 40	≤ 460	6,0 ÷ 8,0	2 ÷ 4	
+ 50	320	Stop		

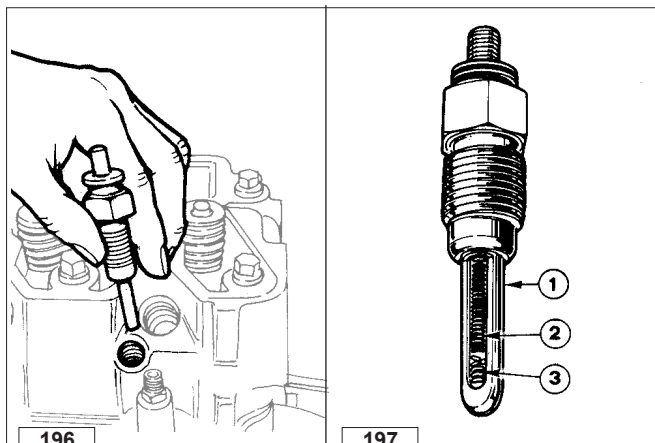

196

197

Pre-heating glow plug

- Components:
- 1 Sheath
 - 2 Regulation filament
 - 3 Heating filament

○ Installation torque 20 Nm.

Glow plug Type	12 V	24 V
Nominal voltage	11,5 V	25 V
Current	12 ÷ 14 A (after 5")	12 ÷ 14 A (after 5")
Sheath surface temperature	12 ÷ 14 A (after 5")	12 ÷ 14 A (after 5")

Note: The glow plug is not damaged in any way due to the prolonged activation time.

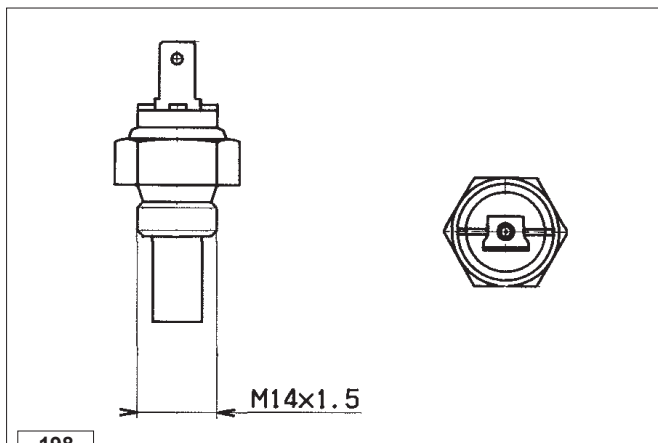

Temperature sensor (Thermistor)

The thermistor is located on the thermostat housing, adjacent to the high coolant temperature switch.
The thermistor must be installed in the thermostat housing in the port located nearest to the cylinder head. (See the figure to the left).

Characteristic:
Voltage: 6/24 V
Max. installation torque: 30 Nm.

Features of heavy-duty start sensor	
Temperature °C	Resistance Ω
+ 37.7	1125
+ 65.5	405
+ 93.3	170
+ 100	140
+ 121.1	80

Features of standard sensor	
Temperature °C	Resistance Ω
- 30	9790 ÷ 13940
- 20	6300 ÷ 7700
- 10	4900 ÷ 3600
- 0	2160 ÷ 2640
+ 20	900 ÷ 1100
+ 37.7	448 ÷ 672
+ 65.5	180 ÷ 270
+ 93.3	80 ÷ 120
+ 100	75 ÷ 95
+ 121.1	45 ÷ 55

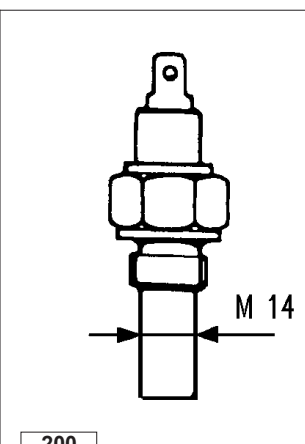
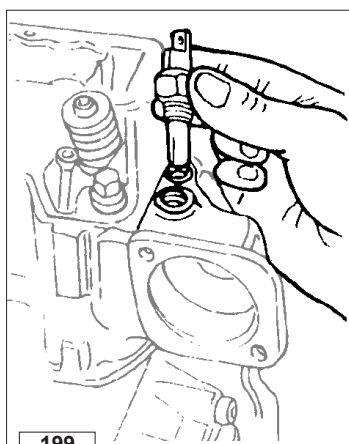

Coolant high temperature lamp switch

Characteristics:
Single-pole circuit, normally open
Supply voltage6÷24V
Absorbed power3W
Circuit closing temperature.....107÷113°C

○ When refitting tighten to 25 Nm.

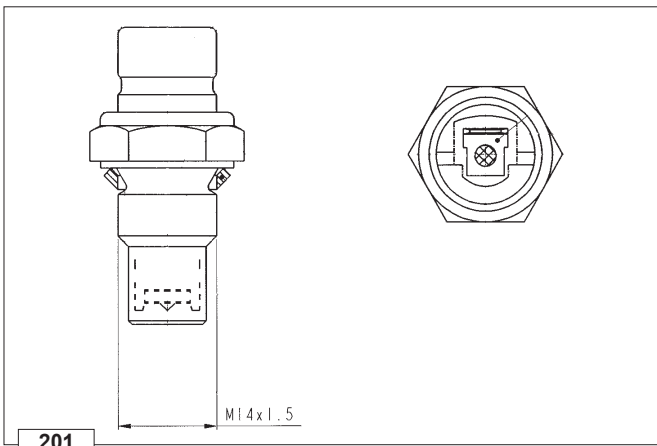

Thermistor for electric thermometer

Thermistor features	
Temperature °C	Resistance Ω
-35	73806 ÷ 53983
-30	52941 ÷ 39229
-15	20825 ÷ 18006
0	8929 ÷ 7095
+30	2040 ÷ 1718
+60	589 ÷ 521
+90	205 ÷ 189
+120	85 ÷ 87

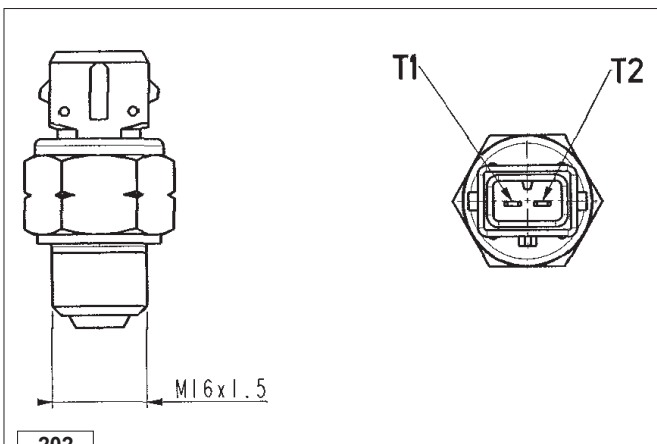

Thermistor for preheating water temperature
Thermal contact for water temperature indicator light

Thermal contact T1 features	
Temperature °C	Resistance Ω
-35	73806 ÷ 53983
-30	52941 ÷ 39229
-15	20825 ÷ 18006
0	8929 ÷ 7095
+30	2040 ÷ 1718
+60	589 ÷ 521
+90	205 ÷ 189
+120	85 ÷ 87

Thermal contact T2 features	
Circuit	Unipolar
Closing temperature	107 ÷ 113°C
Contact opening temperature	> 85°C
Supply voltage	12 ÷ 24 V
Maximum thermal contact power	3 W

The max. torque is 30 Nm.

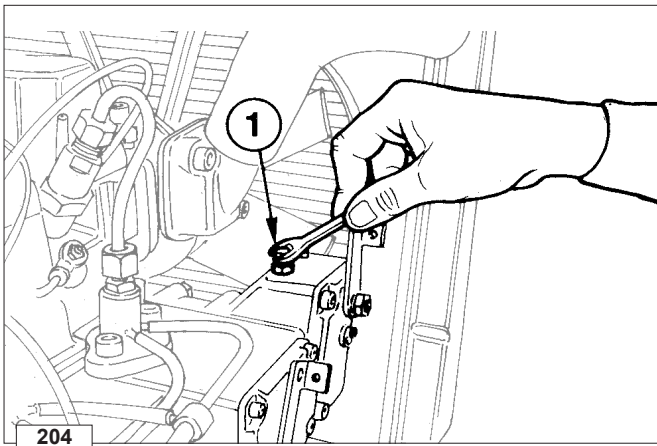

Idling speed setting in no-load conditions (standard)

After filling with oil, fuel and coolant, start the engine and warm up for 10 minutes.
Adjust idling speed at 850÷950 rpm by turning screw 1 then tighten lock nut.

Note: Speed decreases when loosening screw 1 and increases when tightening it.

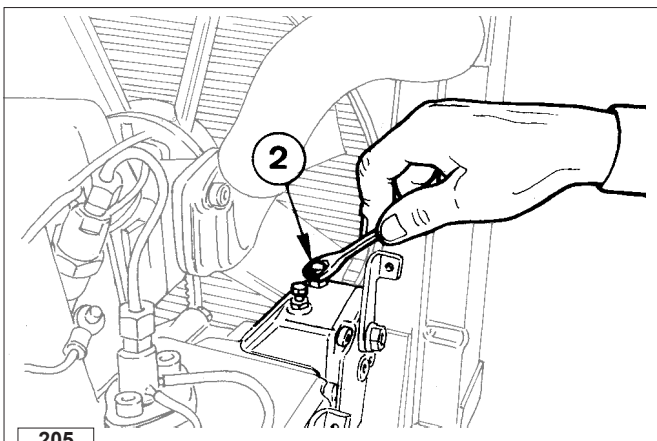

Full speed setting in no-load conditions (standard)

Before carrying out this operation, make sure that the engine adjustment is standard; i.e. corresponding to one of the power curve diagrams shown on pages 20- 21.

Example of adjustment of an engine at 3000 rpm:
After setting idle speed turn screw 2 and set full speed in no-load conditions at 3200 rpm; then tighten lock nut.
When the engine reaches the pre-set power, full speed stabilizes at 3000 rpm.

Nota: Speed increases when loosening screw 2 and decreases when tightening it.

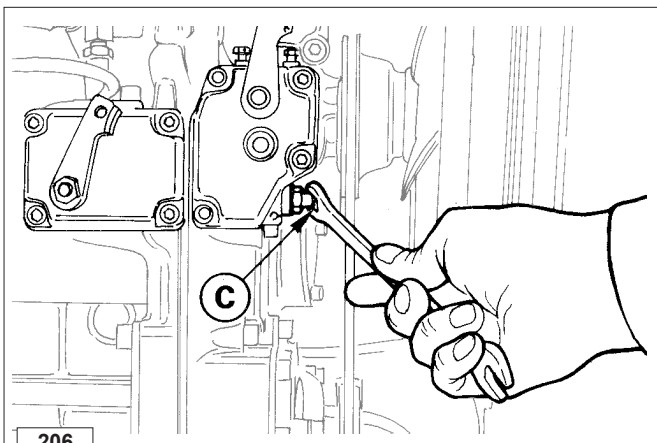

Standard injection pump delivery setting without torque dynamometer

This adjustment must only be carried if necessary and if there is no dynamometric brake, since this type of adjustment is very approximate.

Loosen delivery limiting device C by 5 turns.
Bring engine to max. rpm in no-load conditions i.e. 3200 rpm.
Tighten limiting device C until the engine rpm decreases.
Unscrew limiting device C by 1÷ 1/2 turn.
Tighten lock nut.

Note: If the engine, at full load, generates too much smoke tighten C; loosen C if no smoke is observed at the exhaust and if the engine cannot deliver its full power.

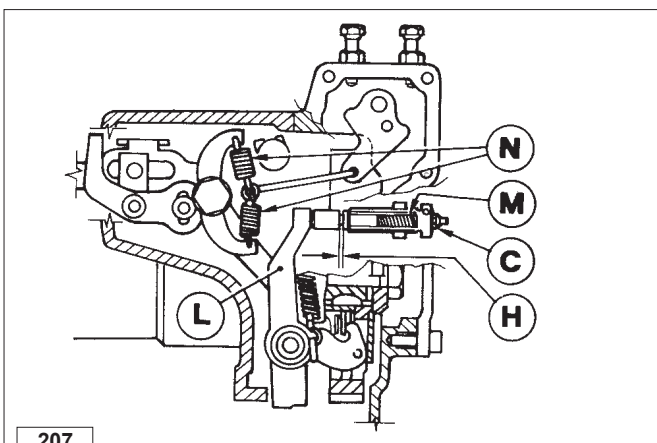

Injection pump delivery limiting and torque adjusting device

Limiting device C has the function of limiting the injection pump maximum delivery
The same device acts as torque adjusting device since springs N act on lever L and thus oppose the resistance of spring M contained in the barrel.
The torque limiting device allows lever L to have a stroke H of 1.0÷1.1 mm: this increases the injection pump delivery while torque reaches its peak.

Note: In application for generating sets and motor welding units the torque adjusting device only acts as delivery limiting device without spring M and stroke H.

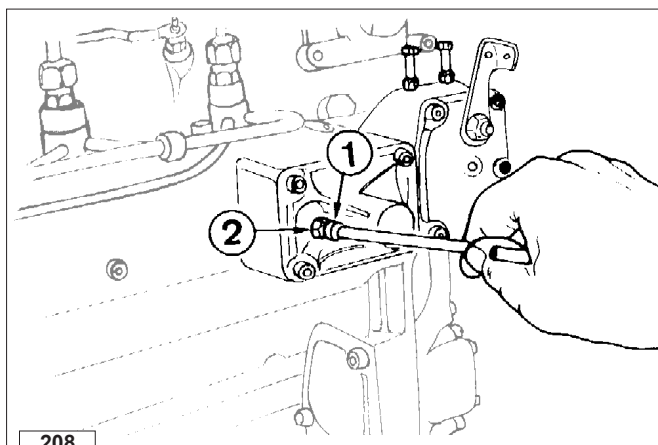

208

Fuel limiting device (fig. 208-209)

When starting up the engine the fuel limiting device has the aim of preventing excessive smoke at the exhaust. Use the delivery adjustment rod of the injection pumps **5** Fig.209 in a constant manner when ambient temperature is above 15°C. As the temperature gradually falls, this device gradually lessens its action to then exclude it at 0°C.

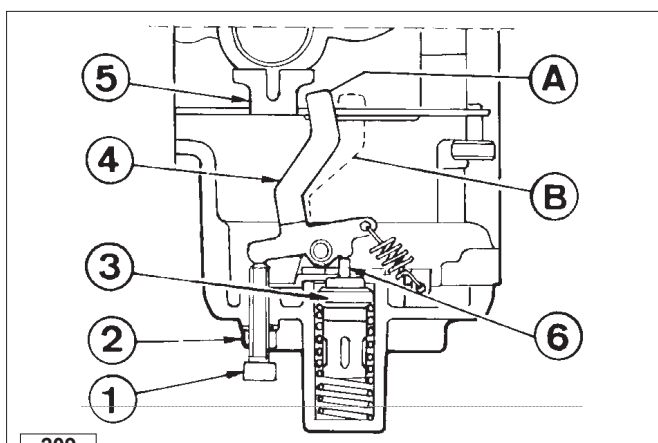

209

Fuel limiting device adjustment (fig208-209)

- Take the engine to the setting speed and power
- Loosen the lock nut **2**.
- Unscrew the screw **1** (to bring lever **4** close up to rod **5**) until the engine speed tends to decrease.
- Screw the screw down by at most 1/2, 3/4 of a turn so as to distance lever **4** from rod **5** by 1.2/1.8 mm. Screw down the lock nut **2**.
- When the temperature falls under 0°C, lever **A** turns (pin **6** of the thermostat **3** comes back in) to go into position **B** thereby allowing rod **5** to go into the supplement position.

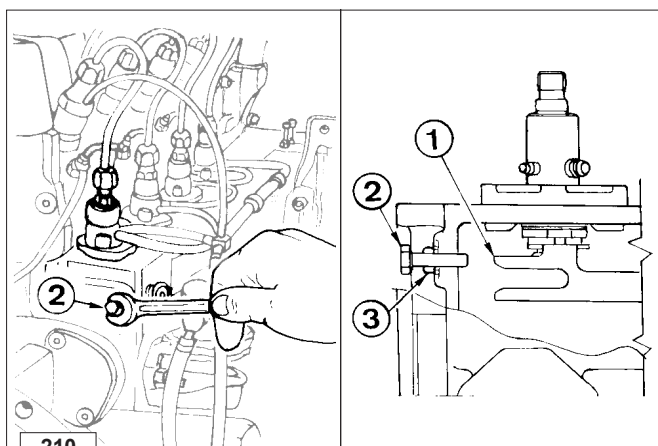

210

Stop setting

- Unscrew the screw **2**
- Move rod **1** fully to the left.
- Screw down screw **2** to touch rod **1**.
- Continue screwing screw **2** by 1/2 turn.
- Lock nut **3**.

Note: In these conditions the injection pump delivery control limit stops cannot be damaged by violent impact caused by operation of any electro-stops that may be fitted.

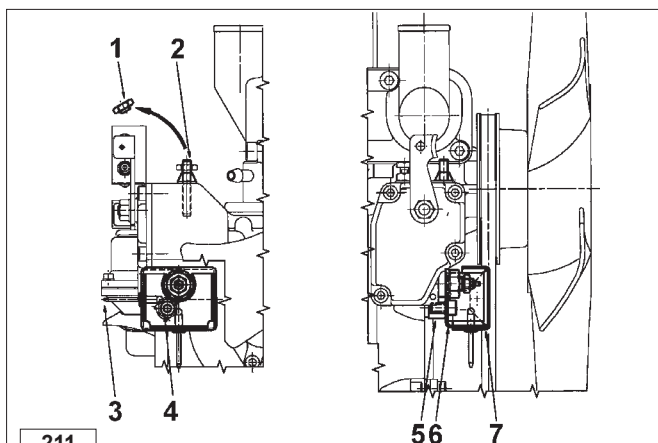

211

Application diagram for tampering system adjustment screw and torque gearing device for EPA-approved engines

Components:

- 1 Breaking nut
- 2 STEI screw
- 3 Rivets (No.2)
- 4 TCEI screw
- 5 Special cover fixing screw
- 6 Lower plate
- 7 Upper plate.

ENGINE STORAGE

- When the engines are not for more than 6 months, they have to be protected performing the operations described in the following pages.
- If the engine is not to be used for extensive periods, check the storage area conditions and the type of packaging and make sure that these are suitable for correct storage.
If necessary, cover the engine with a proper protective sheet.
- Avoid storing the engine in direct contact with the ground, in environments that are humid and exposed to bad weather, near high voltage electric lines, etc.



Important

If, after the first 6 months, the engine is still not used, it is necessary to carry out a further measure to extend the protection period (see "Protective treatment").

PROTECTIVE TREATMENT

- | | |
|--|--|
| <ol style="list-style-type: none"> 1 - Pour in the engine housing AGIP RUSTIA C protective oil up to the maximum level. 2 - Fill up with fuel containing 10% AGIP RUSTIA NT. 3 - Make sure that the coolant is up to the maximum level. 4 - Start the engine and keep it idle at minimum speed for some minutes. 5 - Bring the engine to ¾ of the maximum speed for 5÷10 minutes. 6 - Turn off the engine. 7 - Empty out completely the fuel tank. 8 - Spray SAE 10W on the exhaust and intake manifolds. 9 - Seal the exhaust and intake ducts to prevent foreign bodies from entering. 10 - Thoroughly clean all external parts of the engine using suitable products. | <ol style="list-style-type: none"> 11 - Treat non-painted parts with protective products (AGIP RUSTIA NT). 12 - Loosen the alternator/fan belt. 13 - Cover the engine with a proper protective sheet. |
|--|--|



Caution - Warning

In countries in which AGIP products are not available, find an equivalent product (with specifications: MIL-L-21260C).



Important

Maximum every 24 months of inactivity, the engine must be started up by repeating all "Engine Storage" operations.

PREPARING THE ENGINE FOR OPERATION AFTER PROTECTIVE TREATMENT

After the storage period and before starting up the engine and preparing it for operation, you need to perform certain operations to ensure maximal efficiency conditions.

- | | |
|---|--|
| <ol style="list-style-type: none"> 1 - Remove the protective sheet. 2 - Remove any sealing devices from the exhaust and intake ducts. 3 - Use a cloth soaked in degreasing product to remove the protective treatment from the external parts. 5 - Inject lubricating oil (no more than 2 cm³) into the intake ducts. 6 - Adjust the alternator/fan belt tension. 7 - Turn the engine manually to check the correct movement and smoothness of the mechanical parts. 8 - Refill the tank with fresh fuel. 9 - Make sure that the oil and the coolant are up to the maximum level. 10 - Start the engine and after some minutes bring it to ¾ of the maximum speed for 5-10 minutes. 11 - Turn off the engine. 12 - Remove the oil drain plug (see "Oil replacement") and discharge the AGIP RUSTIA NT protective oil while the engine is hot. 13 - Pour new oil (see "Table of lubricants") up to the maximum level. | <ol style="list-style-type: none"> 14 - Replace the filters (air, oil, fuel) with original spare parts. 15 - Empty the cooling circuit completely and pour in the new coolant up to the maximum level. |
|---|--|



Caution - Warning

Over time, a number of engine components and lubricants lose their properties, so it is important considering whether they need replacing, also based on age (see Replacement table).



Important

Maximum every 24 months of inactivity, the engine must be started up by repeating all "Engine Storage" operations.

MAIN TORQUE SPECIFICATIONS

POSITION	Reference (fig. N° and page)	Ø and pitch mm	Torque Nm	Type of sealant
Alternator fixing bolt	fig. 8 - pag. 29	10x1,5	40	
Diesel fuel union bolts	-	14x1.5	40	
Flywheel housing		10x1.5	50	
Preheating glow plug	fig. 197 - pag. 81	12x1,25	20	
Roker arm cover	fig. 13 + 15 - pag. 30	8x1,25	20	
Main bearing cap		12x1,25	120	
Cap vent		6x1	10	
Intake manifold	fig. 6 - pag. 28	8x1,25	25	
Exhaust manifold	fig. 7 - pag. 28	8x1,25	25	
Throttle cover		6x1	10	
Camshaft cover		6x1	10	
Timing cover	fig. 93 - pag. 48	8x1,25	25	
1P hydraulic pump flange cover		6x1	10	
Hydraulic pump gear support cover		8x1,25	25	
Oil pump top cover		6x1	10	Loctite 270
Oil pump bottom cover		6x1	10	Loctite 518
Thermostat cover		8x1,25	25	
Oil sump		8x1,25	25	
Water pump case and pump support		8x1,25	25	
Flange for flywheel control oil sealing ring		6x1	10	
Nozzle clamping ring nut	fig. 172 - pag. 72	24x2	70 ÷ 90	
Rod support ring nut		18x1,5	40	
Equalizer unit		10x1,5	60	Loctite 242
Oil pressure indicator		12x1,5	35	
Camshaft gear		10x1	100	
Injector	fig. 171 - pag. 72	24x2	70	
Starting motor		10x1,5	45	
Intermediate pin		8x1,25	25	
Front engine foot		16x1,5	200	
Engine foot on bell		10x1,5	40	
Fuel pump		8x1,25	25	Loctite 270
Injection pump	fig. 164 - pag. 69	8x1,25	25	
Feed pump stud bolts		8x1,25	10	
Drive pulley	fig. 10 - pag. 29	16x1,5	360	
Oil filter nipple		UNF 3/4	-	Loctite 270
Fuel pump and solenoid valve union		10x1	12	
Injection pump union	fig. 154 - pag. 68	12x1,5	35	
Intermediate thrust block union		22x1,5	150	Loctite 270
Injection pump union		12x1,5	25	
Water recirculation unions in brass		14x1,5	-	Loctite 554
Revolution counter driving gear		5x0,8	5	
Alternator bracket		8x1,25	25	
Engine mounting bracket		12x1,75	50	
Bracket of the oil suction hose with equalizer		6x1	10	
Bracket of the oil suction hose without equalizer		8x1	25	Loctite 242
Alternator support		8x1,25	25	
Injection pump control rod support		6x1	10	
Rocker arm assembly	fig. 16 - pag. 31	10x1,5	50	Loctite 270
Governor lever support		6x1	10	
Tank bracket		8x1,25	30	
Thermostat support		8x1,25	25	Loctite 242
Crankcase lubrication port plug		14x1,25	-	Loctite 554
Plug for oil pressure regulating valve		16x1,5	50	
Water drain plug		14x1,5	40	Loctite 242
Oil drain plug		18x1,5	50	
Air bleed plug under oil sump		12x1,5	35	Loctite 242
Head	fig.57 ÷ 59 - pag.39-40			
Connecting rod big end	fig. 61, 64 - pag. 40	10x1,5	70	
Oil suction hose		6x1	10	
Air bleed tube under oil sump		12x1,5	35	Loctite 518
Water pump control fan and pulley		6x1	10	
Flywheel	fig. 12 - pag. 30	12x1,25	140	Loctite 270

Table of tightening torques for standard screws (coarse thread)





















Resistance class (R)								
Quality/ Dimensions								
Diameter	R>400N/mm ²		R>500N/mm ²		R>600N/mm ²	R>800N/mm ²	R>1000N/mm ²	R>1200N/mm ²
	Nm	Nm	Nm	Nm	Nm	Nm	Nm	Nm
M3	0,5	0,7	0,6	0,9	1	1,4	1,9	2,3
M4	1,1	1,5	1,4	1,8	2,2	2,9	4,1	4,9
M5	2,3	3	2,8	3,8	4,5	6	8,5	10
M6	3,8	5	4,7	6,3	7,5	10	14	17
M8	9,4	13	12	16	19	25	35	41
M10	18	25	23	31	37	49	69	83
M12	32	43	40	54	65	86	120	145
M14	51	68	63	84	101	135	190	230
M16	79	105	98	131	158	210	295	355
M18	109	145	135	181	218	290	405	485
M20	154	205	193	256	308	410	580	690
M22	206	275	260	344	413	550	780	930
M24	266	355	333	444	533	710	1000	1200
M27	394	525	500	656	788	1050	1500	1800
M30	544	725	680	906	1088	1450	2000	2400

Table of tightening torques for standard screws (fine thread)

Resistance class (R)								
Quality/ Dimensions								
Diameter	R>400N/mm ²		R>500N/mm ²		R>600N/mm ²	R>800N/mm ²	R>1000N/mm ²	R>1200N/mm ²
	Nm	Nm	Nm	Nm	Nm	Nm	Nm	Nm
M 8x1	10	14	13	17	20	27	38	45
M 10x1	21	28	26	35	42	56	79	95
M 10x1,25	20	26	24	33	39	52	73	88
M 12x1,25	36	48	45	59	71	95	135	160
M 12x1,5	38	45	42	56	68	90	125	150
M 14x1,5	56	75	70	94	113	150	210	250
M 16x1,5	84	113	105	141	169	225	315	380
M 18x1,5	122	163	153	203	244	325	460	550
M 18x2	117	157	147	196	235	313	440	530
M 20x1,5	173	230	213	288	345	460	640	770
M 20x2	164	218	204	273	327	436	615	740
M 22x1,5	229	305	287	381	458	610	860	1050
M 24x2	293	390	367	488	585	780	1100	1300
M 27x2	431	575	533	719	863	1150	1600	1950
M 30x2	600	800	750	1000	1200	1600	2250	2700

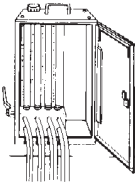
SPECIAL TOOLS	DESCRIPTION	Part No.
	Fuel delivery equalization tool. Allows the adjustment of individual unit injector fuel delivery.	7104-1460-090
	Glass column for fuel delivery equalization tool.	7104-1460-072
	Camshaft bushing replacement tool	7104-1460-021
	Static timing tool	7271-1460-024
	T.D.C. determination fixture.	7107-1460-075
	Pliers for injection pump feeding tubes 1 For tube diam. 6 mm 2 For tube diam. 8 mm	1 7104-1460-022 2 7104-1460-023
	Tool for replacement of injection pump outlet union: 1 For extraction 2 For driving	7107-1460-212

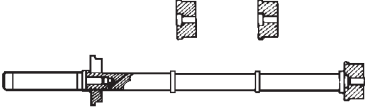
Notes :

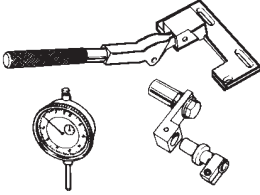
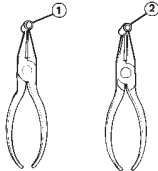
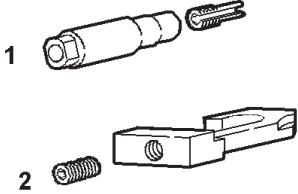
A series of horizontal dotted lines for taking notes.

Translated from the original manual in Italian language.

Data reported in this issue can be modified at any time by KOHLER.

KOHLER®

FOR SALES AND SERVICE INFORMATION
IN U.S. AND CANADA, CALL **1-800-544-2444**

KohlerEngines.com

ENGINE DIVISION, KOHLER CO., KOHLER, WISCONSIN 53044

FORM NO.	ED0053029180		
ISSUED	02/15/2011		
REVISED	00	DATE	02/15/2011